

January 2015

Analytical Report on Consumer Gasoline Choices

Michael Stanley
Cleveland State University

Follow this and additional works at: <https://engagedscholarship.csuohio.edu/tdr>



Part of the [Engineering Commons](#), and the [Physical Sciences and Mathematics Commons](#)

How does access to this work benefit you? Let us know!

Recommended Citation

Stanley, Michael. "Analytical Report on Consumer Gasoline Choices." *The Downtown Review*. Vol. 1. Iss. 1 (2015).

Available at: <https://engagedscholarship.csuohio.edu/tdr/vol1/iss1/2>

This Article is brought to you for free and open access by the Student Scholarship at EngagedScholarship@CSU. It has been accepted for inclusion in The Downtown Review by an authorized editor of EngagedScholarship@CSU. For more information, please contact library.es@csuohio.edu.

Table of Contents

Executive summary	iv
Introduction	v
Part 1: What is Gasoline?	
1.1 Crude oil definition	1
1.2 Extraction, refining, transportation	1
Part 2: How does a vehicle use gasoline?	
2.1 Description of an internal combustion engine	1
2.2 Diesel vs Gas engines and older engines	2
2.3 Potential damage to engines from low grade or improper fuel	3
2.4 Fuel deposits in engine	4
Part 3: What is the best fuel?	
3.1 Octane grade	4
3.2 Knocking and pre-ignition	4
3.3 National standards and laws	5
Part 4: What is the best fuel for my car?	
4.1 Additives	6
4.2 Effect of Ethanol on fuel economy and efficiency	6
4.3 Effect of detergents on fuel economy and engine efficiency	6
4.4 After-market additives	7
Part 5: Which gas brand/retailer has the best fuel?	
5.1 Top Tier Standard	7
5.2 List of top tier brands	8
Part 6: Conclusion	
6.1 Summary and interpretation of findings	9
6.2 Recommendations	9
Works Cited	10

Figures and Tables

Fig. 1. Gasoline Spark Versus Diesel Engine.....	2
Fig. 2. Fuel Deposits	3
Fig. 3. Top Tier gasoline logo.....	8
Table 1. U.S. Top Tier Brands	8

Executive Summary: What is the difference between different brands of gasoline?

Most gas in the United States comes from the same few refineries, where different brands of gasoline are created as they are pumped into the fuel tankers, as opposed to individual retail facilities. Dr. Edward Murphy of the American Petroleum Institute explains that “base gas is a freely traded commodity that must meet certain government specifications. It flows through common pipelines into commingled storage tanks” (Blumberg). Although brands of gasoline have major differences, those differences are not due to origin or refining process, since they are processed from crude oil into gasoline together. The difference in the brands comes late in the process, when additives are combined with the gasoline upon being placed into the fuel tanker trucks, and this is the point when the brands actually become different, “The major brands spend R-and-D money on patented additives, which they add to the basic gas” (Blumberg). The only difference between any brand of gasoline is the additive package that is mixed into the fuel before the tanker trucks even leave the facility.

Since the 1990’s, all brands of gas in the United States are unleaded and have a minimum level of detergents added to fuel as required by federal regulations. Even unbranded gas is treated, albeit less so, “All gasoline has additives. For unbranded gasoline’s, like those sold at low cost outlets, the additive is the generic version that meets minimum federal standards, and the ratio is about a third of a gallon of additive to every 1,000 gallons of gasoline” (Blumberg). Even the generic non-branded gasolines have minimum levels of additives, but many consumers, automotive manufacturers, and gasoline companies feel that the minimum is not sufficient for today’s advanced automobile engines.

Most consumer vehicles are designed to run on Regular unleaded 87 Octane gasoline, and “only about 10 percent of today’s cars need a mid-grade (89 octane) or premium (91 octane or higher) gasoline” (Consumer Reports). Drivers should always check their owner’s manual, but usually regular gas is what commuter vehicles are designed for, and using higher octane gasoline will not

improve performance, fuel economy, or prevent maintenance. According to an article in *The New York Times*, “Generally, the least expensive gasoline available is the best choice, unless your car manufacturer states otherwise” (Richtel). However, using the wrong octane rating, or gasoline blends with lower levels of additives can sometimes cause reduced power, lower gas mileage, and increase fuel deposits on internal parts that damages the vehicle’s engine. When the correct octane rating for a vehicle is known, the only decision left to the consumer is which brand of gas to buy. Top Tier standard gasoline brands are listed at the end of this report that have been independently tested and verified to contain more of the beneficial fuel additives and cleaning detergents that boost engine power, improve fuel economy and prevent engine wear and damage.

Introduction

As consumers have watched gasoline prices more than triple in the last three decades, drivers have become increasingly concerned over how much they pay at the pump. In addition, as more people commute longer distances to work, gas mileage and the wear and tear on their automobile becomes more significant. Fuel economy and reliability are continually improved by new technology as more dependable and efficient engines are designed. Hybrid and electric powered vehicles offer increased gas mileage, but consumers want to know what other variables they can control to improve the performance, longevity, and economy of their vehicle. Many drivers just want to know what the best gasoline is for their regular commuter car.

To understand why fuel type affects vehicle performance, it is important to know how fuel powers modern engines, the effect of fuel additives including fuel detergent, and which octane grades work best for specific engines. This report will provide general answers to these questions and allow consumers to make more informed decisions about what gas they should be buying for their vehicle.

Basic engine operation and fuel chemistry help explain why some gas is better for vehicles than others, and the recommendations section summarizes concepts to help drivers choose the best fuel for their car. Consumers can identify better gasoline for their specific vehicle by narrowing down their choices in three basic fields:

- What type of fuel does the vehicle need?
- What is the recommended octane grade for the vehicle?
- What brands of gasoline are available that have appropriate levels of additives

Part 1: What is Gasoline? Commonly referred to simply as gas, or petrol, gasoline is a mixture of crude oil byproducts and other additives that is used to create a small explosion inside the combustion chamber of vehicle engines.

1.1 Crude Oil Definition

Crude oil is a fossil fuel derived from organic plant and animal matter that has decayed underground for millions of years and formed into dark oil that is highly flammable. The oil that is used today to make fuel and other products comes mainly from areas of the earth that were once covered in dense vegetation and life forms that gradually became swamps and marshes before being covered by erosion and other natural forces. This resource is valuable because of its efficient use as a fuel, but undesirable because of the pollution caused by the by-products of burning the fuel. Crude oil will always grow more expensive due to increasing scarcity and production costs. It takes so long to form naturally that it is not considered renewable; the demand for oil depletes the natural supply much faster than it can be generated.

1.2 Extraction, refining, transportation

Oil is considered “crude” in its unrefined state when it is extracted from underground wells and deposits by drills, derricks, and pumping systems. Raw crude oil is transferred to refinery plants by pipelines that sometimes stretch for thousands of miles, by oil tanker trucks, and also transported by oil vessels overseas to foreign refineries.

At the refining plant, the crude oil is processed to separate petroleum, as well as an array of by-products used to make jet fuel, diesel fuel, asphalt, petroleum jelly, and plastics. The petroleum undergoes various stages of distillation, chemical treatment, emulsification, isomerization and filtering to produce base gasoline. When the base gas is pumped into fuel tanker trucks, additive packages are mixed into the fuel to create different brands of gasoline for sale at retail locations.

Part 2: How does a vehicle use gasoline? The combustive force of exploding gasoline is what powers an engine. Different types of engines have various ways of using the potential energy of combustion, but the principle is the same for gasoline, diesel, and other engines.

2.1 Description of an internal combustion engine

Modern gasoline engines use internal combustion to power the vehicle. There are two types of internal combustion engines commonly in use, diesel and gasoline-spark, which both “use a small explosion in the combustion chamber of a cylinder to power a piston up and down. The piston connects to a crankshaft, which transmits this linear motion into rotary motion to drive the vehicle's wheels” (Ciatti). The kinetic energy that begins as an explosion in the combustion chamber ends with the power sent to the wheels through a series of internal and external moving parts of the automobile.

2.2 Diesel vs Gas engines and older engines

In vehicles manufactured before the 1980s, a type of air intake system known as a carburetor was more common. The introduction of air – separate from fuel – into the combustion chamber relieves knocking and pre-ignition problems. Diesel engines and older carburetor engines also have less problems with fuel deposits on internal parts, since diesel engines compress the air from the carburetor inside the chamber enough to cause combustion, and all of the fuel is expended in each stroke. In gasoline spark engines, a gas and fuel mixture is injected into the chamber which is partially compressed and a spark ignites most of the fuel, but some residual fuel remains in the chamber and the injector and valves can become clogged with deposits.

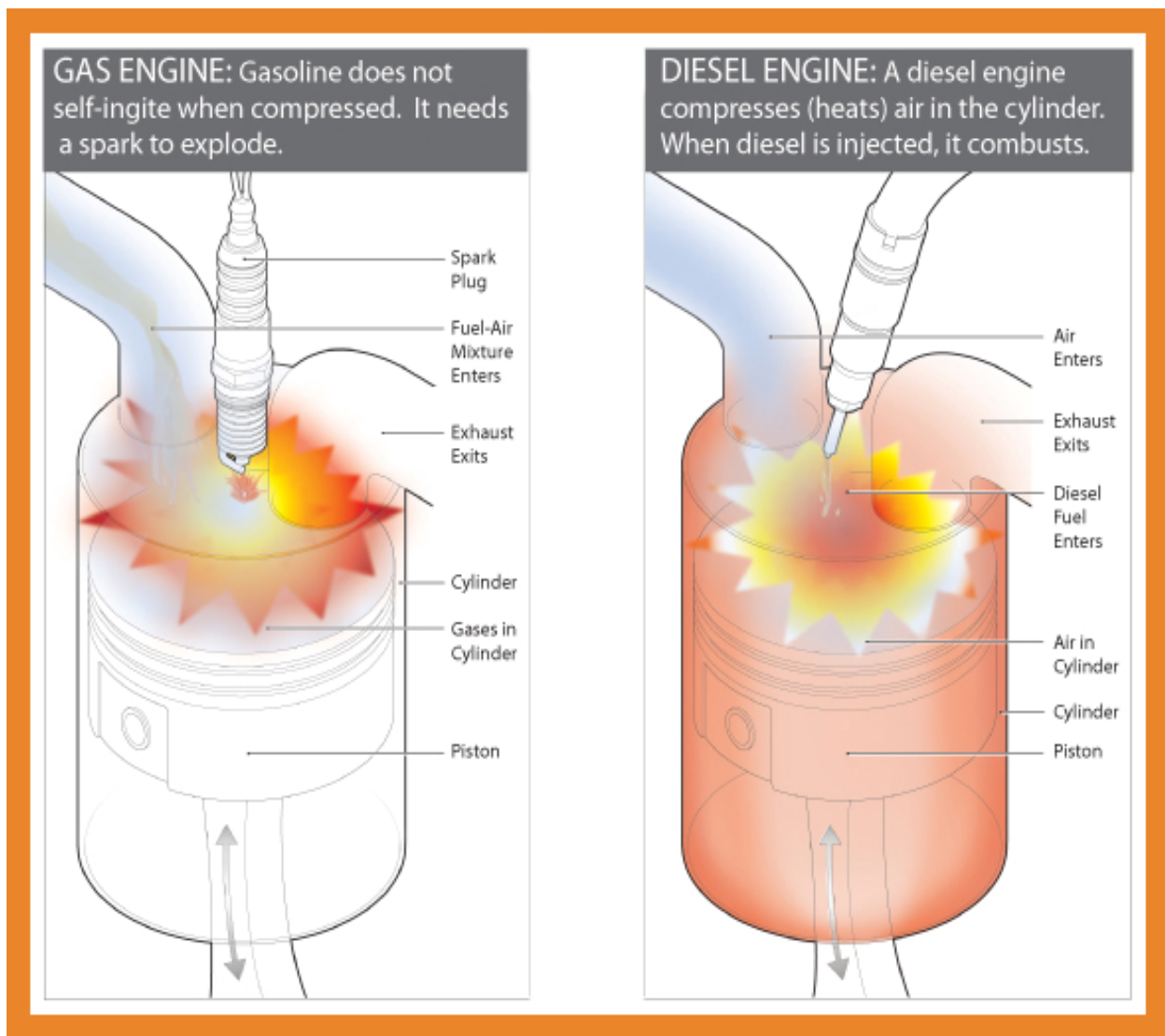

Figure 2 – Gasoline-Spark versus Diesel Engine Source: <http://ezibaco.vacau.com/gasoline-engines-vs-diesel-engines.php>

However, recent EPA regulations and the more sophisticated engines in use today require the use of gasoline-spark engines with a pre-mixed fuel and air gas that is injected into the combustion chamber, which can cause build-up of fuel deposits. This presented engineers with many problems, though “by the mid-1980s, the oil industry had developed special detergents to solve that problem. But a new problem arose: Cars built since 1985 proved especially sensitive to the deposits that form on an engine's intake valves” (Consumer Reports). Most cars on the roads today require cleaner-burning fuels with detergents that actively clean and protect internal engine parts to prevent loss of power and damage to the engine.

2.3 Potential damage to engines from low-grade or improper fuel

The remnants of fuel left inside the combustion chamber and inside the intake valve from the fuel can build up and cause loss of power, lower fuel economy, and can damage the internal parts. Because modern gasoline-spark engines mix the fuel and air prior to ignition, fuel injectors and valves need to be cleaned to operate properly, as “Fuel-injection systems are more sensitive to clogging from fuel deposits than carburetors are. They need a gasoline with detergents that will keep the injectors unclogged” (Consumer Reports). The engines built for automobiles today are designed to use the newer fuels with regulated amounts of additives and detergents and have been required by law.

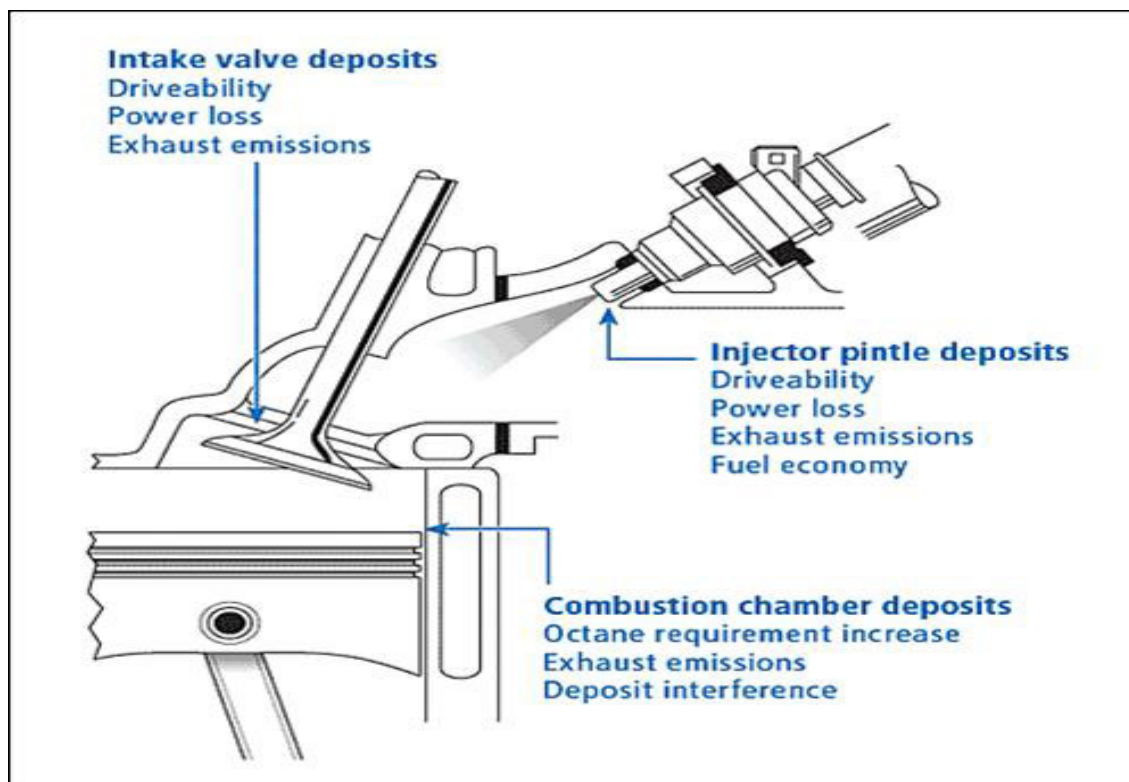

Figure 2 – Fuel deposits Source: <http://www.ardinarcare.com/carcare-fuel-system.html>

2.4 Fuel deposits in engines

It is normal for fuel deposits to occur with all grades of fuel regardless of octane rating. All fuels require detergents for removal since “these deposits are formed of various compounds, among them olefins and di-olefins with double bonds that break down and form gummy deposits that can alter airflow around intake valves or fuel flow from injectors” (Consumer Reports). In addition, Shell fuels technology manager Jim Macias has noted that “these carbonaceous deposits start out as one of the 300 compounds in gasoline, then polymerize on hot surfaces. There's no single component to target, which complicates preventing or cleaning them” (Consumer Reports).

The best solution is to use detergent fuel that cleans all the surfaces that would otherwise become clogged or form deposits as the fuel is being used, this way no build-up of carbon deposits can occur and the engine remains functional.

Part 3: What is the best fuel? There is no single best fuel for all makes and models of vehicles. However, there are differences in octane ratings related to the compression ratio of a vehicle's combustion chamber. Knowing the proper octane rating for a specific vehicle helps narrow down the choices of potential fuels.

3.1 Octane grade, knocking, and pre-ignition

One common misconception is that higher octane grades of gasoline are better for a vehicle. The best octane gas to use is the one that the owner's manual recommends. Octane is added to fuel to reduce heptane levels, which raises the temperature necessary for ignition and reduces knocking: “The higher a gasoline's octane, the more compression it can withstand. Performance cars generally require high-octane premium gasoline for their high-compression engines” (Ciatti). If a vehicle has a high performance engine, it may require a higher octane rating, but owner's manuals can also provide information about the appropriate octane rating of gasoline for a particular vehicle.

3.2 Knocking and pre-ignition

Knocking and pre-ignition occur when the fuel and air mixture ignites before or after the piston is fully compresses in the combustion chamber and throws off the timing of the engine. This reduces both engine power and fuel efficiency, and damages the internal parts of the engine.

There are three common octane grades of gasoline available in the United States:

- *Regular* - Octane rating of 87
- *Medium* - Octane rating of 89
- *Premium* - Octane rating of 93

If the vehicle is designed to operate on regular octane gas, putting a higher octane fuel into the system will reduce power. The size and shape of the combustion chamber determine the compression ratio, a measurement of the force created when the piston compresses the gas in the chamber. If the compression ratio is not high enough to ignite the gas effectively at the top of the stroke, the engine loses power and fuel efficiency.

A common example can be found in racecar fuel, which often has a grade of over 100 since “Some performance vehicles have combustion chambers with very high compression ratios and benefit from high octane fuel that ignites at a greater pressure and temperature” (Blumberg). The higher grade does not make racecar fuel objectively better, and the number instead shows how it requires more oxygen and power from the pistons to ignite the fuel, creating a larger explosion and more power.

If the compression ratio of the combustion chamber in a vehicle is not sufficient to ignite the racecar fuel, power will be wasted trying to run the engine on higher octane level gasoline, and knocking can occur from the residual fuel in the chamber that was not ignited.

3.3 National standards and laws

Even with the proper grade octane, fuel deposits will still build up in a vehicle engine without detergents. In 1995, government regulation passed mandating a minimum requirement for detergents in all gasoline, but minimums have since fallen “by an estimated 50 percent” (Laracy). To meet this, many retailers of gas brands continue to lower detergents in their additive packages, and “As a result, the ability of vehicles to maintain stringent Tier 2 emission standards has been hampered, leading to engine deposits that can have a big impact on in-use emissions and customer satisfactions” (Laracy). Even though the government regulates the minimum additives required in all fuel sold domestically, a particular brand of gasoline may use just enough to meet the minimum, well below the recommended levels.

Some car manufacturers became concerned that minimum detergent levels recommended by the EPA were insufficient for proper vehicle operation. Rather than lowering their detergent levels, some fuel companies have raised additive and detergent levels to meet manufacturers recommendations and growing consumer demand, “After unsuccessfully lobbying for higher standards, a group of automakers (Audi, BMW GM, Honda, Mercedes, Toyota, and Volkswagen) consulted with fuel suppliers to establish a higher voluntary standard, marketed as Top Tier Detergent Gasoline” (Markus). Some of the most recognized auto-makers unanimously support and recommend using Top Tier fuel for use in their own vehicles.

Part 4: What is the best fuel? Choosing the best fuel depends on the specific make and model of the vehicle as much as using a gasoline with an amount of additives that will clean internal parts of the engine preventing damage and increasing fuel economy. The best fuel for a particular vehicle is the one that has the octane rating recommended for its engine as well as satisfactory levels of additives that boost fuel economy and keep internal engine parts clean.

4.1 Additives

Many different types of chemicals are added to gasoline to boost fuel efficiency and help clean engines. The formulas of each brand's additive are proprietary and not available to the public, but the effects of the additions are pronounced: "The majority of them are dedicated to the improvement of the processes of fuel combustion and thereby promotes a toxicity decrease of the combustion products" (Tsarev 563). It is not important for consumer to know the chemistry behind what makes fuel more efficient, so much as knowing that their brand of gasoline uses enough additive to promote efficiency and effectively clean engine parts.

Different brands of gasoline use widely varied amounts of additive in their fuel packages. Some brands of gasoline use the minimum required additives and detergents, while "Shell V-Power has more than five times the minimum amount of cleaning agents required by government standards" (Laracy). Choosing a Top Tier brand fuel guarantees that additive and detergent levels are at least as high as automotive manufacturers agree is appropriate, often much higher than is required by the government.

4.2 Effect of ethanol on fuel economy and efficiency

Other combustible products are sometimes combined with gasoline to boost the octane level. Ethanol is a corn-based alcohol that serves as a good fuel additive, since "Alcohol – gasoline blends have engine properties comparable to traditional petroleum fuels. Despite the lower heat of combustion, these compounds ensure operation on lean blends" (Raskazchikova 205). Blending ethanol with gasoline lower the cost of fuel for both the gasoline company and the consumer, and also burns cleaner than pure gasoline.

Ethanol is more combustible, but it also raises octane levels, thus eliminating the risk of knocking or pre-ignition below a 10% concentration. Federal regulations prevent gasoline suppliers from diluting their gasoline blends with alcohol beyond this level, and engines are not harmed by the use of ethanol in the fuel. (Raskazchikova 207). All Top Tier brand fuels blend ethanol with gasoline in a ratio that ensures maximum efficiency without damaging the engine parts.

4.3 Effect of detergents on fuel economy and efficiency

Detergents keep the engine clean and running smoothly. Older vehicles could operate on leaded gasoline because it used carburetors. Modern gas-spark engines that pre-mix fuel with air and more sophisticated engine mechanics require regular cleaning to keep parts functioning properly:

Refiners have been adding detergents to their gasoline at least since the 1950s to keep carburetors clean. Those detergents sufficed until the early 1980s, when fuel-injected engines began to appear in more and more cars. Owners of late models began to complain of poor performance. The fuel injectors' orifices, some as narrow as a hair, were being clogged with deposits. (Consumer Reports)

Some gasoline brands have recognized the need for higher detergent and additive levels and provide customers with specialized gasoline blends, as when "Shell Oil Products U.S. also

recently develop[ed] its new advanced fuel, V-Power, which actively cleans critical engine parts – specifically intake valves and fuel injectors – as customers drive their cars” (Laracy). Other Top Tier brands have similar proprietary blends, but all effectively clean engine parts.

4.4 After-market additives

Some consumers choose to purchase their own additive products to add to their fuel tanks. The formulas of these additives are similar to some gas brand additive blends, but the exact formulas are secret and proprietary just like brand additive packages, and mixing additive to fuel by pouring directly into the fuel tank is less precise, “As for fuel-system cleaning products, the aftermarket treatments tend to be high concentrations of these additives. Some of that material can get into the crankcase, and the effects are not entirely known” (Markus). Putting additives into the vehicles gas tank can never be as exact as the mixing procedures done at the refinery, nor can the consumer know exactly what levels of which additives are already in the fuel, so after-market additives are an unnecessary risk that may have detrimental rather than positive effects.

Part 5: Which Gas brand/retailer has the best fuel? Once the consumer has determined what octane level of fuel is appropriate for their vehicle, the remaining choice is where to get a gasoline with higher levels of detergents and additives.

5.1 Top Tier Standard

In 2004, several automobile manufacturers responded to the dropping levels of detergent additive found in gasoline brands by creating a new standard called Top Tier gasoline, “Seven of the world’s top automakers, BMW, General Motors, Honda, Toyota, Volkswagen, Mercedes-Benz and Audi recognize that the current EPA minimum detergent requirements do not go far enough to ensure optimal engine performance” (Toptiergas.com). These companies recommend the high-additive fuels to ensure their own vehicles perform better.

Minimum levels of detergent and additives are much higher for the Top Tier standard, and designed to increase fuel economy and decrease wear on engine parts. (Markus) In addition to increasing detergent levels, Top Tier designation also requires higher ethanol levels while remaining in a safe range for engine operation, this prevents gasoline retailers from diluting their product with alcohols to cut fuel production costs, Top Tier fuel must “contain enough denatured ethanol such that the actual ethanol content is no less than 8.0 and no more than 10.0 volume percent” (Toptiergas.com). This prevents gasoline providers from thinning out fuels to save money while providing the most efficient and clean-burning fuels.



Figure 3: Top Tier gasoline logo Source: <http://www.autoguide.com>

All gasoline retailers can apply for Top Tier status, “Once a fuel marketer has submitted their performance testing results, the data is reviewed by all of the automotive sponsors against the performance specification limits and is either a Pass or a Fail. If a Pass, the fuel marketer will be given a TOP TIER license agreement” (Toptiergas.com). Several gasoline brands advertise their special additive packages as an effective method of boosting vehicle power and efficiency while cleanings and maintaining engine parts:

5.2 List of Top Tier Brands

Table 1: U.S. Top Tier Brands

76 Stations		Conoco		BP		
ARCO		Aloha Petroleum		CountryMark		
Entec Stations		Exxon		Holiday Stationstores		
Ohana Fuels		Phillips 66		Kwik Trip / Kwik Star		
Tri-Par Oil Co.		Shell		SuperAmerica		
Quik Trip		Scheirl Oil		Road Ranger		
Chevron		Mobil		Hawaii Fueling Network		
MFA Oil Co.		Texaco		Costco Wholesale		
Express Convenience Centers						

Part 6: Conclusion

6.1 Summary and Interpretation of Findings

The major differences found in gasoline are the octane grade and the additives packages that gasoline retailers include in their fuel to create specific brands. Choosing the best gasoline for a vehicle first involves consulting the dealer or owner's manual to determine what octane rating is appropriate for the vehicle. The second part of choosing the best gasoline involves using a brand of gas with higher levels of beneficial additives and detergents. In 1995, the federal government passed legislation that requires all gasoline brands to maintain minimum levels of additives like ethanol and detergents that help clean and protect the engine from wear and improve fuel economy. In 2004, eight automakers created a new standard for gasoline additives that includes increased levels of detergents. Gasoline retailers that have been certified to meet these minimums and supply all their retail locations with the higher standard fuel can apply for the label of Top Tier gasoline.

6.2 Recommendations

Choosing the right gasoline for a particular vehicle is one of the few options drivers have that can significantly improve or hinder the overall performance of their vehicle, as well as one of the most important choices for preventative maintenance. Continued use of low detergent fuel can cause lower fuel economy, loss of power, and fuel deposit buildup in engine parts with the potential for damage to the internal engine parts.

Consumers that want the best fuel should know the octane rating of their vehicle and always use that grade of fuel. To prevent harmful fuel deposit buildup, increase gas mileage, and boost engine power, consumers should use gas from a Top Tier gasoline retailer regularly to be sure the fuel they put in their gas tank meets minimum additive and detergent levels recommended by several automobile manufactures, and to maximize the benefits of clean burning efficient fuel.

Works Cited

Top Tier Gasoline. Top Tier Gasoline, n.d. Web. 30 July 2014.

<http://www.toptiergas.com/index.html>.

Blumberg, George P. "My Gasoline Beats Yours (Doesn't it?)." *New York Times*: F.1. Nov 22, 2002. Web.

Ciatti, Steve. "The Gasoline Diesel." *Mechanical Engineering* 134.9 (2012): 38-41. Print.

Laracy, Alex. *Raising the Bar on Gasoline Standards: ChevronTexaco, QuikTrip Get 'Top Tier' Gas Nod*. Stagnito Media, 2004. Web.

Markus, Frank. "All Fuels are Not Created Equal." *Motor Trend* 66.5 (2014): 36-. Print.

Raskazchikova, T. V., V. M. Kapustin, and S. A. Karpov. "Ethanol as High-Octane Additive to Automotive Gasolines. Production and use in Russia and Abroad." *Chemistry & Technology of Fuels & Oils* 40.4 (2004): 203-10. Web.

Richtel, Matt. "With so Many Gasoline Choices, what's a Driver to do?" *New York Times (1923-Current file)*: BU7. Jul 11, 2004. Web.

Tsarev, A. V., and S. A. Karpov. "Increase of the Environmental and Operational Characteristics of Automobile Gasolines with the Introduction of Oxygenates." *Theoretical Foundations of Chemical Engineering* 43.4 (2009): 563-7. Web.

"Which Gasoline for Your Car?" *Consumer Reports* January 1990: 8. Web.