

ETD Archive

2010

Application of Multiple Intelligence Theory to an E-Learning Technology Acceptance Model

Alfred J. Degennaro
Cleveland State University

Follow this and additional works at: <https://engagedscholarship.csuohio.edu/etdarchive>



Part of the [Business Commons](#)

[How does access to this work benefit you? Let us know!](#)

Recommended Citation

Degennaro, Alfred J., "Application of Multiple Intelligence Theory to an E-Learning Technology Acceptance Model" (2010). *ETD Archive*. 77.

<https://engagedscholarship.csuohio.edu/etdarchive/77>

This Dissertation is brought to you for free and open access by EngagedScholarship@CSU. It has been accepted for inclusion in ETD Archive by an authorized administrator of EngagedScholarship@CSU. For more information, please contact library.es@csuohio.edu.

APPLICATION OF MULTIPLE INTELLIGENCE THEORY TO AN ELEARNING
TECHNOLOGY ACCEPTANCE MODEL

ALFRED J. DEGENNARO

Bachelor of Arts in Mathematics & Philosophy

Cleveland State University

December, 1981

Master of Arts in Mathematics

Cleveland State University

December, 1986

Master of Arts in Computer and Information Systems

Cleveland State University

June, 1987

submitted in partial fulfillment of requirement for the degree

DOCTOR OF BUSINESS ADMINISTRATION IN INFORMATION SYSTEMS

at the

CLEVELAND STATE UNIVERSITY

MAY, 2010

This dissertation has been approved
for the Department of INFORMATION SCIENCES
and the College of Graduate Studies by

Dissertation Chairperson, Dr. Santosh Misra

Department & Date

Dr. Victor Matos

Department & Date

Dr. Sridhar Madhavaram

Department & Date

Dr. Susan Rakow

Department & Date

In loving memory of my grandfather, who saw the potential in me and planted the seed.

I take pause to acknowledge that none of this could have been accomplished without the support of my family and the prayers of my mother and father. I am especially thankful for my wife, Sarah, who provided the opportunity and motivation to bring this work to closure. I extend this gratitude to my committee and especially Dr. Santosh Misra and his infinite patience.

APPLICATION OF MULTIPLE INTELLIGENCE THEORY TO AN ELEARNING TECHNOLOGY ACCEPTANCE MODEL

ALFRED J. DEGENNARO

ABSTRACT

With the speed of doing business on the rise, employees must learn to adapt to new technologies and improved performance expectations without losing productivity or time on task. Students looking to enter the workforce must understand that education does not end with graduation; rather the expectation is that everyone will be life long learners.

To meet the challenge, education providers are looking for alternative ways to bring education to the student and enhance the learning experience. With e-learning, students enjoy flexible scheduling, businesses can realize improvements in workforce skills while reducing education expenditures (i.e. improved Return On Investment, ROI) and education providers extend their campuses at minimal cost. E-learning is fast becoming a preferred method of delivering quality education any time, any where.

Educators, however, have mixed feelings on the subject. Many have embraced the new technology and report positive results. Others question the effectiveness of e-learning, pointing to the high dropout rate in e-learning courses and bias in the literature supporting e-learning. The cautious are concerned about rushing in on uncertain ground. They recall the advent of television and the unmet promises of that technology with respect to education.

The purpose of this study is to develop an e-learning adoption model that is firmly founded in education research (especially with respect to learning) coupled with what is understood about the diffusion and acceptance of (information) technology. The goal of developing such a model is to identify and pair crucial learning characteristics

of students with the acceptance of the technology used to deliver educational content electronically so as to foster mastery learning. Students can use the results of this study to help decide whether or not to enroll in an e-learning course or what additional strategies they may need to employ so as to maximize the experience. Businesses may benefit from an understanding of how to match the needs of their employees with appropriate criteria for selecting the most effective e-learning delivery system. Schools and colleges can use such a model to help minimize the dropout rate from distance learning courses and to promote overall student success.

TABLE OF CONTENTS

	Page
ABSTRACT	v
LIST OF TABLES	xi
LIST OF FIGURES	xiv
CHAPTER	
I INTRODUCTION	1
1.1 Trends in Distance Learning	4
1.1.1 Technology	4
1.1.2 Enrollment	5
1.1.3 Faculty	7
1.1.4 Academic	9
1.1.5 Business	11
1.2 Controversy	12
1.3 The Purpose of this Study	18
1.4 Contributions of Research	20
1.5 Summary	21
II LITERATURE REVIEW	22
2.1 Content	25
2.2 Instructor/Delivery Agent	29
2.3 Environment	31
2.4 Student	34
2.4.1 Acceptance Models	35
2.4.2 External Variables Related to e-Learning; An Extended Edu- cational TAM	38
2.4.2.1 Self Efficacy	39
2.4.2.2 Computer Experience	41

Chapter	Page
2.4.2.3 Social Influence Processes	42
2.4.2.4 Culture	45
2.4.2.5 Gender	46
2.4.2.6 Learning Style and Multiple Intelligences	47
2.4.2.7 Intrinsic Motivations	50
2.4.2.8 Extrinsic Motivations	51
2.4.2.9 Acceptance	51
2.4.3 Summary	54
2.5 Assessment	55
2.6 Feedback	58
2.7 Summary	59
III METHODOLOGY	63
3.1 Research Question	63
3.2 Hypotheses	64
3.3 Research Design	76
3.3.1 Sample	76
3.3.2 Survey Instruments	78
3.3.2.1 TAM Survey	78
3.3.2.2 Multiple Intelligences Developmental Assessment Scales	79
3.3.3 Data Collection	80
3.3.4 Data Analysis Methods	83
3.3.4.1 Regression Assumptions	85
3.3.4.2 Linear Relationship	89
3.3.4.3 Outliers	90
3.3.4.4 Test for Homogeneity of Variance	91
3.3.4.5 Criteria for Selecting Between Competing Models	92

Chapter	Page
IV FINDINGS AND DISCUSSION	94
4.1 Analysis of Findings	102
4.1.1 Technology Acceptance Model	102
4.1.1.1 Relationship between Perceived Usefulness and Per- ceived Ease of Use (PU ~ PEU)	112
4.1.1.2 Relationship between Attitude Toward Using and Per- ceived Usefulness and Perceived Ease of Use (ATU ~ PU + PEU)	122
4.1.1.3 Relationship between Behavioral Intention to Use and Attitude Toward Using (BIU ~ ATU)	134
4.1.2 Multiple Intelligences Developmental Assessment Scales (MI- DAS)	143
4.1.3 Relationship between the Technology Acceptance Model and Multiple Intelligences (TAM ~ MIDAS)	148
4.2 Discussion	158
V CONCLUSIONS AND RECOMMENDATIONS	159
BIBLIOGRAPHY	164
APPENDICES	188
A Compiled Timeline	189
B Bloom’s Taxonomy	192
C elearning Tools	194
D Factors from the Literature	203
E Generations of Distance Learning	207
F Learning Concepts and Domains	211
G Learning Theories	214
H MIDAS Profile	218

Appendix	Page
I TAM Survey	222
J Gender and Ethnicity	226
K TAMFACTORS & MIDAS Subscales	228

LIST OF TABLES

Table	Page
1.1 Modes of (Distance) Learning	3
1.2 Expanding Distance Education	8
1.3 Shortcomings of Distance Learning Research, taken from "What's the Difference?" [137]	16
1.4 Distance Education Participation	17
2.1 Wiley's Taxonomy of Learning Object Types	26
2.2 A Practitioner's Criteria	28
3.1 Neurological Systems vis-a-vie MI	67
3.2 Multiple Intelligences in Everyday Life[163]	70
3.3 Classes Surveyed	82
3.4 Demographic: Gender Composition [142]	83
3.5 Demographic: Racial Composition [142]	83
3.6 Demographic: Grade Level Composition [142]	84
3.7 Previous Experience with eLearning [190]	84
3.8 Consequences of Heteroskedasticity	88
3.9 Information Criteria Used for Model Selection	93
4.1 Hypotheses Outcomes	94
4.1 Hypotheses Outcomes	95
4.1 Hypotheses Outcomes	96
4.1 Hypotheses Outcomes	97
4.2 Uses of Computer Technology: Descriptive Statistics [35, 142]	101
4.8 Technology Acceptance Model Survey: Internal Reliability [144]	102
4.3 Technology Acceptance Model Factor: Perceived Usefulness (Part 1)[190]	103
4.4 Technology Acceptance Model Factor: Perceived Usefulness (Part 2)[190]	104
4.5 Technology Acceptance Model Factor: Perceived Ease of Use [190]	108

Table	Page
4.6 Technology Acceptance Model Factor: Behavioral Intention to Use [190] . . .	109
4.7 Technology Acceptance Model Factor: Attitude Toward Using [190]	109
4.9 TAM <i>Factor</i> Mean Summary Statistics [33]	110
4.10 Tests for Normality of the TAM <i>Factor</i> Means [33]	111
4.11 Pearson Correlation: PEUmean & PUmean	112
4.12 PU~PEU: Leverage	115
4.13 Regression Model: PU ~ PEU [33]	116
4.14 PU~PEU: Test for Nonlinearity	118
4.15 PU~PEU: Heteroskedasticity	119
4.16 PU~PEU: Normality of Residuals	119
4.17 Pearson Correlation: ATU & PU, ATU & PEU	122
4.18 ATU~PEU+PU	124
4.19 ATU~PEU+PU: Influential Values	126
4.20 ATU~PEU+PU	129
4.21 ATU~PEU+PU: linearity	129
4.22 ATU~PEU+PU: Heteroskedasticity	130
4.23 ATU~PEU+PU: Corrected Model	130
4.24 ATU~PEU+PU: Multicollinearity [33]	131
4.25 ATU~PEU+PU: Confidence Intervals	134
4.26 Pearson Correlation: ATU & BIU	134
4.27 BIU~ATU	136
4.28 Leverage for BIU~ATU [33]	138
4.29 BIU~ATU: Confidence Intervals	138
4.30 BIU~ATU: t-test zero mean for residuals	140
4.31 Ramsey's RESET for BIU~ATU [33]	140
4.32 BIU~ATU: Homoskedasticity of Residuals	141

Table	Page
4.33 MIDAS Score Categories [163]	144
4.34 MIDAS Reliabilities	144
4.35 MIDAS: Boxplot Summary	146
4.36 Summary Stats for MIDAS	148
4.37 Quantile-Quantile Plot Diagnostics	150
4.38 PEU~MIDAS: Regression	154
4.39 PEU~MIDAS: Confidence Intervals	155
4.40 PEU~MIDAS: Multicollinearity	155
4.41 PU~MIDAS: Regression	156
4.42 PU~MIDAS: Confidence Intervals	157
4.43 PU~MIDAS: Variance Influence Factors	157
4.1 TAM Factors	203
4.2 TAM Factors (continued)	204
4.3 Education Factors	205
4.4 Education Factors (continued)	206
6.1 Learning Domains	212
6.3 Learning Concepts	213

LIST OF FIGURES

Figure	Page
1.1 The "T" Employee	2
1.2 Bachelor Degrees Conferred Projected Through 2012, by Gender	6
1.3 Distance Education Offerings and Enrollment	6
1.4 A QQPlot of Distance Learning Students with a Strong Response	18
2.1 A Simplified Model of Learning Systems	24
2.2 Merrill's Phases for Effective Instruction	31
2.3 Theory of Reasoned Actions (TRA)	36
2.4 Technology Acceptance Model	37
2.5 TAM Tested Factors	39
2.6 Learning Styles	49
2.7 Daley on DOL in e-learning	53
2.8 Effective e-learning	62
3.1 Multiple Intelligences vis-a-vis TAM	65
3.2 Hypotheses of the MI Extended TAM	73
4.1 MI Extended TAM Model	98
4.2 Student Uses of Computer Technology [144]	100
4.3 TAM <i>Factor</i> Mean Histograms [33]	106
4.4 Technology Acceptance Model: Data Plots and Correlations Between Factor Means [144]	107
4.5 Regression Lines Plotted [33]	114
4.6 PU~PEU: Residuals of Predicted Values	117
4.7 PU~PEU: Residuals Test for Normality	120
4.8 PU~PEU: Influence	121
4.9 ATU~PEU+PU: Plot Actual versus Fitted ATUmean	125
4.10 ATU~PEU+PU: Residuals	128

Figure	Page
4.11 ATU~PEU+PU: Normality of Residuals	132
4.12 ATU~PEU+PU: Influence	133
4.13 BIU~ATU: Regression Line Plots	137
4.14 BIU~ATU: Residuals	139
4.15 BIU~ATU: Test for Normality of Residuals	142
4.16 BIU~ATU: Influence Points	142
4.17 MIDAS Intelligences Boxplots	145
4.18 Normal Plots of MIDAS Multiple Intelligences	147
4.19 MIDAS Intelligences Histograms	149
4.20 TAM Factors versus MIDAS Intelligences	152
5.1 Revised Learning Systems Model	161
8.1 Sample MIDAS Profile Page 1	219
8.2 MIDAS Profile Page 2	220
8.3 MIDAS Profile Page 3	221
9.1 TAM Survey Page 1	223
9.2 TAM Survey Page 2	224
9.3 TAM Survey Page 3	225
10.1 Coplots: MIDAS PEUmean/PUmean by Gender by Ethnicity	227
11.1 TAM Correlated to MIDAS Musical Subscales	229
11.2 TAM Correlated to MIDAS Logic/Mathematical Subscales	230
11.3 TAM Correlated to MIDAS Kinesthetic Subscales	231
11.4 TAM Correlated to MIDAS Linguistic Subscales	232
11.5 TAM Correlated to MIDAS Spatial Subscales	233
11.6 TAM Correlated to MIDAS Interpersonal Subscales	234
11.7 TAM Correlated to MIDAS Intrapersonal Subscales	235
11.8 TAM Correlated to MIDAS Nature Subscales	236

CHAPTER I

INTRODUCTION

Think about sending your child to school or attending college yourself. What you probably envision is a traditional face-to-face classroom where students sit at desks with the teacher at the front doling out an education. Whether in a public, private, or parochial school, or through tutelage, internships, or apprenticeship, it is the traditional face-to-face methods that are commonly perceived as the best method of delivering instruction.

Now, visit again the image you conjured about school. Consider the means of delivering instruction. Was it hands on? Did it involve hours of drill and recitation? Was it project or lab based? Were groups of students collaborating? Was the instructor the "Keeper of Knowledge" or was knowledge gained by discovery with the instructor serving as guide? The process of delivering a quality education that will engage all students is messy and difficult to quantify. Many camps exist within educational pedagogy, each with its own view of how to deliver quality instruction with the greatest impact. Of course education is not an exact science, for if it were, one would apply that formula with 100% success and all students would succeed equally well and with complete subject mastery.

Theories of teaching and learning are dynamic, rife with change. Educators and educational institutions are constantly redefining themselves as new theories are purported and new techniques developed. Aligning themselves with modern methods, educators seek to attract students and to address the increasing pressure for improved performance that is

being demanded of both student and educator by government¹, business, and community.

There is a crisis in American education. This is not news. Dollars are short, students are performing below expectations, businesses are screaming that the workforce is ill prepared for employment². Some suggest that unless there is a dramatic turn of events the United States of America will soon lose its position of super power. Education reform is on everyone's lips.[6, 188]

Confounding the problem is the rapid rate at which information and knowledge are growing. In this Knowledge Age, everyone is expected to be a life long learner.[74]. Businesses expect employees to have breadth of knowledge (which may be represented by a horizontal bar “—”) about the business as well as depth of knowledge (which may be represented by a vertical bar “|”) within their discipline (combined to create the “T” shaped employee, see Figure 1.1) .[150, 65] Skills must be regularly maintained and upgraded, new technology assimilated. With the flattening of organizational structure, employees are expected to fill multiple roles within the organization. Furthermore, employees must be adaptable, able to work well in group situations, and share knowledge across the organization while maintaining loyalty within their team³. [65]

Figure 1.1: The "T" Employee

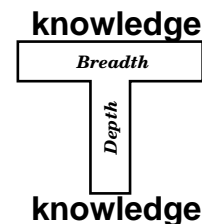

One solution that is growing in popularity and credibility is electronic learning (e-learning), especially web based distance learning. Leveraging communication and computer technology, course content may be delivered at a distance to any suitably equipped

¹Especially recently with the No Child Left Behind Act; see U.S. Government Site <http://www.ed.gov/nclb/landing.jhtml> and the related site No Child Left Behind, Heritage Research <http://www.heritage.org/Research/Education/tst071703.cfm>

²Labor market details <http://www.glc.k12.ga.us/pandp/careerdev/labormarket.htm>

³NOTE: U.S. employees work harder than their European counterparts; putting in 40+ hours per week contributing to high stress and burnout.[153, 172]

location at any time of day. Freeing up the constraints of time and place, learning is transformed from the traditional face-to-face model to one that is characterized as asynchronous and Just-In-Time (JIT).

Table 1.1: Modes of (Distance) Learning

		TIME	
		SAME	DIFFERENT
PLACE	SAME	<i>Traditional Classroom</i>	Computer Based Training
	DIFFERENT	Interactive Video Conferencing	JIT ELearning

For the purpose of discussion, distance learning is taken as a means of teaching students that are separated from their instructor(s) by distance (though time may also be varied). E-learning, then, is that mode of distance learning that employs communication technology, especially internet technology, to deliver educational content independent of time and space. The operational definition of e-learning will be taken to mean the delivery of educational materials and coursework via an internet based learning management system, (see Table 1.1). E-learning provides a phenomenal degree of flexibility for the learner, education provider, and business, alike. Non-traditional students, that is, older students with obligations of work and family that would otherwise deter their enrollment and participation in conventional courses, are obvious beneficiaries. Educational institutions extend the reach of their campuses by offering distance learning courses. Businesses partner with education

providers to enhance the skills of their employees while trimming education expense.

1.1 Trends in Distance Learning

Distance learning had its beginnings in the early 1800's with the first correspondence course being offered in England by Isaac Pitman to teach shorthand to those looking to build their secretarial skills⁴. It was Illinois Wesleyan University in Bloomington, Indiana that offered the first correspondence course in the United States. In the late 1800's William Rainey Harper, considered to be the father of distance learning, developed a correspondence program in Chautauqua, New York and later extended the method when he became president of the University of Chicago .[5] The medium that these courses employed was print (see Appendix A).[110]

1.1.1 Technology

Since the introduction of distance learning courses there have been a number of advances in the technologies associated with delivering educational content remotely. These technological advances may be used to identify generations within distance learning (see Appendix E, also [148, 169, 42]). James C. Taylor in his keynote address to the 20th ICDE World Conference on Open Learning and Distance Education identified five such generations. The first generation, referred to as the *Correspondence Model*, delivered course content primarily through printed materials. The second generation, *Multi-Media Model*, used multiple media formats including print, audio-cassette, videotape, computer based training, and video disks. The third generation, *Tele-learning Model*, used video and telephony together to provide teleconferencing, videoconferencing, and TV/radio broadcasts. The fourth generation, *Flexible Learning Model*, focused on the use of computing technology, especially interactive multimedia. This generation also includes the Internet. The

⁴see Issues and Controversies www.2facts.com

fifth and current generation, *Intelligent Flexible Learning Model*, sees a greater reliance on Internets and intranets. Online material and wired campuses are available anytime and anywhere. Interactivity has improved to the point that systems may be completely autonomous.[173, 110]

As technology becomes more ubiquitous and the communication infrastructure faster, cheaper, and more pervasive throughout the world, e-learning options and developments will continue to grow. Already universities are requiring students to be fluent in the use of computing technology.[74] It is predicted that by the year 2012, all schools, colleges, and universities, will at a minimum be using blended instruction (a combination of computer mediated and face-to-face instruction) routinely to educate their students. Evolution of education methods and strategies will need to keep pace in order to make effective use of the new capabilities.[74]

1.1.2 Enrollment

Another factor affecting distance learning is the growth of student enrollment. The high school class of 2009 is projected to be the largest in U.S. history.[74] College enrollment is expected to grow by 16% over the next decade [74]. Enrollment in higher education has also seen increases in minority, female, and non-traditional adult students [169]; moreover, the trend is expected to continue through 2012 (see Figure 1.2.)

This growth exceeds the current capacity of colleges and has necessitated an increase in distance learning offerings. Figure 1.3 reflects this phenomenon depicting the expected growth in number of postsecondary institutions offering distance learning courses through 2001.

Figure 1.2: Bachelor Degrees Conferred Projected Through 2012, by Gender

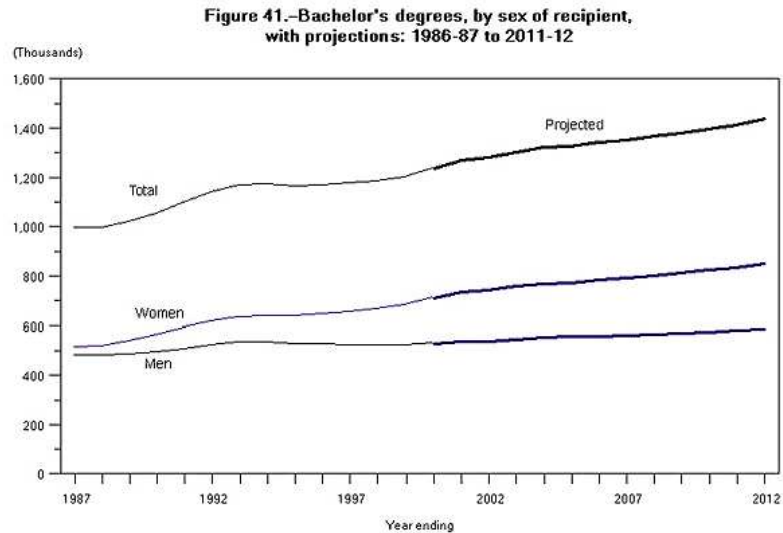

SOURCE: U.S. Department of Education, National Center for Education Statistics, "Degrees and Other Formal Awards Conferred" survey; Integrated Postsecondary Education Data System (IPEDS), "Completions" survey; and Earned Degrees Conferred Model.

Figure 1.3: Distance Education Offerings and Enrollment

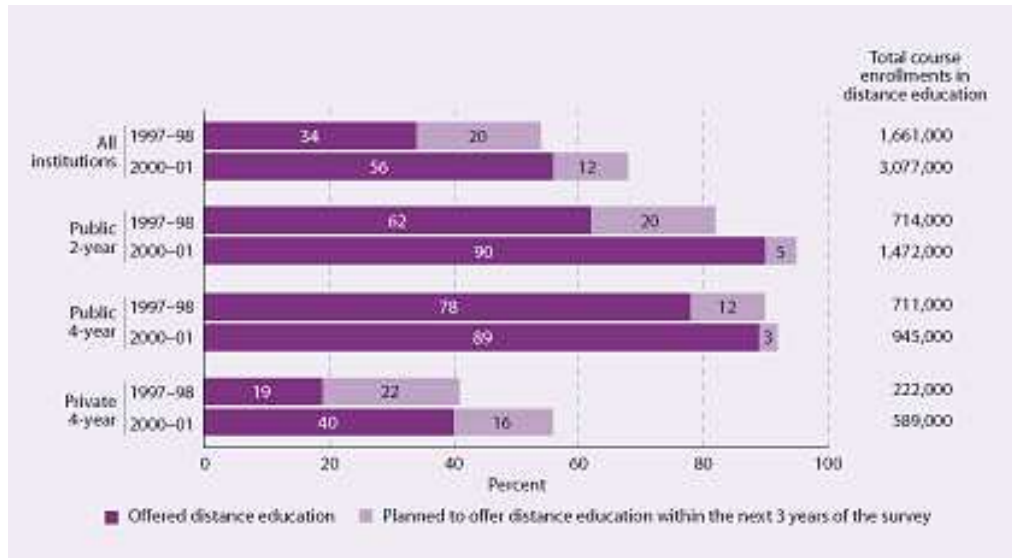

”DISTANCE EDUCATION OFFERINGS AND ENROLLMENT: Percentage of 2-year and 4-year postsecondary institutions offering distance education courses or planning to offer them within the next 3 years of the survey and total course enrollments, by type of institution: 1997-98 and 2000-01” [191]

The profiles of current students are different from their predecessors. College-aged students trained by sound bites, half-hour sit-coms, and video games have little tolerance for delays, live in the moment, multitask, prefer doing things rather than knowing, prefer small modules and short programs, and are willing to shop around to find courses that meet the demands of busy schedules and life circumstances.[74] Adult learners, on the other hand, are goal and relevancy oriented, are motivated by career advancement, and are self-directed, autonomous learners.[74] Colleges and universities are searching for ways to expand their campuses to attract and retain these students. Limitations of infrastructure and funding, however, have made it difficult. One solution has been to extend course offerings through satellite campuses and expanded distance education programs. (see Table 1.2).

Modern students are also more willing to sample courses from multiple institutions. Because of the convenience and availability of online courses, students select courses that are expedient. It does not matter which institution offers the course or where the institution is located as students expect course work will transfer later to the institution that they will finally earn a degree from (if at all.) [74]

1.1.3 Faculty

Faculty, likewise, are experiencing a transformation as more distance learning courses are coming online. Roles are changing to accommodate the new teaching technologies. Rather than a single individual having the entire responsibility for a course, now a team approach is employed. A portion of the team is responsible for assuring that the technology is working, other members develop and support the software, while the professor defines the content and provides feedback. The shift in roles is termed "unbundling".[74, 46]

Another way in which faculty must adapt is in the skills needed to support a distance learning course. Instructors must learn not only the new technology but how it conforms to and transforms the teaching paradigm. Traditional classroom techniques are insufficient for

Table 1.2: Expanding distance education to allow for the completion degree programs

Table 8. Percent of all 2-year and 4-year Title IV degree-granting institutions offering any distance education courses, and the percent that had college-level degree or certificate programs designed to be completed totally through distance education, by institutional type and size: 2000–2001

Institutional type and size	Offered any distance education courses ¹	Programs designed to be completed totally through distance education							
		Any college-level degree or certificate programs		Degree programs			Certificate programs		
		All institutions ²	Institutions with distance education courses ³	Degree programs at either level ³	Undergraduate degree programs ³	Graduate/first-professional degree programs ⁴	Certificate programs at either level ³	Undergraduate certificate programs ³	Graduate/first-professional certificate programs ⁴
All institutions.....	56	19	34	30	21	35	16	12	13
Institutional type⁵									
Public 2-year.....	90	22	25	20	20	†	15	15	†
Public 4-year.....	89	47	53	48	28	43	25	13	18
Private 4-year.....	40	14	36	33	19	28	14	10	10
Size of institution									
Less than 3,000.....	41	11	27	22	16	21	12	11	6
3,000 to 9,999.....	88	32	37	34	25	38	14	12	12
10,000 or more.....	95	49	51	47	27	57	30	16	30

† Not applicable for 2-year institutions.

¹Based on the estimated 4,130 2-year and 4-year Title IV-eligible, degree-granting institutions in the nation.

²Based on the estimated 2,320 institutions that offered any distance education courses in 2000–2001.

³Based on the estimated 2,170 institutions that had undergraduate programs and that offered any distance education courses in 2000–2001.

⁴Based on the estimated 1,080 institutions that had graduate or first-professional programs and that offered any distance education courses in 2000–2001.

⁵Data for private 2-year institutions are not reported in a separate category because too few private 2-year institutions in the sample offered distance education courses in 2000–2001 to make reliable estimates. Data for private 2-year institutions are included in the totals and in analyses by other institutional characteristics.

NOTE: Although 2-year institutions do not offer graduate degrees, they sometimes offer individual graduate courses.

SOURCE: U.S. Department of Education, National Center for Education Statistics, Postsecondary Education Quick Information System, "Survey on Distance Education at Higher Education Institutions, 2000–2001," 2002.

delivering a successful distance learning course. The instructor must learn to be organized, to be a facilitator, a trainer, a coach, a problem solver, and above all to communicate well and in a timely fashion with students. Teaching distance learning courses is much more time consuming and demanding than a traditional face-to-face course.[74, 77, 69]

Full time faculty are troubled by these trends. Colleges seeking cost cutting strategies are leveraging distance learning technologies, hiring less full time staff, and look for nontenured part time employees to fill the gaps. Existing full time staff are given larger

class loads. Faculty teaching distance learning courses are feeling exploited, believing that they are doing more work for no additional compensation. More disconcerting is the current effort of colleges to do away with tenure. Faculty, especially those involved with teaching distance learning courses, have responded by demanding more pay and reduced workload.[74]

1.1.4 Academic

Knowledge is growing exponentially, doubling every four years [74]. Printed materials are obsolete almost as soon as they are printed. Publishing content on an internet/intranet allows for better quality control, timeliness, and cost management for things such as updates, corrections, addendum, and revisions. However, with the accessibility and freedom of the Internet also come issues of ethics and ownership. Copyrights and trademarks are being ignored regularly. Cheating and plagiarism are commonplace.[134, 152, 155, 170, 187] Laws are slow to catch up, though many would prefer they never did.[31, 112, 127, 179]

Henry Ford, the famed industrialist, is noted for his utilization of the assembly line for the mass production of automobiles. Educators adopted a similar mass production model (Fordism) and have used the process to educate students for the last 80 years.[151, 45, 20, 19] Technology is transforming the education landscape, smashing the "one size fits all" mindset. For example, with e-learning, instruction becomes more individualized, learner-centered, and self-directed. Students choose their own path for accomplishing curricular goals and objectives.[74] Those who are "quick studies" may move through material rapidly. Others may wish to review frequently, iteratively, until they have built confidence and the requisite skills for mastery.

The proliferation of courses offered and inconsistencies in delivery, assessment, and content have raised the question of competency on the part of both students and instructors. Even with the existing requirements for graduation (from secondary and post secondary

institutions) industry still finds that it needs to spend an inordinate amount of resources to bring skills of (new) employees up to par. Industry is pushing for a certification rather than a diploma as measures of assurance of employee skills.[158, 156] As a result, emphasis is moving away from course completion to one of competency (e.g. the Ohio Graduation Test⁵). Schools are being graded on the performance of their students on standardized exams nationwide. Many are found wanting. The recent passing of the No Child Left Behind Act, the Highly Qualified Teachers initiative, and the State-by-State Report Card for Higher Education⁶, are examples of attempts to build accountability back into the U.S. education system.

33% of online students enroll with for-profit education providers.[74] In addition, the home schooling movement is expected to remain strong and to evolve into a home-college movement with a strong reliance on distance learning.[74] To remain competitive and relevant, higher education institutions are seeking innovative strategies to deliver education. For example, many are exploring partnerships with other colleges and businesses in order to share technology and to distribute the burden of developing distance learning technologies and content. Standards are being developed and content is being crafted to be reusable and independent of software platform (see Sharable Content Object Reference Model, SCORM, and learning objects). Continuing education programs are being nudged toward mainstream academics (decentralization). Finally, with the decline in the number of traditional campuses public and private universities are merging.[74]

While no one expects face-to-face learning to become obsolete, it is clear that educational institutions are beginning to face the same pressures that manufacturing industries faced in the previous two decades when confronted with computer automation. As with

⁵see Ohio Graduation Exam <http://www.ode.state.oh.us/proficiency/OGT/default.asp>

⁶see No Child Left Behind <http://www.ed.gov/nclb/landing.jhtml?src=pb>, Highly Qualified Teachers <http://www.ed.gov/nclb/methods/teachers/hqtflexibility.html>, and Report Card <http://measuringup.highereducation.org/2002/reporthome.htm>

manufacturing, the education landscape is likely to be radically different when the smoke clears.

1.1.5 Business

Businesses embrace e-learning as a means for building competitive advantage. Cost cutting while enhancing the skills of their labor force are two of the predominant drivers cited for adopting e-learning. With e-learning, it is no longer necessary to search for (scarce) training events, upset project timelines due to training schedule conflicts, or send employees away for training. Travel costs, time off task, and productivity losses are minimized as employees use JIT e-learning on site whenever a free block of time and/or opportunity presents itself.[1, 159] The flexibility and timeliness of e-learning content provides individuals the ability to customize and streamline their learning and to focus on only what is relevant and needed.

On the other hand, e-learning is no panacea for poor business strategy. Organizations must carefully consider the strategic impact of e-learning on their operations. Is e-learning important to the core business? Is e-learning a support tool? Is e-learning a key component for evolving business strategy? Is e-learning crucial to the viability of the organization? Answers to these questions (taken from McFarlan's strategic importance framework) would help to determine whether e-learning was a good fit and worth the (sizable) investment.[44]

Considerable effort is being made on devising suitable metrics to understand the contribution e-learning makes to business. Measuring the effectiveness of any training program, while difficult, may be done by gauging the impact on the organization at a number of interrelated levels: 1) the trainee's perception of effectiveness, 2) the assessment of trainee learning, 3) performance as observed by the trainer and manager, 4) impact of training on the business, and 5) the total training expense compared with generated outcomes, i.e. return on investment (ROI). Ultimately, the tangible benefits (e.g. reduction in costs and

staff turnover, increase in quality and productivity) must be quantified and compared to administrative and training costs associated with the e-learning initiative.[157, 146, 44]

Organizations with a culture of learning (e.g. learning organizations and corporate universities) stand to gain significant momentum by adopting e-learning. Developing employees as lifelong learners is key to sustaining an e-learning initiative.[102] Recognizing this trend, universities are partnering with companies to build viable e-learning programs for both management and employees. In addition, businesses, cognizant of the value and newfound credibility of e-learning, are becoming more accepting of (i.e. willing to hire) employees who hold distance learning degrees.[74]

1.2 Controversy

”Distance education technologies are expanding at an extremely rapid rate. Too often, instructional designers and curriculum developers have become enamored of the latest technologies without dealing with the underlying issues of learner characteristics and needs, the influence of media upon the instructional process, equity of access to interactive delivery systems, and the new roles of teacher, site facilitator, and student in the distance learning process.”[164]

As is often the case in rapid growth industries, capability outstrips the capacity to use innovations wisely (witness the explosive growth of the Internet and how the judicial system had to play catch up to handle all the new issues with respect to privacy, theft, et cetera.) Development and application of computing and communications technology in the classroom have been welcomed but are lacking the theoretical underpinnings to put to effective use [164, 122]. As a consequence there have been a hodgepodge of efforts and initiatives to apply e-learning technologies which have yielded mixed results.[137, 46]

The National Postsecondary Education Cooperative (NPEC), a voluntary partnership established by the National Center for Education Statistics (NCES) that includes federal and state government agencies and postsecondary institutions, commissioned a study on

the use of technology to access postsecondary education.[138] The report focused on four themes relating to technology mediated distance learning. The themes were: 1) general access to postsecondary education, 2) access to technology based learning, 3) preparation of students and teachers to use technology for postsecondary education, and 4) the effectiveness of such technology.[138]

The study found that, in general, technology improved participation in postsecondary education. However, there was a noted disparity among users with access to current computer technology (HAVES) and those without (HAVE NOTS). The disparity, termed the "digital divide", was found to exist between the races, two parent versus single parent households, older versus younger adults, and individuals with disabilities versus those without. While gains have been made in closing the gap, generally, the disenfranchised groups were less involved in technology mediated postsecondary education than were their more advantaged counterparts.[138]

The digital divide also was found to exist between educational institutions. Large universities were found to have greater access to technology than were smaller colleges. Three areas of weakness were cited: 1) lack of communication and networking infrastructure, 2) lack of good quality, reliable middleware, and 3) lack of cooperation on behalf of internet providers to work with smaller schools. The differences were largely attributed to matters of economics.[138].

Student preparedness was addressed by focusing on student exposure to computer and Internet technology at the K12 grade levels. The percentage of K12 schools with Internet access was at 98% in 2000, up from 35% in 1994.[138] Internet to the classroom, likewise, showed a significant increase, up from 3% in 1994 to 77% in 2000.[138] The student to computer ratio was 5 to 1 and the student to Internet capable computer ratio was at 7 to 1 in the schools surveyed. These figures were deemed sufficient for effective instruction.[138] While this news is encouraging, two issues must be taken into account. First, schools

with a high minority enrollment and schools with a high enrollment of students at poverty level had significantly lower percentages than those stated. Second, the numbers do not reflect the condition of the equipment, vintage of software used, or quality and speed of the Internet connection.[138]

99% of the K12 teachers surveyed reported having access to the Internet and computers within the school. While newer teachers were more likely to use computers for meeting curricular objectives, 66% of the teachers surveyed said that they used computers or the Internet for instruction in the classroom.[138] Over 40% of the teachers said that they made assignments that required the use of computers and/or the Internet.[138] Once again, schools with large enrollments of minority or impoverished students were less likely to make computer or Internet assignments than their counterparts.[138]

Even for schools that made frequent use of computers and the Internet, the quality of instruction was questionable.[15, 138] Reasons cited included: the lack of teacher training, lack of release time to create lessons using technology, unreliable hardware, and outdated software. Even teachers that adopted the technology into their classrooms did not change their traditional methods of teaching. As a consequence, computers were relegated to "the back of the classroom" and were used for menial tasks.[138]

Of particular interest to this discussion was the fourth theme of the report. To ascertain the effectiveness of technology mediated instruction delivered at a distance, (then) current research on the topic was examined. Three measures of effectiveness were predominant in the body of works studied: 1) student performance, 2) student attitudes, and 3) student satisfaction. Consensus was that technology mediated distance learning was as effective, if not more so, than traditional face-to-face instruction.[12, 138] However, the report goes on to say that these findings have serious flaws.

The NPEC report calls into question the validity and quality of much of the research examined. The major criticisms focused on the inadequate methods employed by researchers.

Lack of adequate controls, poor statistical methods, anecdotal and second hand reporting, and bias were among the indictments made (see Table 1.3 for a complete listing.) A parallel study prepared for the American Federation of Teachers (AFT), the National Education Association (NEA), and the Institute for Higher Education Policy found similar problems. Perhaps the most damning statement was as follows;

”It is important to emphasize that, despite the large volume of written material concentrating on distance learning, there is a relative paucity of true, original research dedicated to explaining or predicting phenomena related to distance learning.” [137, p 2]

Others have also called into question the effectiveness of technology mediated distance learning (e-learning). Messing [115] asks if e-learning students are being adequately provided for or if there is even a need for e-learning. Grubb [62] suggests that e-learning technologies have not matured sufficiently to provide instruction comparable to high quality face-to-face instruction. Dick [40] and Keller [87] find that there is strong resistance on the part of students toward e-learning.

”Surprisingly, more than 50% of the students disagreed totally or to a large extent with the statement that e-learning improved their learning. Students did not regard access to e-learning on campus as a benefit. Students at the school of engineering showed more negative attitudes than students at the school of health sciences.”[87]

Table 1.4⁷ reflects undergraduate student distance learning experiences from 1999 to 2000.

⁷These notations reflect the footnotes indicated in table 1.4

1. “Denominator is total undergraduate population.
2. The denominator in the rows below is the number of undergraduate students who participated in distance education classes.
3. Type of distance education categories are not mutually exclusive.

NOTE: Includes students who participated in distance education at either the institution at which they were enrolled or both the institution at which they were enrolled and another

Table 1.3: Shortcomings of Distance Learning Research, taken from "What's the Difference?" [137]

"Much of the research does not control for extraneous variables and therefore cannot show cause and effect." [137]

"Most of the studies do not use randomly selected subjects." [137]

"The validity and reliability of the instruments used to measure student outcomes and attitudes are questionable." [137]

"Many studies do not adequately control for the feelings and attitudes of the students and faculty-what the educational research refers to as 'reactive effects.'" [137]

"The research has tended to emphasize student outcomes for individual courses rather than for a total academic program." [137]

"The research does not take into account differences among students." [137]

"The research does not adequately explain why the drop-out rates of distance learners are higher." [137]

"The research does not take into consideration how the different learning styles of students relate to the use of particular technologies." [137]

"The research focuses mostly on the impact of individual technologies rather than on the interaction of multiple technologies." [137]

"The research does not include a theoretical or conceptual framework." [137]

"The research does not adequately address the effectiveness of digital 'libraries'." [137]

69% of the total number of students surveyed were equally or more satisfied with electronically mediated distance learning as with traditional instruction. However, upon closer examination of students who hold a strong opinion about e-learning (i.e. "more satisfied" vs "less satisfied"), one finds that there is consistently a significantly larger group of less satisfied students than more satisfied students across all of the schools (see Figure 1.4). This observation may be indicative of the Dick and Keller findings.

Table 1.4: "DISTANCE EDUCATION PARTICIPATION: Percentage of undergraduates who participated in distance education classes at postsecondary institutions, and percentage of participants with various experiences with distance education: 1999-2000"

Distance education characteristics	Total	2-year public	4-year		
			Total	Public	Private not-for-profit
Total percentage participating ¹	7.6	9.0	6.6	6.9	6.1
Percentage of participants ²					
Type of distance education ³					
Live TV/audio	37.3	39.3	34.1	36.6	27.5
Prerecorded audio/TV	39.3	43.8	33.2	31.5	37.7
Internet	60.1	56.4	64.3	61.6	71.5
Entire program available through distance education	29.0	28.8	27.8	27.1	29.8
Level of satisfaction with distance education classes compared with regular classes					
Total	100.0	100.0	100.0	100.0	100.0
More satisfied	22.6	24.0	19.9	20.2	19.1
Equally satisfied	47.1	45.1	51.2	51.1	51.6
Less satisfied	29.6	30.0	28.2	28.2	28.1

institution. Students who participated in distance education only at an institution other than the one at which they were primarily enrolled were excluded. Percentages may not add to 100.0 due to rounding.

SOURCE: U.S. Department of Education, NCES. National Postsecondary Student Aid Study (NPSAS:2000)."; from National Center for Education Statistics at NCES DL undergraduate participation <http://nces.ed.gov/programs/coe/2002/charts/chart38.asp>.

Figure 1.4: A QQPlot of Distance Learning Students with a Strong Response

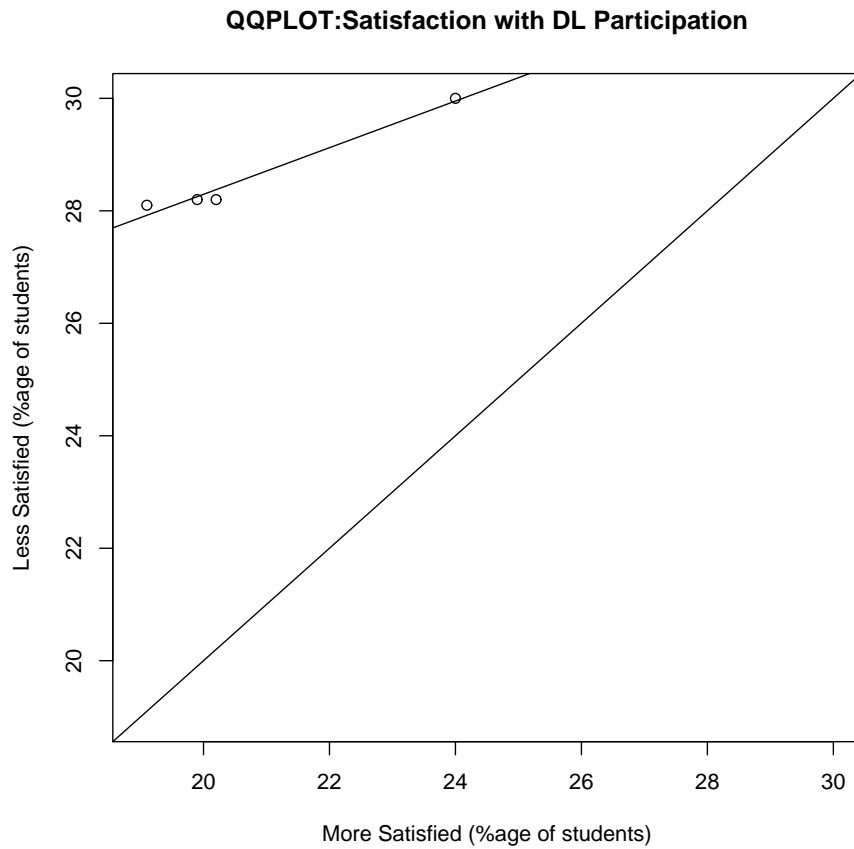

The controversy is far from over⁸. [5, 10, 178, 86] While one would expect educators to be resistant to change and to a technology that could someday put them out of work, it is clear that there are questions that merit answers but have been only poorly addressed.

1.3 The Purpose of this Study

This study will address four of the aforementioned problems associated with distance learning research (see Table 1.3), specifically: 1) the lack of a theoretical framework, 2) the validity and reliability of the assessment instruments used, 3) lack of attention to students'

⁸see The Elearning Critic <http://www.geocities.com/elearningcritic/>.

learning styles, or more specifically multiple intelligences, and 4) will suggest an explanation for why students drop out of e-learning programs, that is, fail to adopt the technology.

Adoption of technology has been and remains a key area of research in the field of Information Technology (IT). A number of theories of diffusion and adoption have been proposed. The Technology Acceptance Model (TAM), proffered by Davis, et al [39, 38], is generally acknowledged for its ability to predict user acceptance and adoption of new technologies. Since its inception in the late 1980's, TAM has been validated and tested for reliability in a variety of contexts including education.[89, 100, 34, 17, 96] The TAM is flexible, allowing for the inclusion of external factors that may influence its primary antecedents; usefulness and ease of use. The TAM will provide the theoretical framework for this study of adoption.

Understanding how students learn is crucial to providing effective instruction. Learning styles describe the modes by which students prefer to learn. It is assumed that maximal learning occurs when learning style is matched by instructional method. There are a plethora of learning style descriptions, most center around the senses; auditory, visual, and kinesthetic. There are also a number of instruments available to measure learning styles, however most lack reliability and validity⁹. [30] Multiple intelligences proposed by H. Gardner [58, 56, 57], often used synonymously with learning styles, identify eight intelligences that everyone is assumed to possess in varying capacities. Each intelligence must meet a specific set of criteria to be identified as such, including being associated with identifiable regions of the brain. Multiple intelligences have been researched for over two decades.[57] A number of instruments exist to assess an individual's multiple intelligences. The most promising is the Multiple Intelligence Developmental Assessment Scales (MIDAS), developed by B. Shearer, shown to be a reliable and valid instrument.[160] Adapting instruction

⁹<http://secondlanguagewriting.com/explorations/Archives/2007/August/LearningStyleisNonsense.html>

to meet a student's learning profile, emphasizing either learning style or multiple intelligence, has been termed differentiated instruction.[177, 176] Differentiated instruction is designed to improve student success, thereby increasing student satisfaction.[90] Students satisfied with instruction are less likely to abandon it. For this study multiple intelligences will be used as a surrogate for learning styles and as a measure of the ability for e-learning to address student needs. The focus will be on how multiple intelligence theory may be used to extend the Technology Acceptance Model and explain student adoption of e-learning technologies.

1.4 Contributions of Research

The extended TAM is a valuable tool inasmuch as it provides a framework against which to gauge a comprehensive, flexible e-learning environment. In the ideal case, such an environment would act as a personal tutor, seamlessly matching instruction with students' needs and empowering students to navigate their own path through complex content in order to meet course and personal objectives. Furthermore, the extended TAM underscores the importance of not encumbering e-learning environments with unnecessarily complex interfaces or impenetrable technological wizardry.

Another advantage of the extended TAM is that it serves as a map, highlighting factors that have received a great deal of attention as well as those that would benefit from further scrutiny. One area that bears closer examination is the connection between student acceptance of e-learning as an instructional tool and actual student mastery/performance with respect to the subject matter. A student's perceptions of his own performance in an e-learning course has been demonstrated to be an imprecise measure of actual content mastery.[53] Even so, many studies rely heavily on perceived rather than demonstrated performance. Moreover, few studies attend to the issues that cause students to drop out of e-learning experiences and query only those students that remain.[137, 138]

Before e-learning technology can be completely embraced by educators there must be an understanding of how e-learning will transform the teacher/student paradigm. Existing learning theories and philosophies must be carefully weighed against what is understood about diffusion and acceptance of technologies. Which factors impact a student's learning from an electronic source and which influence the acceptance of that source as a trusted e-learning surrogate instructor must be clearly defined. Doing so will provide a model that will empower students to choose an optimal e-learning experience through which learning outcomes and subject mastery may be achieved. Or, steer them toward face-to-face learning instead.

1.5 Summary

This chapter introduced the concept of e-learning. The growing momentum and obvious potential of this educational medium is not to be ignored. Students, especially non-traditional students, stand to benefit greatly from the flexibility that e-learning provides. Educational institutions from K-12 through graduate schools and beyond are cautiously embracing the technology as a means of addressing the growing demands placed upon them. Businesses are looking to employ technology mediated distance learning as a cost effective means to grow employee competency and skills, to leverage knowledge, and build competitive advantage.

However e-learning is not without its detractors. Some educators see e-learning as a potential threat. Others point to the lack of credible research and encourage caution. This research will address some of these shortcomings while examining the contributions that multiple intelligence theory can provide to the understanding of the adoption of e-learning technology.

CHAPTER II

LITERATURE REVIEW

To begin, consider a simplified framework for a typical learning system (see the upper portion of figure 2.1). For a given course there exists a set of skills or content to be conveyed (identified and described by goals and objectives), an instructor to deliver appropriate instruction (delivery agent), and student(s) to receive the instruction for the purpose of mastering the course objectives. All of this occurs in an environment designed to encourage learning; i.e. a classroom. To ascertain whether learning occurred (objectives met) and to what extent, students undergo some form of assessment. Students identified by the assessment as having mastered the material/skills may be said to have had a successful learning experience. Successful students will graduate and move on. The others will be offered an opportunity for remediation or may decide to pursue some other opportunity.

Each component of the above scenario has undergone decades of intense scrutiny by researchers. Each contributes a myriad of factors to add to the patchwork that is education. No one set of factors has been identified as that perfect mix that constitutes the ideal educational paradigm. Almost yearly, initiatives are undertaken to restructure education, to incorporate some new twist purported to improve upon the educational process. . While the overwhelming wealth of educational research makes it difficult to decide which strategy to adhere to, what is clear is that this body of work cannot simply be ignored.

Move now to e-learning, wherein technology replaces the role of instructor (see the

lower portion of figure 2.1). A sameness of process applies. That is to say that content must still be delivered via a delivery agent. Environment continues to impact upon the quality of education provided. Students still bring to the table their own individualized experiences, strengths, and weaknesses. Above all, mastery of learning outcomes continues to be the measure of success. Therefore, many of the same factors and issues that govern face-to-face learning must continue to apply.

Note, it does not necessarily follow that e-learning must be conducted in the same manner as traditional learning. One does not simply swap machine for instructor and teach as before; moving from face-to-face to machine-to-face instruction [14]. The opportunity to make fundamental changes in teaching paradigms does exist. Most notably that of evolving from a teacher-centric to a student-centric methodology, i.e. transforming from a "push" (teacher driven, teacher designed) to a "pull" (student needs driven, information on demand) educational system.[25] Even so, the core educational process remains. Specifically, content must be delivered to a student at some place via some agent with results assessed in some fashion.

Figure 2.1 depicts our simplified learning model and includes the two delivery processes (face-to-face, machine-to-face) described above. The model is segmented into five regions; content, delivery agent, environment, student, and assessment. Content is filtered through the delivery agent, is impacted by the learning environment, is assimilated by the student(s), who must then show mastery. Depending upon the instructional design, either constructivism, cognitivism, or behaviorism, instruction follows a prescribed plan intended to elicit learning in the student. Included in the figure is a sampling of relevant factors and the inclusion of a feedback mechanism whereby the student(s) may interact with the delivery agent. Also represented in this diagram is the more common video conferencing style of distance learning, where the instructor's lesson is broadcast to a distributed audience in real-time.

Figure 2.1: A Simplified Model of Learning Systems

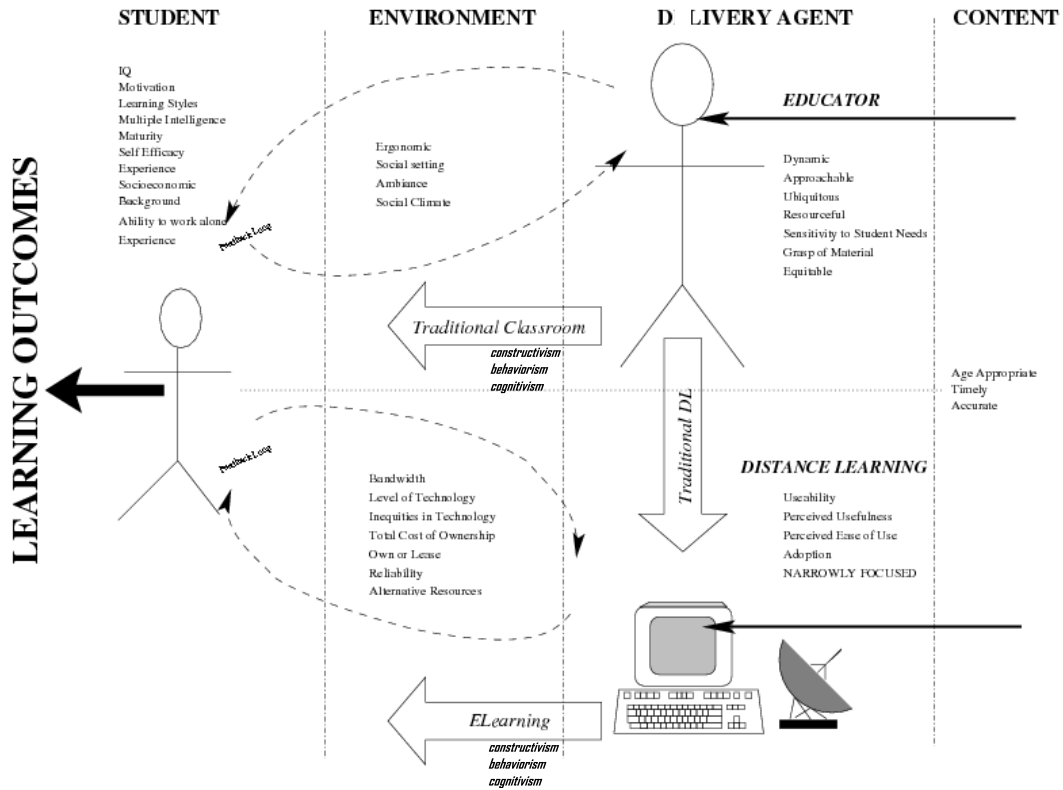

Given that learning has the potential to take place in a technology mediated (e-learning) environment [36, 99, 83], it is clear that the surrogate delivery agent will make or break the learning experience. The capacity for the delivery agent to provide stimulating interactive lessons on demand and the degree to which a student embraces the e-learning venue significantly influence learning outcomes. It follows that an understanding of e-learning as an educational process must address not only how the technology transforms education, but also how students relate to the technology. Upcoming sections explore how each segment of the simplified educational framework is conformed in an e-learning environment. The focus in all cases is on how students engage with e-learning. As the framework is developed it is possible to identify the position and importance of an enhanced technology acceptance

model.

2.1 Content

Dividing content into chunks that are reusable, adaptable, and that may be combined into various units is a recent innovation in e-learning that culls some of the best features of object oriented programming. A learning object, the term used to describe a chunk, is "...the smallest independent structural experience that contains an objective, a learning activity, and an assessment." [175] By their very nature learning objects are intended to be reusable and portable (read electronic/digital).

Learning objects are composed of content and meta-data. The meta-data describes the attributes, behavior, and interface of activation [175] of each object. Wiley [189] identifies five types of learning objects; single-type, combined-intact, combined-modifiable, generative-presentation, and generative-instructional. His taxonomy of learning objects focuses on the number of elements contained in an object and its degree of re-usability as criteria for classification (see table 2.1).

Learning objects are described as building blocks.[70] As such, they may be combined in a number of ways to build any number of (learning) edifices. But with this degree of flexibility comes the need for standardization; a necessity if learning objects are to be a viable instructional design tool. IMS Global Learning Consortium, Inc. (IMS), the Institute of Electrical and Electronic Engineers (IEEE), the Alliance of Remote Instructional Authoring & Distribution Networks for Europe (ARIADNE), and the Aviation Industry CBT (Computer-Based Training) Committee (AICC) each have been working on the specifications and standards for learning objects. SCORM (Shareable Content Object Reference Model), a web-based e-learning standard, is built upon the standards set forth by these organizations. SCORM¹ boasts interoperability, accessibility, and re-usability of web-based

¹SCORM Conformance Documentation <http://www.adlnet.org/scorm/history/2004/>

Table 2.1: Wiley's Taxonomy of Learning Object Types [189]

Learning Object Characteristics	Single Type Learning Object	Combined-intact Learning Object	Combined-modifiable Learning Object	Generative-presentation Learning Object	Generative-instructional Learning Object
Number of elements combined	One	Few	Many	Few-Many	Few-Many
Type of object contained	Single	Single, Combined-intact	All	Single, Combined-intact	Single, Combined-intact, Generative-presentation
Reusability of component objects (not applicable)	Low	Low	High	High	High
Common function	Exhibit, display	Pre-designed instruction or practice	Pre-designed instruction and/or practice	Exhibit, display	Computer-generated instruction and/or practice
Extra-object dependence	No	No	Yes	Yes/No	Yes
Potential for inter-contextual reuse	High	Medium	Low	Low	High
Potential for intra-contextual reuse	Low	Low	Medium	High	High

learning content.[175]

There are a number of authoring tools that use XML and are SCORM compliant (e. g. ILIAS and eXe², see also Appendix C). While not every subject may be appropriate for an e-learning environment [28], much is being done to make the development of learning objects convenient and simple for instructional designers. Table 2.2 illustrates one practitioner's criteria for determining whether or not content is a good match for an e-learning environment.

documents.cfm

²<http://www.ilias.de/>

<http://exelearning.org/>

Table 2.2: Practitioner's Criteria for Developing Web-Based Training Tools, From *An E-Learning Primer* [29]

Criteria for Determining Suitability of Content for Conversion to Web-Based Training
1. Does the number of potential users justify the cost of development?
2. Does the target audience have computers and access to the Internet?
3. Will the target audience be receptive to web-based training?
4. Will Internet distribution of the content provide a method of instruction that is easier, faster, cheaper, safer, and/or more engaging than other formats in current use?
5. Is the content suitable for chunking in small units as reusable learning objects?
6. Is the content adaptable to embedded learner control, and will the intended instruction become more effective if the user controls the pace of delivery?
7. Can the content be more effectively delivered with multiple technologies, i.e. multimedia (sound, video, animation, et cetera)?
8. Will the content be strengthened from computer-generated illustrations and animation?
9. What impact will immediate assessment feedback have on users?
10. Is the content adaptable to either linear or dynamic navigation?
11. Will the content benefit from dynamic links to other external web sites?
12. Will the content be strengthened by the use of supplementary audio used as instructional commentary or explanatory sound effects?

Major advantages given for using learning objects are: 1) flexible reuse, 2) ease of maintenance, 3) ability to restructure objects to accommodate the learner, 4) interoperability between compliant learning management systems, 5) compliance to learning standards and competencies, and 6) from a content provider's point of view, the value added from reuse rather than recreate [44, 60]. Some of the drawbacks of learning objects are: 1) the degree of effort necessary to develop learning objects and consequent costs, 2) the final format of the metadata, including how objects should be referenced, stored, and retrieved, 3) the level of granularity of the learning objects, 4) the sterility of learning objects when divorced from context, 5) standardization especially concerning delivery and learning management systems, and 6) copyright and content ownership.[44, 60, 61] Learning objects are still under development and a source of much debate.[52, 140, 175]

While packaging learning modules is not a new concept (consider books, filmstrips, workshops, et cetera) the potential and flexibility of learning objects seems a natural fit for electronic and web-based learning systems. The potential savings of effort and cost for not having to reduplicate effort for every course or subject taught by every teacher every year in every institution is immense. However, one is cautioned not to let the technology drive educational pedagogy, but to keep technology in its proper perspective as a neutral conveyance of content.[186]

2.2 Instructor/Delivery Agent

There has been a renewed interest in the quality of instruction pre-kintergarten through 12th grade throughout the United States. With the No Child Left Behind laws in effect, all teachers must have demonstrated their qualifications by the end of the 2005-06 school year. Highly qualified teachers are those "...with full certification, a bachelor's degree and demonstrated competence in subject knowledge and teaching. (Core subjects include English, reading or language arts, mathematics, science, foreign languages, civics and govern-

ment, economics, arts, history and geography).” (NCLB website: <http://www.ed.gov/nclb/methods/teachers/teachers-faq.html>) In general, effective instructors (delivery agents) are those who are knowledgeable in content area and in teaching methods, are organized and communicate with clarity, and who exude a warmth and enthusiasm toward their students and subject matter.[192]

Six teaching functions have been associated with effective instruction. They are: 1) review of previous material, 2) presentation of new material, 3) provision for guided practice, 4) appropriate feedback with necessary correctives, 5) provision for independent practice and exercise of concepts, and 6) long term review (weekly, monthly).[192] Above all, effective instructors must be flexible and able to customize material to meet the special needs of students of all abilities (high and low).[192]

D. M. Merrill [114] examined current teaching theories and instructional models. He found that all of the works studied participated in what he termed the “first principles of instruction”. These principles are problem-based, and seek to actively engage students in four phases of learning: 1) *activation*, building on what students already know, 2) *demonstration*, showing rather than telling what is to be learned, 3) *application*, where students practice applying what was learned, and 4) *integration*, in which students take ownership of what was learned (see figure: 2.2).

Merrill’s five principles closely parallel the six functions of an effective teacher.

”These five first principles stated in their most concise form are as follows:

1. Learning is promoted when learners are engaged in solving real-world problems.
2. Learning is promoted when existing knowledge is activated as a foundation for new knowledge.
3. Learning is promoted when new knowledge is demonstrated to the learner.
4. Learning is promoted when new knowledge is applied by the learner.

Figure 2.2: Merrill's Phases for Effective Instruction

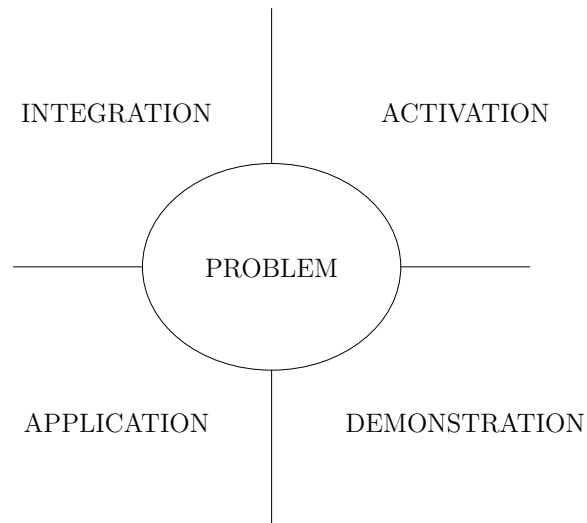

5. Learning is promoted when new knowledge is integrated into the learner's world.”[114]

Merrill's five principles undergird the education theories and models examined and provide a framework for understanding each. Merrill notes that while no one theory or model contained all five principles, none ran counter to them. This was true independent of either the educational theory or philosophical orientation to which a model belonged (see Appendix F). Any differences in models or theories was ascribed to vocabulary and which of the five principles were emphasized.[114]

To be effective, instruction whether provided face-to-face or over a distance must be held to the same stringent standards. Moving to an electronic format should not be a license for poor instruction or methodology.

2.3 Environment

A classroom may be viewed as an *ecological system*. [192] From this perspective the environment and its inhabitants — the students and teacher — are forever interacting one with another. The dynamic and opportunistic nature of the classroom has been shown to

influence student behavior, teaching, learning, and classroom management.[192]

The physical layout of the room establishes authority. It defines how and even if participation or feedback is to occur. The classroom environment impacts the perceived social distance between a student and his peers, and a student and his teacher. Classrooms may serve to distract or enhance learning through lighting, seating, sound, climate, condition and availability of resources, creating expectations, et cetera.[54, 184] Even where an individual chooses to sit determines how well he can hear and see the instructor. According to Paul Nolting³, there is a "golden triangle of success", wide at the front and narrowing at the rear of the classroom (lecture hall), in which the most learning occurs (see Learning <http://www.oncourseworkshop.com/Learning014.htm>). Successful face-to-face instruction carefully attends to these matters and orchestrates the learning activities to minimize the potential negative influences of the environment, and to maximize the potential for growth.

Teaching at a distance, rather than ameliorating these issues, serves to exacerbate them. In addition, e-learning introduces its own unique set of environmental challenges. An obvious challenge is the perceived failings of existing technological capacities to accommodate instruction. However, given the rapid advances currently being made in the communication and computing fields, this condition is fluid and unlikely to remain a problem for very long. So rapid are changes that at issue is not the capability of the technology but rather the ability of software tools to keep pace, the ability of designers and instructors to fully utilize capacity, and the students' access to the technology which provides communication paths to online courses and materials.

This last point may be the most constraining. The technology that students own is a hodge podge from the ancient to the bleeding edge. This is also likely to be true for the software suites that they own. Two options exist. The first option is to expect that every student enrolled in an online course has access to the most current technology (if not

³see <http://oncourseworkshop.com/Learning014.htm>

owned then provided by the institution.) This option may carry a price tag that is too great for either students or institutions to sustain. The second is to set a baseline capability for the technology required for participation in online courses. However, a minimal capability by definition precludes the latest innovations in technology. Even if such a baseline were to be a snapshot of today's technology, it could not capture tomorrow's innovation, a scenario that may be replayed a number of times within a lifespan of a degree program.

Still, the favored approach has been to work from a baseline. Courseware developers have responded by developing products that accommodate this lowest common denominator and do not overtax the capacities of the technology (e.g. throughput bandwidth of dial-up versus broadband networks). The consequence is that most distance learning courseware is predominantly text-based [130], relying heavily on the reading level of the material, reading ability of the student, and ignoring whether or not that is the optimal learning style for the individual or the optimal presentation format for the content (see also appendix C).

Even with a modest baseline, students and instructor's skills are challenged.[50] It is all too common to attend a talk only to watch the speaker struggle with the technology for a hefty portion of the allotted time. Participants who have to endure a protracted delay are often disgruntled and take a dim view of the value of technology[66] and the presentation. If things do go smoothly it is often due to the efforts of a small army of technicians who groomed the equipment before hand. While this may serve a presenter well, such service is rarely available to students who are left to fend for themselves. A consequence is that students with technical skills and experience are more likely to have a favorable attitude toward e-learning. Those who do not and are left without recourse, when faced with unreliable systems are more likely to withdraw and harbor a resentment toward the technology.[87, 109, 120]

Clearly, environment sets the backdrop against which any course is executed. An en-

environment that is conducive to learning will appropriately fade into the background. However, an environment that is hostile to learning will become a source of frustration, consuming the resources and goodwill of all participants.

2.4 Student

”The students of today are not the students of yesterday” is a belief becoming firmly entrenched in the minds of educators. Educating students in the same manner as was the wont when educators themselves went to school is no longer held to be a means of delivering quality instruction⁴. [143] In response, educators are scrambling to find ways to hold the interest of young people raised on video games, television, cell phones, text messaging, instant messaging, and the Internet. The ramifications of this belief are far reaching. If it is true then a number of questions arise. Are *connected* students, those with information technology tools at their fingertips, predisposed to e-learning? Will *dis-connected* students, those growing up in technology impoverished settings without access to information technologies, be either accepting of or reluctant to using e-learning? Do adult learners differ dramatically from their younger counterparts with respect to their acceptance of e-learning? What factors encourage success in e-learning? What factors raise barriers? What work has been done to understand these issues?

Transitioning to a technology mediated method of instruction will not in and of itself transform education nor guarantee every student will learn. [14] Institutions and content providers realize this and offer pretests to assess whether or not e-learning is the right match for a prospective student⁵. Even with pretests, however, the dropout rate of e-learning courses continues to be higher than in face-to-face courses. [185, 135] For students to have success, they must accept and adopt the technology as surrogate instructor, since to reject

⁴see Building Professional Learning Communities (PLCs) and School Change at <http://www.ed421.com/?p=284>

⁵E.g. see Successful Online Learner <http://etech.ohio.gov/jcon/portal>

the technology is to deny the learning opportunity outright.[75, 36] Therefore, technology acceptance becomes a crucial component in the understanding of students' engagement with e-learning. Understanding behaviors of individuals with respect to technology acceptance begins with the Theory of Reasoned Action.

2.4.1 Acceptance Models⁶

Fishbein and Ajzen [48] developed the Theory of Reasoned Action (TRA) to predict and explain behavior that is consciously intended and under the direct voluntary control and will of an individual. It has been successfully applied in a number of areas including medicine and technology, and across cultures.[123]

Given a clearly defined behavior or system, the Theory of Reasoned Action (see figure 2.3) purports that action (Actual System Use) is a direct consequence of the intent of the individual to use or employ such a system (Behavioral Intention to Use, BI). The model asserts that intent (BI) is a function of Attitude Toward Using (A), Subjective Norm (SN), and the weight ascribed to each depending upon the circumstance, conditions, and inclination of a given individual (Relative Importance). Attitude Toward Using captures the perceived value placed upon the action by the individual, specifically, whether the net outcome is a positive/good or a negative/bad. The Subjective Norm captures the external motivations and social pressures to perform the action in question.

Attitude Toward Using is itself contingent upon two factors; an individual's personal beliefs in the outcome of the action be it good or evil (B), and evaluation of the advantages/disadvantages of the action (E). Finally, Subjective Norm is also dependent upon two factors; Normative Beliefs (NB) and Motivation to Comply (M). Normative Beliefs de-

⁶Cynthia K. Riemenschneider in an article in the IEEE Transactions on Software Engineering does a comparison of 5 theoretical models; TAM, TAM2, Perceived Characteristics of Innovating (PCI), Theory of Planned Behavior (TPB) and Model of Personal Computer Utilization (MPCU). Do we need to discuss these?

Figure 2.3: Theory of Reasoned Actions (TRA)

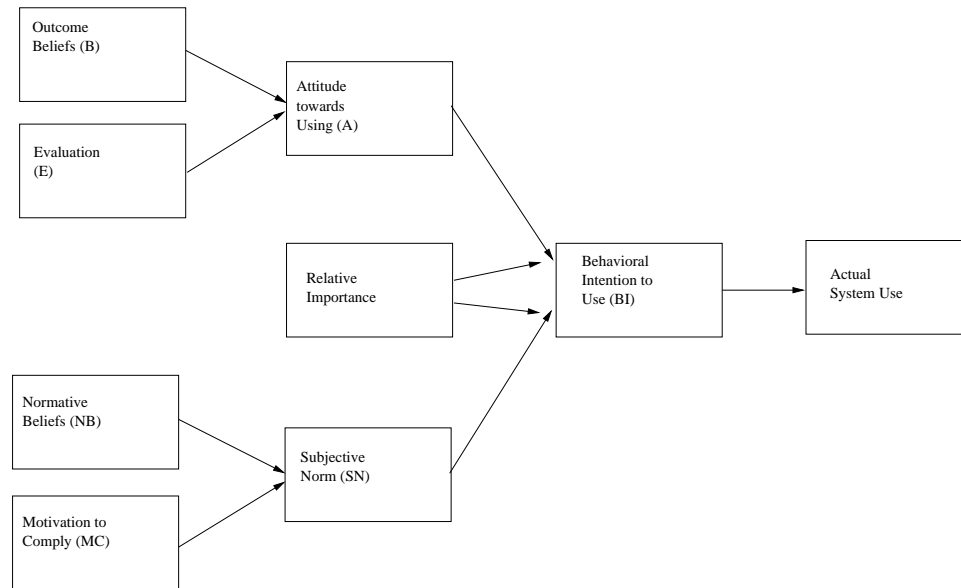

scribe the extent to which influential others' expectations impress upon an individual and Motivation to Comply is the extent to which the individual is willing to submit to those expectations.[48, 123]

Fred Davis [39] used the TRA as a foundation for the development of his Technology Acceptance Model (TAM), a model that has been widely used to explain user acceptance of computer technologies. The TAM adheres to the 'beliefs-attitude-intention-behavior causal relationship' that was developed in the TRA.[123] In this model, Perceived Ease of Use (PEU) and Perceived Usefulness (PU) of a computer technology are the crucial perceptions that lead to its ultimate adoption and usage.

Figure 2.4: Technology Acceptance Model

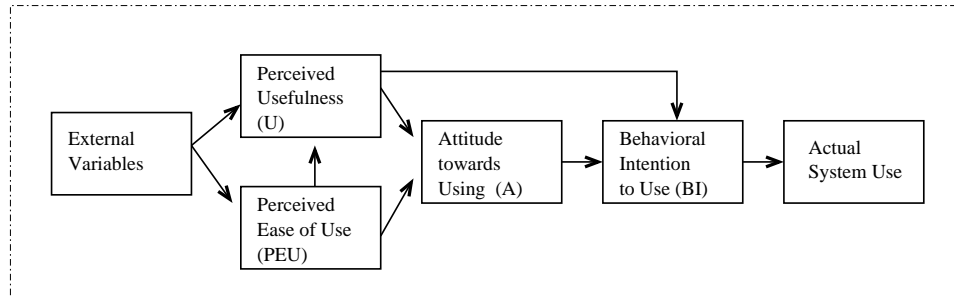

In the TAM, Perceived Ease of Use is defined as "...the degree to which a person believes that using a particular system would be free of effort." [39] Here Davis claims that given two equally capable systems, the system preferred by users will be that system which is perceived as being easier to use to accomplish the prescribed task. From a utilitarian perspective, systems that are low cost in terms of time and energy and fit within the boundaries of given constraints, are preferred to those which are unbounded or comparatively resource intensive.

Perceived Usefulness is defined as "...the degree to which a person believes that using a particular system would enhance his or her job performance." [39] By this Davis intends that a system perceived as having a high PU is one in which the intended user would find a correspondingly positive use-to-performance relationship. Users will accept systems that help them to perform better, and abandon those that will not.

Perceived Ease of Use is a determinant for Perceived Usefulness and both are determinants for Attitude Toward Using (A). Attitude Toward Using is defined as the degree to which the user finds desirable the usage of the specified computer technology. [123] It follows that positive perceptions of PEU and PU will lead to a corresponding positive attitude (A) to use the technology.

Behavioral Intention to Use (BI), the measure of likelihood that a user will actually

use the system, is influenced by the Attitude Toward Using and Perceived Ease of Use. Davis's BI is not the same as that of the TRA. The key difference being that subjective norm is subsumed in attitude (A) and in the evaluation of usefulness (PU) of the system and not seen as an independent determinant of BI. Interestingly, with dependence construed in fashion, there is the suggestion that even if a user holds a positive attitude toward using a system, if there is not also a positive perception that the usage of such a system is easy or provides a benefit then it is unlikely that the system will be accepted [123]. So it follows that Behavioral Intention to Use is the determinant of Actual System Use.

TAM has been validated in a number of contexts and successfully applied for predicting user acceptance of various (computer) technologies as evidenced throughout peer reviewed literature⁷. Yet, while TAM has good predictive strength, it does not completely explain user acceptance and that suggests significant factors may have been omitted from the original model.[96, 131, 82] Interestingly enough, Davis et al., foresaw the necessity to allow for variables external to the model to be incorporated and constructed TAM to be open-ended. That is, TAM has provision for the inclusion of External Variables that may act on either PEU or PU or both. Consequently, the power, extensibility, and simplicity of TAM make it an attractive model for the purposes of this study.

2.4.2 External Variables Related to e-Learning; An Extended Educational TAM

Given the fundamental reliance on technology that is inherent in e-learning, it follows that TAM could provide valuable insight into how students come to engage with e-learning technologies. Many factors that affect a student's ability to learn have been identified in brain research, psychology, and education research. Applying such characteristics as are known to affect student performance and learning for mastery to TAM would increase the

⁷A recent search on the "Web of Science" found 575 citations to Davis's 1989 article in the MIS Quarterly.

power of the model. Figure 2.5 illustrates an extended educational TAM. In it is synthesized a number of the student characteristics identified as influencing learning, especially e-learning. These characteristics would compose a student learner profile. Note, learning outcomes are not represented in this model. Learning outcomes as a product would follow adoption and system use. Learning outcomes as a measure of success would assume this entire model and be one measure of student performance and a test of the benefits of e-learning.

Figure 2.5: TAM Tested Factors

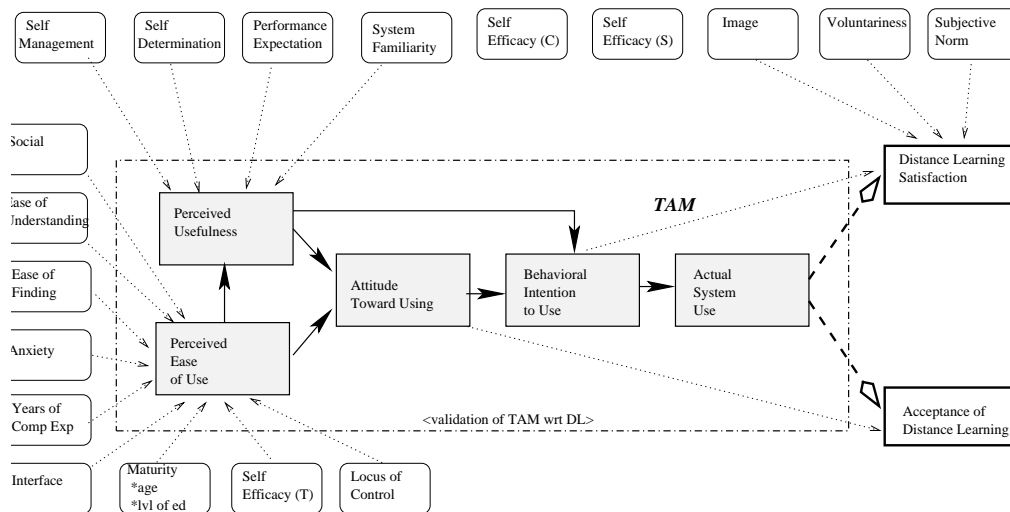

2.4.2.1 Self Efficacy

Self efficacy, the perception that one is capable or has the power to produce intended outcomes [8], has attracted considerable attention. Several studies have demonstrated

a positive relationship between computer self efficacy, Perceived Usefulness, and Perceived Ease of Use. For examples, see Hwang et al [78], Brosnan [16], Fenech [47], and McFarland [111]. Self efficacy has also been linked to student performance, but not satisfaction.[32]

However, Martins et al [108], Miller et al [116], Pan et al [132, 131] failed to show connections between self efficacy and either Perceived Ease of Use or Perceived Usefulness. Neither was self efficacy found to be connected to a student's intention to adopt e-learning, see Pajo [129]. Marakas et al [106] provides a review of the literature on computer self efficacy. In that work it was determined that self efficacy as a construct was poorly understood by researchers which, in turn, explains the contradictory results described above. A model of computer self efficacy was presented that clearly identified antecedent, consequent, and moderating factors with the suggestion that it be used as a foundation for future investigations.

It is interesting to note that self efficacy was originally dismissed by Davis et al [37] in the MIS Quarterly paper of 1989.

”(Bandura's)... self efficacy paradigm does not offer a general measure applicable to our purposes since efficacy beliefs are theorized to be situationally specific, with measures tailored to the domain under study.

...Self efficacy research does, however, provide one of several theoretical perspectives suggesting that perceived ease of use and perceived usefulness function as basic determinants of user behavior.” [37, p 321]

Self efficacy continues to be an attractive attribute upon which to postulate user success with online courses, even in light of the difficulties and highly individualized nature of this factor.

”Since self-efficacy is part of a self-regulatory system, the individuality of such characteristics can only be measured in specific academic domains. Recommendations are made for specificity in the constructs of empirical formulations to measure the predictive ability of the concept of self-efficacy. There has been

limited empirical investigations regarding the applicability of the concept of self-efficacy to online ...(course) retention. Nevertheless, the applicability of the concept to aid in the understanding of online learner characteristics cannot be discounted.” [79, page 9]

2.4.2.2 Computer Experience

Computer experience may be measured in degrees. Low experience has been connected to higher computer anxiety and shown to have a significant negative affect on Perceived Ease of Use and Perceived Usefulness, see Brosnan [16], Brown [17], and Peters [136]. At the other end of the spectrum, a link has been demonstrated between greater experience and perceived enjoyment each of which correspond with a positive affect upon Perceived Ease of Use and Perceived Usefulness; see Pajo [129], Hubona [76], Hwang [78], Nink [123], Njagi et al [124], and Hong et al [73]. Students who have demonstrated a high acceptance of the technology also performed better in class than their peers; Huang [75]. To help minimize the anxiety felt by novices and increase perceptions of usefulness three strategies are put forth. First, Brown [17] recommends simplifying the user interface and making navigation of the technology easy and user-friendly (i.e. work to positively influence a student’s perception of Perceived Ease of Use). The second strategy is to prepare students prior to taking e-learning courses with computer literacy training. It has been argued that increased familiarity with e-learning technology will work to assuage student anxieties, see Njagi et al [124], and Hong et al [73]. Finally, and by far the most common strategy, is to slow the pace of the course to accommodate the weaker skilled students. However, research suggests that if a course is slowed too much then experienced users lose interest and begin to take the technology (and the course) for granted. If the course is strongly polarized then neither group is adequately served by moving to some arbitrary middle ground. The consequence is that the overall performance of each group is negatively impacted; see Matthew et al [109], Morse [118], and O’Niel [126]. These results serve to reinforce the intuition

of classroom teachers noted earlier; i.e. to anticipate a connection between students who have grown up with information technologies at their fingertips and a higher performance in e-learning courses.

2.4.2.3 Social Influence Processes

Social influence manifests itself in two ways. The first is through external pressures put on an individual to use a technology, or in this case, to participate in an e-learning course. This form of social influence has received the most attention in MIS literature and has connections to the Technology Acceptance Model. The second form of social influence addresses the solitary nature of an e-learning course. The notion is that e-learning delivery and student participation often occur when the participant is alone, apart from distractions as well as other students. Education research has focused its attention on how students in an e-learning environment respond to perceptions of alienation and of relationships, both student to student and student to instructor.

Social Influence (MIS)

External pressures are captured in both the Theory of Reasoned Action and Technology Acceptance Model by Subjective Norm. Subjective Norm (SN) is the (perceived) degree of influence that the opinions and expectations of people in authoritative roles have upon the behavior of the individual in question. Teacher, professor, employer, parent, peer, and spouse would be examples of such people. SN is the degree to which one is willing to comply with the perceived pressure borne of a willingness to please, to build image, to meet obligations of perceived social contract, to bend to coercion (either implicit or explicit), or other means of persuasion.

Efforts to confirm the connection between SN and technology acceptance have yielded mixed results. Miller [117] did not find a connection between SN and amount of time

students spent on a computer in an online course (Usage). Pan [132, 131], on the other hand, did find that SN impacted students attitudes toward using technology (A) and consequently the grade in the course. Likewise, there is evidence that both peers and instructors play a significant role in fostering the acceptance of e-learning systems; see Collins et al [32], Martins [108] and Lee et al [95].

The lack of a clear connection between SN and technology acceptance has caused some researchers to re-examine the notion of SN. It has been suggested by some that SN, as it stands, confounds an understanding of the levels of psychological attachment that an individual may hold toward a particular behavior or attitude. That is, the process of social influence as captured by SN is too complex and may be divided into constituent processes; Malhotra et al [105].

”... [There are] three different processes of social influence that affect individual behavior:...

Compliance: when an individual adopts the induced behavior not because she believes in its content but with the expectation of gaining rewards or avoiding punishments.

Identification: when an individual accepts influence because she wants to establish or maintain a satisfying self-defining relationship to another person or group.

Internalization: when an individual accepts influence because it is congruent with her value system.” [105]

It is hypothesized that the level of psychological attachment, with internalization highest and compliance lowest, will affect the perceived fit that a technology has for an individual. The greater the perceived fit the greater the likelihood that a technology will be adopted for use on a long term basis, that is, used beyond the immediate, requisite application.

Social Influence (ED)

Social processes, taken for granted in a face-to-face learning environment [91], assume a new importance when constrained through *current* (read predominantly text-based) computer mediated media. Social presence theory, a subset of communication theory, is defined as "...the degree to which a person is perceived as "real" in mediated communication." [145, page 70] The degree of social presence perceived between a student, peers, and instructor is a predictor of perceived learning. It is also a determinant of satisfaction one has with the instructor; Richardson et al [145].

Immediacy may be defined as communication behaviors that reduce the perceived psychological distance between a student and instructor. Immediacy behaviors have been shown to be a significant predictor of satisfaction with web-based courses. The type and degree of interactions between students and instructor are as important as an instructor's behavior within a course; Jarbaugh et al [7].

At risk is the sense of community that is derived by close interaction and camaraderie generally experienced in a face-to-face environment; Cadieux [18]. While a strong perception of community does not necessarily translate into higher performance [18], the absence of a sense of community and peer interaction lead to feelings of alienation and loneliness with the result being low student satisfaction and rejection of the course (i. e. dropping out); Linden [101] and Peters [136].

Three sources of alienation have been identified; learning, peer, and course.[81] Students who feel learning and course alienation are reluctant to participate at any level, either face-to-face or online. Increased feelings of learning alienation within a student lead to decreased overall performance and satisfaction with an e-learning course; see Johnson.[81]

Peer alienation is problematic. On the one hand no direct link has been established to tie a student's performance with peer interaction.[81] However, there is strong sentiment

that student to student interaction has significant impact upon a student's perceptions of satisfaction; see Bork [14]. For example, consider students who exhibit inadequate technical skills and have increased levels of anxiety related to the class. Such anxieties debilitate students so that they cannot participate productively in the course (for example, weak typing skills in a chat room leaves a student out of an evolving conversation.) Technically savvy students will dominate the media, overrunning the weaker less skilled students. "Flaming", demeaning an individual online, is a persistent problem; Sproull et al [167] and Hara et al [66]. Experiences such as these cause students to reject involving themselves in future e-learning opportunities.

2.4.2.4 Culture

E-learning, as described thusfar, has an implied western work ethic and teaching paradigm ingrained. It is not neutral or value-free.[23] However, priorities and learning patterns vary from culture to culture. Perceptions of convenience, flexibility, and quality do not conform to established (western) metrics. This is especially true of cultures that have a strong identity with well defined religious and social hierarchies (e.g. China); see Chase et al [24], Chan [23], Hara et al [66], and Morse [118]. In addition, communication and listening styles are severely constrained in current e-learning instantiations. The consequence is that miscommunication, especially in e-learning classes with enrollment from diverse people groups, is highly likely.[23] The implication is that the notions of technology acceptance must be sensitive to cultural contexts.

Straub et al [171] found that individuals responses to TAM constructs varied significantly across three countries. The United States and Switzerland – in the usual mode of TAM – use PU as a predictor of usage. Japan, on the other hand, did not. The differences are related to Hofstede's [71] four cultural dimensions.

”These dimensions, used to distinguish between cultures, are:

- Power-distance – Degree of inequality among people, which the population of a culture considers normal;
- Uncertainty avoidance – Degree to which people in a culture feel uncomfortable with uncertainty and ambiguity;
- Individualism – Degree to which people in a culture prefer to act as individuals, rather than as members;
- Masculinity – Degree to which values like assertiveness, performance, success and competition prevail among people of a culture over gentler qualities like the quality of life, maintaining warm personal relationships, service, care for the weak, etc.” [17]

Brown [17] confirms that culture makes a significance difference for the application of TAM. Such is the case in African cultures where there is a shift away from PU to PEU as the main predictor. The inference is that TAM was created to model behaviors in developed countries; countries whose culture is *associative*, that is employing a strict cause-and-effect paradigm to create perceptions. Developing countries have cultures that are better described as *abstractive* and have a higher degree of uncertainty avoidance. Such countries/cultures would prefer simpler systems with more structure. Hence, PEU comes to the fore.[17]

2.4.2.5 Gender

Gender has been shown to correlate with how an individual engages in an e-learning course. In one study three barriers to participation were identified: 1) institutional, 2) situational, and 3) dispositional. Institutional barriers have to do with the usage and frustrations inherent in the technology. It was found that women vocalize greater frustrations with e-learning technology than do men. Situational barriers are those raised by external responsibilities apart from school. In general, women are much more likely to carry the dual role of primary care givers and bread winners for their families than men. As a result

those women express greater difficulty with time management for coursework than do men. Finally, dispositional barriers relate to attitudes and self-perceptions about the individual as a student. Males demonstrate greater confidence with the online learning environments than do women; Blum [13].

Males tend to be domineering, coarse, and abstract in their communications in e-learning courses. Females tend to be more interpersonal, relationship building, and more empathic in their communications. Females tend to be less certain about the e-learning technology than males.[13] With respect to acceptance, it has been determined that 1) PU has a more powerful influence upon intention to use computers for men than for women, 2) PEU has a more powerful influence upon intention to use computers for women than for men, and 3) women are more strongly influenced by SN than are men ; see Venkatesh et al [181], Yuen et al [196], Njagi et al [124], Peters [136], and Richardson et al [145].

2.4.2.6 Learning Style and Multiple Intelligences

Following the advances in manufacturing, educators adopted a mass production approach to educating children. Abandoning the one room schoolhouse paradigm with its interconnection of disciplines, small class size, and strong social bonds; education became industrialized. Math, science, social studies, art, literary arts, and physical education were taught separately, with different instructors, with little or no connection one to another. Class sizes grew larger, more impersonal, and instruction became a one size fits all treatment with the goal of churning out graduates by the multitudes. As the wealth of information exploded over the decades, educators felt justified in adopting a specialists approach to educating students. Yet even with all the growth and development within education, student achievement slumped.

Simply put, students do not all learn alike. One explanation that enjoys wide acceptance is Howard Gardner's Multiple Intelligences (1983). Gardner suggests that everyone has

nine distinct intelligences; visual-spatial, bodily-kinesthetic, musical, interpersonal, intrapersonal, linguistic, logical-mathematical, naturalist, and existentialist. According to Gardner each of us has a unique intelligence profile characterized by combinations of strengths and weaknesses in each of the intelligences.[59, 93] Recognizing these differences, providing educational opportunities that do not rely on any single intelligence, and assessing students through a variety of means is the prescribed method of improving student (distance learning) performance[93]. D. Sigurnjak [165] argues for an additional intelligence, emotional intelligence, to be included in the discussion of factors that impact student performance with respect to distance learning. Though this may be addressed through intra- and inter- personal intelligences.

Another very similar and equally popular approach to explaining the differences in how students learn is by ascribing them differentiated learning styles. David Kolb's Learning Style Inventory (1984), positions students along four learning scales; concrete experience (CE), reflective observation (RO), abstract conceptualization (AC), and active experimentation (AE) Kolb's Learning Styles⁸. Like a rectangular coordinate system, these scales divide space into four regions (see figure 2.6). An individual's (student's) characteristics are described in each region as follows:

- **Converger:** The converger is dominant in Abstract Conceptualization (AC) and Active Experimentation (AE). A converger relies on common sense, prefers things to people, may be emotionally detached, and is seen as a pragmatist. This individual has a narrow field of interest, employs deductive reasoning to solve problems, and prefers the practical application of ideas over theory. [168]
- **Diverger:** A diverger is the opposite of the converger and is dominant in Concrete Experience (CE) and Reflective Observation (RO). A diverger is highly imaginative

⁸See <http://www.usd.edu/~ssanto/kolb.html>

Figure 2.6: Learning Styles

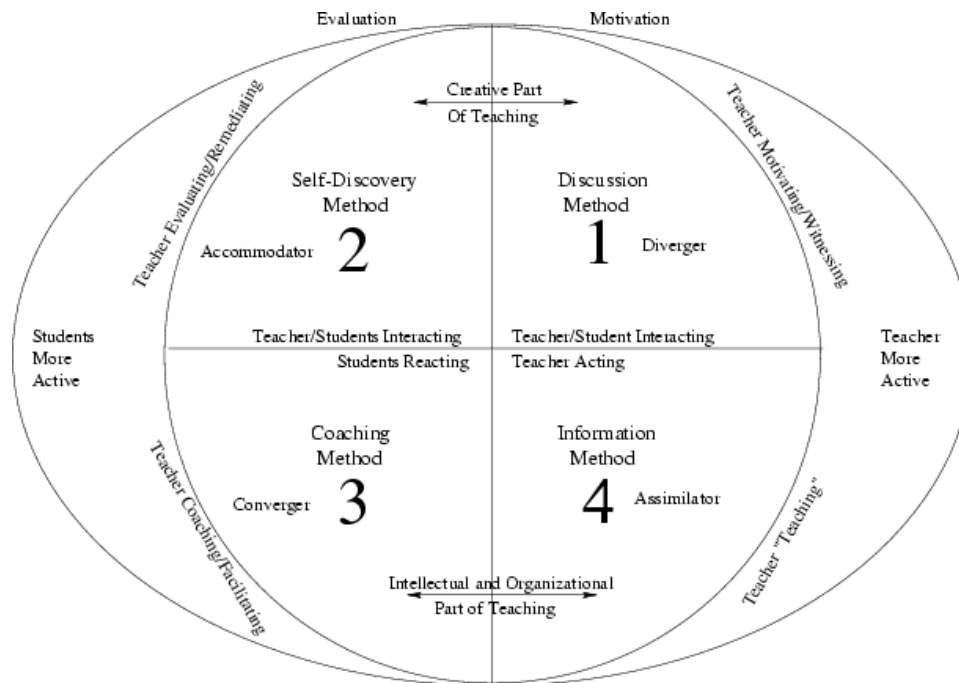

and able to view a problem from multiple perspectives. This individual has broad interests, is emotionally involved, and is disposed toward the arts. Such an individual is adept at generating ideas, especially through techniques such as brainstorming.[168]

- **Assimilator:** An assimilator's strengths are Abstract Conceptualization (AC) and Reflective Observation (RO). An assimilator reasons well inductively, can weave disparate observations into theory, and is less concerned with the concrete application of ideas. This individual prefers logic to emotion. [168]
- **Accommodator:** An accomodator is the opposite of the assimilator. The dominant learning styles are Concrete Experience (CE) and Active Experimentation (AE). This individual is a "doer", willing to take risks, solves problems by trial-and-error, seeks out new experiences, and is able to adapt to new situations quickly.[168]

Several studies have been done that examine the link between learning style, perfor-

mance, and e-learning satisfaction. Students with strong visually oriented learning styles have been found to be more effective and have a greater satisfaction with e-learning than their peers.[9, 133] How an individual perceives and orders information has also been linked to e-learning. Perceptual ability, either concrete or abstract, is how information is internalized. Ordering, sequential or random, is how an individual organizes information. There is a connection between sequential learning styles and a preference for computer based instruction over face-to-face instruction, with sequential learners spending more time online and having greater overall satisfaction with e-learning than random learners.[97] Each study also notes a significant difference between genders in preferred learning styles and the impact upon student achievement.[13, 88, 97]

None of these studies connected learning style or multiple intelligences to either TAM or TRA. Small sample sizes also cast some doubt as to the extensibility of the results.[97] Much of this research stems from the education side of e-learning, it may prove useful to examine these concepts from an MIS perspective.

2.4.2.7 Intrinsic Motivations

Intrinsic motivations are defined as those belonging to the student and not dependent on external circumstances. Intrinsic motivation is a complex concept. It has not been distilled to any single (student) characteristic. Studies that examine intrinsic motivations have grouped into this category personal innovativeness, risk seeking/risk avoidance, enjoyment, age, level of education, uncertainty avoidance, autonomy, self-reliance, individualism, meta-cognition, self concept, self monitoring, motivation, strategy formation, and volition control strategies.[76, 78, 123, 136, 103, 88, 129, 180] Each has been demonstrated to have a net positive influence on technology acceptance. Enjoyment also has a positive influence on self-efficacy, time on task, and the satisfaction associated with the usage of a given technology.[78, 129, 180] Age and level of education have been linked to

usage amount, while level of education influences attitude to use.[76] Belief formation has been linked to an individual's behavioral intention to use (BI) and ultimately technology acceptance.[123]

2.4.2.8 Extrinsic Motivations

Extrinsic motivations are those that occur external to the student and have to do with the technology and perceptions of the advantages associated with its usage. A number of characteristics fall into this category. Job relevance, output quality, and demonstrable results have been shown to have significant connections to user acceptance; Venkatesh [180]. Relative advantage and compatibility, the degree to which a system is conformed to performing a given task, were shown to significantly influence an individual's belief in the usability of a system. Compatibility also significantly influenced usage; see Al-Gahtani et al [4]. Finally, communications between learners and frequent, timely, relevant feedback both in terms of self-reflection vis-a-vis previous experience, or with peers and mentors has been inextricably linked to the fostering positive attitudes toward acceptance of e-learning.[75, 195]

2.4.2.9 Acceptance

B. Daley et al [36], set out to determine the effect of technology on student learning and how thinking behaviors evolve through usage. Daley's overarching framework was based on Marzano and Pickering's (1997) five dimensions of learning:

- Dimension 1: Attitudes and Perceptions – with respect to school, subject, and perceived ability; influences learning either positively or negatively (DIM1)
- Dimension 2: Acquire and Integrate Knowledge – use existing knowledge base to understand new information; to be able to recall the new knowledge with accuracy

(DIM2)

- Dimension 3: Extend and Refine Knowledge – reconciling new information with existing worldview (DIM3)
- Dimension 4: Use Knowledge Meaningfully – apply the new knowledge to solve authentic problems and make decisions (DIM4)
- Dimension 5: Habits of Mind – incorporating new knowledge into one’s problem solving skills for improved accuracy and efficiency (DIM5) [174]

In this model attitude and habits of mind are considered the backdrop against which the other dimensions play out. In addition, each dimension is intimately connected with every other dimension so that each is being acted upon concurrently as opposed to sequentially.

In her study, Daley found that students with a negative attitude participated less often and were more likely to be frustrated by the shortcomings of the technology (DIM1). These students were able to acquire knowledge but were unable or unwilling to redesign or re-frame this knowledge into something meaningful (DIM2). Furthermore, this group of students did not develop or extend their knowledge (DIM3), neither were they successful at applying the new information (DIM4). Since this group had not cultivated the new knowledge they were unable to add any new habits of mind to their skill sets (DIM5).[36]

Students with a positive or hesitant attitude toward the technology participated more often (than their negative counterparts) and found the exercises challenging, fun, and exciting (DIM1). Students were able to acquire and assimilate the new information (DIM2). These students were successful at extending and refining their understanding of the new information (DIM3). They were able to apply the new knowledge to solve complex problems (DIM4). Students in this group learned to apply the new information and to think more

Figure 2.7: Daley on DOL in e-learning

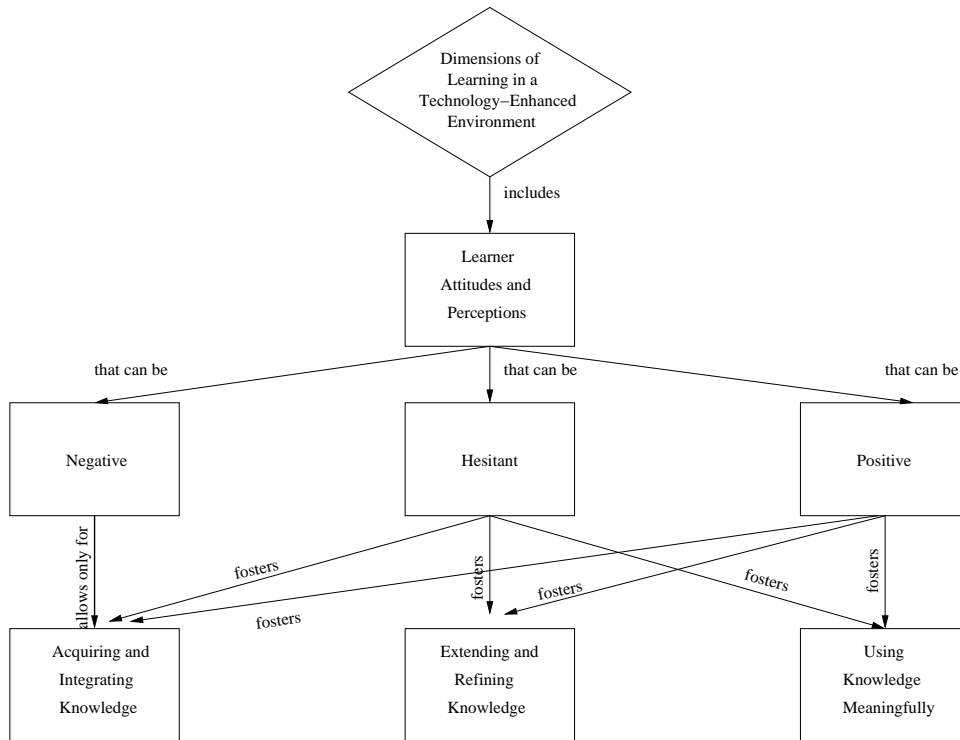

critically (DIM5).[36] Figure 2.7[36, p 133] shows the connections found between attitude and dimensions 2, 3, and 4.

This study identifies technology acceptance and subjective norm as *the* key factors for predicting student achievement in an e-learning environment. Moreover, Daley identifies these factors as the "lens" through which the learning process must be focused.

"Findings from this study indicate that participant learning is strongly influenced by technology and other dimensions of the learning experience. It was clear from the data that the participant learning was influenced by individual attitudes and perceptions of technology, learning tasks, peers, and facilitators. These factors appeared to be the lens through which participants acquired,

integrated, and used meaningfully the knowledge constructed in the learning process... It appears that these perceptions and attitudes influenced how learners constructed their knowledge base in a technology-enhanced environment.” [36, p 130]

K. Hong [73, 72] corroborates Daley’s conclusions. A negative attitude diminishes participation, collaboration, and fosters negative beliefs about the technology. Such students become invisible, doing only what is necessary and waiting until the last minute to complete a task. Their performance is dismal. Hesitant students are on a cusp and need to be identified and guided. If hesitant students become overwhelmed, stranded, or otherwise disenfranchised with respect to the technology they could slip into the negative group. Students with positive attitudes contribute to the class, accept challenges, meet course goals, and perform well.

Njagi[124], on the other hand, did not find evidence of significant changes in attitude for students using web based learning versus those participating in traditional face-to-face classes. However, Njagi was looking for attitude change and started with a nearly homogeneous group of students positively aligned with the technology. Furthermore, Njagi reports difficulty in accurately measuring attitude.

2.4.3 Summary

To understand how students interact with e-learning technology in our simplified learning framework two avenues of research have been explored. Research from an MIS approach yields the Technology Acceptance Model. TAM has proven fruitful for understanding how individuals come to terms with essential (e-learning) technologies. Appendix D Table 4.1 gives a listing of relevant factors linked to TAM. However, learner characteristics that were chosen were done so independent of an education framework and miss some key educational concepts. This condition may be due to the fact that the original TAM was focused on large computer technology driven corporations with an emphasis on MIS issues

of process and productivity, not on education or training.[37, 168]

Education research presents a more learner-centered, learner-focused approach to understanding e-learning. See Appendix D Table 4.3 for a complete list of factors taken from this research. Two factors that appear most often in this sampling of the literature are the importance of communication and of technical ability. Timely, relevant communication helps to reduce perceived social distance and creates a sense of community. Students who are adept at using the technology experience fewer frustrations. They have the freedom to focus wholly on learning the material instead of struggling to learn both interface and content.

One approach taken in the education research has been to substitute learner satisfaction for acceptance and content mastery. However, Fritzsche[53] found that students perceived learning does not necessarily correlate with actual learning performance measures (except in the extremes, i.e. doing extremely well or extremely poorly.) Fritzsche's findings cast a shadow over the usefulness of this factor as a predictor of student success. Moreover, education research does not adequately address students' attitude, perception of usefulness, or intention to use the technology (TAM.) It is a serious omission according to Daley, "...the importance of the students attitudes and perceptions of the technology is paramount. How students perceive the technology will impact their learning." [36, p 136] A comprehensive understanding of how students engage e-learning must therefore pull from both MIS and education research.

2.5 Assessment

Assessment may be of two types, either norm referenced or criterion referenced. In norm referenced testing the level of performance is measured against a group or population. Norm referenced testing is appropriate for measuring the range of abilities of a group. It is not appropriate for measuring affective or psycho-motor objectives. Criterion referenced

testing is ideal for measuring mastery of objectives, including affective and psycho-motor. It is also useful to determine if students have the prerequisite skills for a particular lesson or course, and for grouping students.[192]

Assessment may be further divided into two groups formative and summative. Formative testing occurs before and during instruction[192]. Formative assessment is often termed "assessment for learning". It is used to provide feedback to students and as a means of determining whether to proceed; to remediation/review, to move forward, to jump ahead, and/or to provide enrichment. It is this kind of testing and flexible learning that is advocated by Carchiolo et al [21], and Roberts[147]. Summative testing, referred to as "assessment of learning", is used at the end of instruction. It is used to determine the final level of student performance attained.[192]

Actual implementation of testing may take one of three forms, either objective testing, essay testing, or performance testing. Objective testing includes multiple-choice, true/false, short answer, and fill-in. Objective tests are not open to interpretation, either the answer is correct or it is not.[192] This type of test is easily implemented in e-learning but provides the least information about what was learned. Adaptive testing addresses this shortfall. Adaptive testing is a form of objective testing that calculates scores on the fly and constantly revises the number and the level of difficulty of the remaining question(s). This is done in order to give students the greatest opportunity to demonstrate their mastery of the material.

Essay testing presents students with a topic or problem for which they must devise a solution. Essay testing includes case studies, portfolio, journaling, simulations, proofs, and essay questions.[192] With essay testing students are engaged at a number of cognitive levels in preparing their answer, hence this type of format provides the richest means for assessing learning.[119] Essay testing is ideally suited for e-learning. The flexibility of time inherent in e-learning provides students an opportunity to prepare their thoughts offline before submitting their entry.[94] However, essay testing is the most difficult test format to

grade and harder still to automate.[183] Clearly established rubrics and holistic scoring are useful tools for helping to grade this type of exam.

Performance testing is accomplished most readily with electronic journals and e-portfolios .[26, 43] Using e-portfolios, students collect artifacts that exhibit their understanding and/or acquisition of skills. Through the collection and building process it is possible for peers and instructors to make constructive criticisms of the work in progress, that is, assessment for learning. Final e-portfolios are polished and presented for evaluation, an assessment of learning. E-porfolios have the added benefit of being useful beyond the e-course to illustrate to interested others skills garnered from the experience.

A negative aspect of online assessment, one that has become all too common, is the problem of cheating. Cheating seems to be much more prevalent with the advent of the web[170, 179]. McMurtry[112] has coined the phrase e-cheating to capture this phenomenon. E-cheating ranges from plagiarism [152, 187] (downloading reports et cetera) through to substitute test takers (exploiting the anonymous nature of e-learning.) T. Jones [84] explores the mechanics of giving assessments at a distance. He has made several suggestions for those considering adopting distance learning assessment;

1. Students should take the exam at the same time (as much as is possible) and in one sitting.
2. Exam questions should be pulled from a sufficiently large pool as to avoid the possibility of any two students have identical exams.
3. Instructions for taking exams and progressing through them must be clearly stated.
Note: In some cases where returning to previous exam questions is not allowed, students must be made aware of this feature.

4. Students should have the flexibility of taking the exam online or via some other accommodation, without penalty.

As with all such assessment instruments validity, reliability, and bias must be addressed[192].

2.6 Feedback

Feedback from the instructor is considered a crucial aspect of learning, and no less so for e-learning. Timely feedback fosters a perception of social presence and immediacy within a student. High social presence helps to overcome feelings of alienation and aloneness. It increases a student's overall satisfaction with an e-learning course.[145]

One use of feedback is as an indicator of student progress. Flexible learning and tutoring systems assess student progress frequently, conform themselves to the student, and provide just-in-time remediation or enrichment as needed. The learning paths such systems deliver are uniquely determined by the needs, strengths, and weaknesses of the individual; see Bork [14] and Carchiolo et al [22].

Leveraging the asynchronous nature of e-learning provides a unique opportunity to build a student's skills. Spending time offline composing one's thoughts can give rise to prose that is much more insightful and meaningful than the kind of discourse that occurs in a chat room, for example. Writing as a reflective process with pertinent feedback builds a sense of community for an online course. As above, improved sense of community or social presence is expected to provide an increased level of student satisfaction and perceived learning; Lapadat [94].

Feedback from peers can become a sticking point for an online course. Some students feel that addressing correspondence to their peers is safer, less vulnerable, than posting to a larger audience or to their instructor.[73] The fear of looking foolish, especially in a written form that has a persistence, is greatest in those with little or no previous experience using computer mediated instruction. However, demeaning responses from peers can have

a devastating effect on the flow of communication and perceived value of an online course; Blum [13] and Schierling [154].

Finally, frequent feedback between instructor and students is an integral component of e-learning and necessary if one is to assuage the feelings of frustration and anger that arise from students' misgivings about what an online course can and cannot provide. Online courses are not a panacea and require a great deal of commitment to be a success. Many students and teachers find that online courses are markedly more labor intensive than traditional face-to-face courses; Leonard [2].

2.7 Summary

The works examined serve to expand the simple learning system postulated at the beginning of this chapter (figure 2.1). Much has been written on this topic, and while this collection is in no way exhaustive, it is representative of the breadth and scope of research in this field. More importantly, the simple learning system defines a framework for the ensuing research and identifies the major elements that are critical to successful e-learning systems.

A theme that runs throughout the literature is the flexibility that e-learning technologies (learning management systems) provide. Flexibility has two primary components, time and content. Flexibility with respect to time provides latitude of when to connect, and also gives students an opportunity to reflect on what was learned before having to respond to a query. An unhurried, thoughtful response to chats and discussion questions has been demonstrated to provide for a richer discourse from which all e-learning participants benefit.

Flexibility with respect to content is probably the greatest strength of e-learning systems. Flexible learning systems give students the freedom to diverge from the core lesson(s) for remediation, re-teaching, review, exploration, and/or enrichment. Students may revisit and/or explore material as often as they care, with no disdain from either peers or

instructor. Flexible e-learning systems, like those described, have the potential to evolve into what amounts to personally tailored tutoring systems.

However, before students can exercise the flexibility of an e-learning system, they must learn to navigate and adopt it. The literature is filled with anecdotes that underscore the importance of experience and prerequisite skills needed to use an e-learning system. Students with skills flourish. Students without skills become casualties, often either dropping the course or failing outright.

It is interesting to note where the literature diverges, especially with respect to the tack taken by MIS versus that of pure education. MIS appears to have a more mechanistic, process oriented focus. Key MIS factors are perceived usability, usability, behavioral intent to use, subjective norm, self efficacy, and attitude (see Table 4.1). Education takes a more humanistic approach. Key education factors are gender, learning style, social communication, feedback, and multicultural background (see Table 4.3).

The German philosopher, Georg Wilhelm Friedrich Hegel set forth a system of dialectic motion. In that system one puts forth an argument (a thesis), it is subject to a counter-argument (an antithesis), both are reconciled by synthesis. The synthesis becomes the new thesis and the process repeats. In this case MIS's thesis of a mechanistic, technology driven e-learning must be resolved against education's humanistic one (antithesis), with the two brought together to form a comprehensive understanding of the factors at play in e-learning (a synthesis).

What is lacking in the literature is a cohesive model that captures the relevant factors of both MIS and education's approach to an understanding of e-learning. Fortunately, an examination of the education landscape does provide for some support. C. A. Tomlinson's⁹

⁹Various repositories for differentiated instruction;
<http://k12.albemarle.org/Technology/DI/>
<http://members.shaw.ca/priscillatheroux/differentiatinglinks.html>
http://www.frsd.k12.nj.us/rfmslibrarylab/di/differentiated_instruction.htm

differentiated learning model [177] accommodates many, if not all, of the factors identified by both MIS and education research . What's more, differentiated instruction is postulated on the concept that each learner brings with him a unique set of strengths and weaknesses (a learner profile). Differentiated instruction meets the students where they are by leveraging ability, respecting limitations, and tailoring instruction appropriately.[64] Differentiated instruction engages students with real world problems, encourages knowledge discovery, and is active rather than passive. Differentiated instruction favors mastery and comprehension rather than content coverage.

Differentiated instruction's focus on a student's learning profile brings into sharp focus the importance of the works cited above. Those studies examined factors that contribute to the success of a student in an e-learning environment. Differentiated instruction would build upon those factors and further emphasize the need to provide for customizable e-learning environments. Hence, differentiated instruction in this context is tantamount to flexible e-learning.

Figure 2.8 illustrates the interaction between key elements of an e-learning system. While it may seem obvious, it must be reiterated that technology is central to e-learning. Yet this does not imply a greater significance than the other elements. Rather it suggests that any model that intends to identify critical factors of e-learning must also address the interaction with technology. Hence, differentiated instruction alone is not sufficient to capture adoption issues pertinent to e-learning, neither is the TAM, or learning objects, or instructional model, or pedagogy taken in isolation. All must be woven together to build a comprehensive e-learning theory.

<http://www.gp.k12.mi.us/ci/diff/resources.htm>

Figure 2.8: Effective e-learning[28]

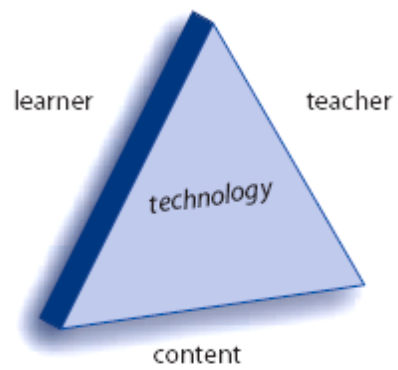

Effective instructional technology mediates relationships among learners, teachers, and training content.

CHAPTER III

METHODOLOGY

3.1 Research Question

Center stage in the minds of educators is the need to improve student performance. Educators are convinced that in order to accomplish this goal it is incumbent upon them to provide each student customized learning experiences that are authentic and relevant while meeting state mandated standards. Failing is not an option; the future of our country and economy hinges upon the success of every instructor reaching every student. No child shall be left behind.

It is widely held that students learn at different rates, differ in what they find meaningful, are molded by their varied backgrounds, possess a range of mentalities, and hence have different capacities for learning. Educators' own experiences reinforce these beliefs. Many theories exist to decipher how students think and learn. A popular theory adopted by educators is Howard Gardner's theory of Multiple Intelligences (MI) described in his *Frames of Mind*[58]. For many educators, measures of MI have supplanted the single measure of general intelligence (IQ)[121] as predictors of student academic success. Consequently, over the last two decades Gardner's theory has become a basis for development of instructional methodologies.

Coupled with the notion that students' uniquenesses require customized instruction is the belief that all students can learn (all things). Such a belief presupposes that students

desire and are willing to learn what is being presented, that there are sufficient resources to accommodate them, and that time will be used flexibly to accommodate students' varied learning rates. Ideally, each student would have individualized instruction and tutelage for as long as needed in order to learn the required material. However, in a traditional class with rigid content requirements and a fixed timeline, it is rarely possible to realize all goals for all students. Consequently some students "fall through the cracks". One way to overcome this dilemma is through the use of e-learning. E-learning systems have the potential for becoming the ideal personalized tutor. E-learning systems are used for course enhancement, credit recovery, and to extend education opportunities to both traditional and nontraditional students that might not otherwise be available.

However, can an automated e-learning system be tailored to accommodate *every* student's unique learning profile?[149] It has already been reported that the drop out rate for e-learning courses is higher than for traditional face-to-face courses.[27, 107, 49] It follows that there may be a disconnect or mismatch between how some students prefer to learn and what an e-learning management system can (currently) provide. Given the importance and value placed on student achievement on the one hand, and the ineluctable trend toward and investment in e-learning management systems on the other, it behooves us to consider what constitutes a good fit between an individual student and an e-learning system . Hence the research question becomes "*what is the relationship, if any, between a student's MI profile and his/her acceptance of e-learning technologies?*"

3.2 Hypotheses

Davis's Technology Acceptance Model (TAM)[39] provides a well accepted method for ascertaining the likelihood of acceptance and adoption of a technology by a group of users. Furthermore, the TAM has already been used to explore factors related to education (see Chapter 2) and so has an established credibility within this domain. By design, the TAM

is extensible, allowing for the addition of external factors which may influence the initial conditions of Perceived Ease of Use (PEU) and Perceived Usefulness (PU) .[111] In the current context, it follows that whether or not students will accept e-learning technologies will be determined by their perceptions of the usefulness and usability of such systems. Perceptions of usefulness and usability will be strongly influenced by how students prefer to learn. Learning preferences, in turn, are related to a student’s mental capacities which may be estimated by capacities of MI as defined by Gardner (see Figure 3.1).

Figure 3.1: Multiple Intelligences vis-a-vis TAM

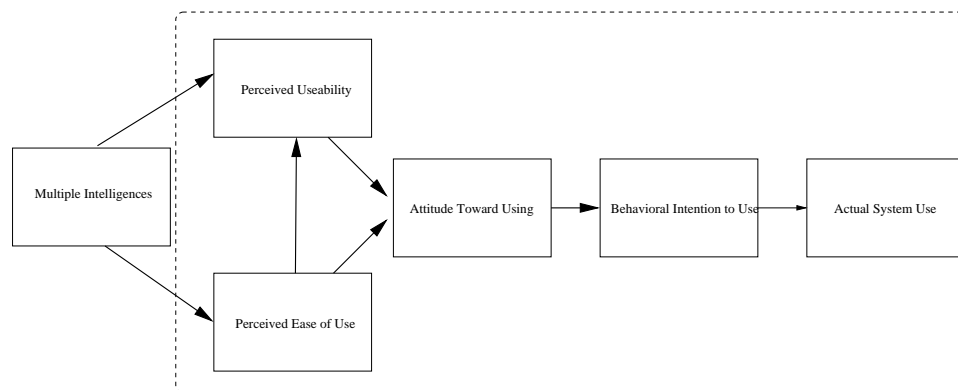

Gardner defines intelligence as “*an ability to solve problems and create products that are valued by at least one culture*” [58, 55]. He goes on to establish criteria for determining what constitutes an intelligence, as follows.

1. Each intelligence can be isolated by brain damage.
2. Each intelligence is evidenced in exceptional people (i.e. savants and/or prodigies).
3. Each intelligence has an identifiable core set of operations or mechanisms.

4. Each intelligence has a process of development during childhood and has a peak end-state performance.
5. Each intelligence has a plausible history of evolution.
6. Each intelligence is evidenced in experimental psychology.
7. Each intelligence has support from psychometric findings.
8. Each intelligence can be expressed by its own unique set of symbols.
9. Each intelligence is apparent in species other than humans.
10. Each intelligence has been tested using multiple measures, some of which are not associated with intelligence.
11. Each intelligence can work independent from any of the others ¹.

Using these criteria, Gardner identified eight multiple intelligences with a ninth, existential intelligence, currently under investigation.[55] The eight MI are verbal/linguistic, musical, kinesthetic, visual/spatial, logical/mathematical, interpersonal, intrapersonal, and naturalist. Table 3.1 identifies portions of the brain that each of the MI have been associated with. The eight MI will comprise the set of independent variables for this study and are defined as follows.

¹http://www.orangeusd.k12.ca.us/yorba/multiple_intelligences.htm

Table 3.1: Neurological Systems vis-a-vie MI

Multiple Intelligence	Associated neurological system
Kinesthetic	Cerebral motor strip, thalamus, basal ganglia, cerebellum
Musical	Right anterior temporal and frontal lobes
Spatial	Right hemisphere, parietal, posterior
Logical-Mathematical	Left parietal lobes, adjacent temporal, occipital association areas for logic & math; left hemisphere for verbal naming; right hemisphere for spatial organizations; frontal systems for planning & goal setting
Linguistic	Left hemisphere, temporal & frontal lobes
Personal Intelligences	Frontal lobes as integrating station between internal and external states

Verbal/Linguistic Intelligence (VL) implies a command of language, its syntax, phonology, semantics, and pragmatics. Examples would include storytellers, poets, politicians, and persons who craft language to effectively communicate through either the spoken or

written word. This intelligence is expressed through an ability to use rhetoric to persuade, mnemonics to recall, explanation to inform, and/or meta-language to talk about the language itself .

Logical/Mathematical Intelligence (LM) is the ability to reason well, think logically, and to discern patterns. Scientists, mathematicians, accountants, and statisticians exemplify this intelligence. Individuals with a strength in this intelligence possess the ability to understand and manipulate formalisms, propositions, classifications, and generalizations.

The ability to visualize and manipulate mental images is referred to as Visual/Spatial Intelligence (VS). It is a visual acuity; a keen sensitivity to color, line, form, space, and the relationships that exist between these elements. Hunters, scouts, decorators, architects, artists, and sculptors who perceive the world accurately, have the capacity to transform those perceptions, and graphically present them serve to illustrate this intelligence.

A person equipped with a keen perception and understanding of musical pitch, timbre, and rhythm is said to possess a high degree of Musical/Rhythmic Intelligence (MR). Such an individual would possess the capacity to recognize, compose, discriminate, transform, and/or express musical compositions. Composers, performers, music critics are typical of people who possess a high musical/rhythmic intelligence.

Athletes, dancers, surgeons, mechanics, and sculptors are generally thought of as having a degree of agility, dexterity, strength, flexibility, and/or speed. These traits are associated with the Bodily/Kinesthetic Intelligence (BK) and are exemplified by a high degree of control over one's own body.

Interpersonal Intelligence (IE) connotes a high degree of empathy and the capacity to interface well with others. An individual gifted in this intelligence picks up on subtle cues of voice, expression, gestures, and motivations of others. It is said of these individuals that they possess the ability to read people.

Intrapersonal Intelligence (IA) is inwardly focused. It describes an individual's capacity

for meta-cognition. A person who is cognizant of his or her own strengths, limitations, moods, temperaments, desires, and moreover, is able to act upon that knowledge is said to have a high degree of intrapersonal intelligence.

Being able to comprehend, recognize, and classify objects in the surrounding environment are characteristic of the Naturalist Intelligence (NL). Sensitivity to natural phenomena related to weather, geography, finding direction, and discriminating between inanimate objects are crucial survival skills. This intelligence is equally relevant in the wilds as in urban settings [163, 55].

It is important to pause and draw a distinction between multiple intelligences and another popular classification scheme; learning styles. Broadly speaking, learning styles are a means to describe differential preferences and responses of an individual to a learning environment. Many models have been extended to describe learning styles. Most lack a firm foundation in educational psychology and are rife with controversy². Learning styles are often mistakenly used synonymously with multiple intelligences. While learning styles may be loosely coupled with multiple intelligences, they differ in a significant way. Specifically, multiple intelligences speak to one's abilities and what one can do, while learning styles focus on one's preferences. Neither are multiple intelligences the same as interests. Multiple intelligences are a much more fundamental notion, addressing one's capacities. Those capacities, in turn, provide the foundation upon which to shape one's individuality. Table 3.2, prepared by Shearer [163], describes how each of the eight intelligences are made manifest in one's disposition.

²<http://www.lsda.org.uk/files/PDF/1543.pdf>

Table 3.2: Multiple Intelligences in Everyday Life[163]

	Activities	Suggested Study Skills	Just for Fun	for School Major	Careers
Musical	singing, listening, playing instruments, concerts	rhyme, rhythm, repetition, song, create lyrics	hum, sing, drum, rhyme, compose	band, vocal, composing, choral	choral director, musician, music teacher, sound engineer, D.J.
Kines- thetic	sports, dance, handi- crafts, walking, running, exercise	gestures, write it large 3 times, act out, dramatize it, build a model	wrestle, touch football, soccer, magic tricks, juggle, dance	recreation, dance, leisure, fitness, physical ed, therapy	actor, as- sembler, coach, laborer, choreog- rapher, aero bics, surgeon
Linguistic	speaking, reading, writing, story telling, poetry	note taking, checklist, outline, tape recording, teach	word play, poetry, story telling, lyrics reading aloud	journalism, education, sociology, literature	writer, editor, librarian, teacher, transla- tor, sales, public relations
Logical Mathe- matical	calculating, investiga- tion, problem solving, logic	question, count, categorize, explain, analyze, compare, explore	chess, mysteries, challenges, puzzles, computers	engineering, accounting, medicine, computers	lawyer, chemist, analyst, book- keeper, engineer

Continued on next page

	Activities	Suggested Study Skills	Just Fun	For	School Major	Careers
Spatial	map reading, artistic design, crafts, mechanical	watch, visualize, sketch, colorize, cartoon, metaphors	doodling, photography, model making, clothing design		architecture, engineering, aviation, graphic design	landscape design, artist, interior design, pilot
Inter-personal	empathy, managing, getting along with others	study groups, teach to someone, discuss it	team games, sports, sharing, helping others, volunteering		ministry, public relations, management, nursing	teacher, nurse, counselor, secretary, politician, sales
Intra-personal	personal knowledge, opinions, self direction	test yourself, why is it important to me, what do I already know about it	reflection time, questionnaires, talking about oneself, journals		creative writing, philosophy, psychology, leadership	minister, psychologist, writer, artist, engineer, counselor
Naturalist	understanding animals, working with plants	use your senses to observe and make distinctions	raise a pet, walk in the woods, plant flowers		biology, ecological studies, horticulture	naturalist, forester, farmer, botanist, greenhouse

Table 3.2 suggests that one's behaviors are inextricably linked to one's unique mix of multiple intelligences. Implicit in this connection is that the greatest satisfaction is had by an individual when one's vocation coincides with one's MI profile.[160] Furthermore, it is apparent that individuals, given the opportunity, self sort career and education paths based on innate abilities, i.e. multiple intelligences. That is, ability determines what one sees as

natural (a good fit) and what, in turn, is incongruous (a stretch) to one’s nature.

Self-sorting/self-selection is voiced by students when qualitatively describing a course or material as being “easy”, “useful”, “hard”, or “irrelevant”. Educators are cognizant of this self selection process (i.e. students “tune in” or “tune out”) and work to match their instructional methods with student capacities and student preferences. Students self select majors, electives, even instructors based, at least in part, on their inherent abilities and aptitudes. It follows that elearning courses go through a similar filter, and would be selected as suitable based on compatibility with one’s abilities, abilities which are extensions of one’s unique multiple intelligence profile.

Davis’s Technology Acceptance Model (TAM) positions Perceived Ease of Use (PEU) and Perceived Usefulness (PU) of a technology as the inroads to understanding the likely adoption of that technology. Extending TAM to elearning suggests that PEU and PU may similarly serve as determiners of whether students would be willing to adopt elearning technologies. Davis’s model makes allowances for external influences that may affect either of these two key variables. This research posits multiple intelligences as likely external variables that significantly shape a student’s perceptions of ease of use (PEU) and usefulness (PU) specifically as related to elearning (see equations 3.1 and 3.2).

$$\begin{aligned}
 \textit{PerceivedUsefulness}_{elearning} &= \mathfrak{F}(\textit{MultipleIntelligences}) \\
 &= \mathfrak{F}(VL, LM, VS, MR, BK, IE, IA, NL) \quad (3.1)
 \end{aligned}$$

$$\begin{aligned}
 \textit{PerceivedEaseOfUse}_{elearning} &= \mathfrak{G}(\textit{MultipleIntelligences}) \\
 &= \mathfrak{G}(VL, LM, FS, MR, BK, IE, IA, NL) \quad (3.2)
 \end{aligned}$$

Figure 3.2 illustrates the connections that arise from the equations 3.1 and 3.2 and the portion of the TAM that will be tested with respect to e-learning. The following hypotheses

Figure 3.2: Hypotheses of the MI Extended TAM

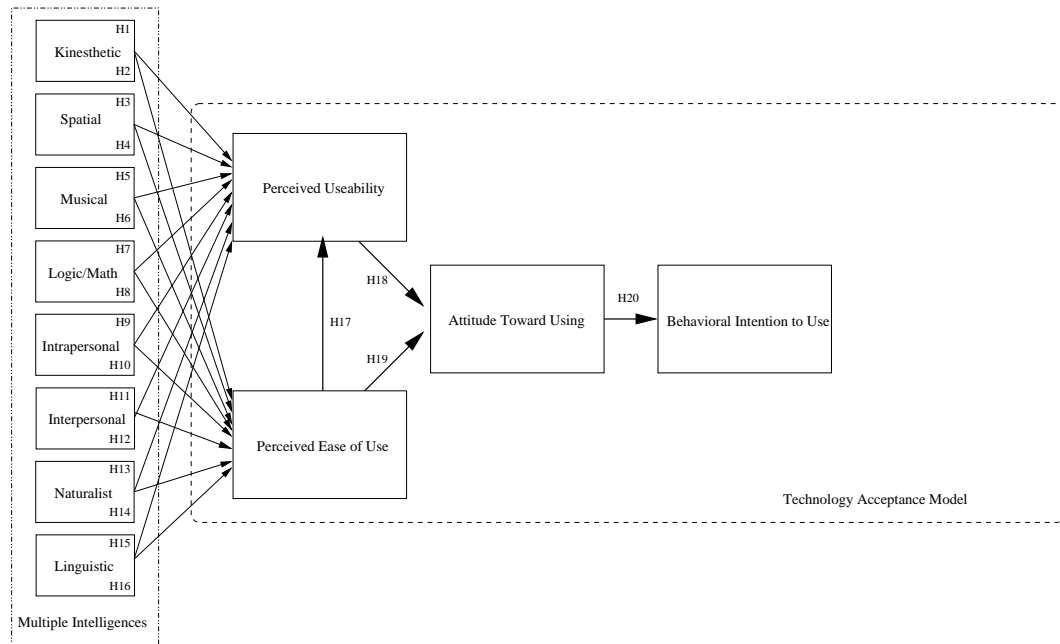

will be investigated.

HYPOTHESIS 1: There is a negative relationship between bodily/kinesthetic (BK) intelligence and the perceived usefulness (PU) of an e-learning system. [92].

HYPOTHESIS 2: There is a negative relationship between bodily/kinesthetic (BK) intelligence and the perception that an e-learning system is easy to use (PEU). [92].

HYPOTHESIS 3: There is a positive relationship between visual/spatial (VS) intelligence and the perceived usefulness (PU) of an e-learning system.[92].

HYPOTHESIS 4: There is a positive relationship between visual/spatial (VS) intelligence and the perception that an e-learning management system is easy to use (PEU). [92].

HYPOTHESIS 5: There is a negative relationship between musical/rhythmic (MR) intelligence and the perceived usefulness (PU) of an e-learning management system.[92].

HYPOTHESIS 6: There is a negative relationship between musical/rhythmic (MR) intelligence and the perception that an e-learning system is easy to use (PEU). [92].

HYPOTHESIS 7: There is a positive relationship between logical/mathematical (LM) intelligence and the perceived usefulness (PU) of an e-learning management system. [92].

HYPOTHESIS 8: There is a positive relationship between logical/mathematical (LM) intelligence and the perception that an e-learning management system is easy to use (PEU). [92].

HYPOTHESIS 9: There is a positive relationship between intrapersonal (IA) intelligence and the perceived usefulness (PU) of an e-learning management system. [92].

HYPOTHESIS 10: There is a positive relationship between intrapersonal (IA) intelligence and the perception that an e-learning management system is easy to use (PEU). [92].

HYPOTHESIS 11: There is a negative relationship between interpersonal (IE) intelligence and the perceived usefulness (PU) of an e-learning management system. [92].

HYPOTHESIS 12: There is a negative relationship between interpersonal (IE) intelligence and the perception that an e-learning management system is easy to use (PEU). [92].

HYPOTHESIS 13: There is a negative relationship between naturalist (NL) intelligence and the perceived usefulness (PU) of an e-learning management system. [92].

HYPOTHESIS 14: There is a negative relationship between naturalist (NL) intelligence and the perception that an e-learning management system is easy to use (PEU). [92].

HYPOTHESIS 15: There is a positive relationship between verbal/linguistic (VL) intelligence and the perceived usefulness (PU) of an e-learning management system. [92].

HYPOTHESIS 16: There is a positive relationship between verbal/linguistic (VL) intelligence and the perception that an e-learning management system is easy to use (PEU). [92].

HYPOTHESIS 17: There is a positive relationship between the perceived ease of use (PEU) of an e-learning management system and its usefulness (PU). [38, 47, 105]

HYPOTHESIS 18: There is a positive relationship between the perceived usefulness (PU) of an e-learning management system and the attitude (ATU) to use such a system. [38, 47, 105]

HYPOTHESIS 19: There is a positive relationship between the perceived ease of use (PEU) of an e-learning management system and the attitude (ATU) to use such a system. [38, 47, 105]

HYPOTHESIS 20: There is a positive relationship between the attitude (ATU) to use an e-learning management system and the behavioral intention (BI) to use such a system. [38, 47, 105]

In each case the null hypothesis is that there is no relationship between the independent variable and the dependent variable named.

3.3 Research Design

To test the relevance of multiple intelligences to student acceptance of an Internet elearning technology a survey research methodology was employed. The goal of this methodology is to test hypotheses about a population and may be characterized by the degree to which it, 1) generates quantitative data about a population, 2) employs well defined structured questions, and 3) utilizes statistical analyses upon a suitable sampling of the population under investigation.[139] Such a study is done in situ, measures phenomena over which the researcher does not exert control (except as to length and time of the study), and concerns itself with a model of relationships between clearly defined independent and dependent variables and the generalizability of findings about the model to a target population as a whole.[139, 194]

The research plan began with the selection of suitable validated survey instruments to use in a cross-sectional field survey conducted at a northern Ohio area high school. The school has divided itself into 5 subsets, one of these subsets was chosen at random and the entire population was surveyed. Empirical data was collected in two phases so as to cause the least amount of disturbance and distraction of the typical school day. Ordinary least squares regression (OLS) analysis was employed to validate causal relationships between each of the 8 major multiple intelligences and the technology acceptance model's antecedent variables of use and usability. OLS was further used to confirm the relationships of usefulness, usability, and attitude proposed by Davis's technology acceptance model. Each of these steps are detailed in the following sections.

3.3.1 Sample

The high school, an inner ring suburban school of 1833 students[125], is a college preparatory school with a diverse multicultural student population. Academically it pro-

vides a wide range of classes from the technical preparatory in which students may earn industry accepted certifications in areas such as pharmacology and computer networking, through advanced courses in mathematics, science, social studies, and English. The high school is rated by the state as being “Effective”, a condition which is based upon the school’s ongoing performance in student achievement testing, attendance, and graduation rate. Specifically, the school has met 9 of 12 state indicators for success, having achieved or surpassed the state’s required performance levels in Reading, Writing, Social Studies, Mathematics, and Graduation Rate, but missing the mark in the areas of Science, and Attendance Rate (2007)[125]. The school is deemed a good representative of urban high schools across the state, sharing many of the same successes and challenges as other high schools. The school has recently undergone a significant restructuring and divided itself into 5 subsets called “small schools” with the intent to give a more personalized education to their adolescent students to address the shortcomings cited above. One of these smaller schools was chosen for this study.

The school district to which this high school belongs, has recently adopted an elearning software tool called Moodle. Moodle is an open source course management system (CMS) used to provide an on-line classroom experience (elearning). Moodle’s functionality is compared favorably with commercial CMS elearning products (see Appendix C) used throughout the world. Moodle itself is used world wide with 35,000 registered sites in 199 countries. In addition, the website (MOODLE WEBSITE <http://moodle.org>) reports usage statistics citing 2,256,434 courses with 24,039,289 users and 1,099,770 teachers and an enrollment of 13,199,769. Moodle is under continuous development and shows strong growth and acceptance in the education and training communities. This school district has made Moodle available to its teachers and students. Professional development is ongoing to train teachers in the use and administration of this elearning software. Teachers from elementary, middle, and high school have experimented with using Moodle to support blended

learning environments. However, consistent regular use of the software district-wide has not yet occurred. As a result, most students in the district have a very limited, if any, experience with Moodle. An ancillary benefit of this research is to extend the awareness of elearning to more students in the district. Moodle provides a more than adequate platform for framing the discussion of elearning with the subjects of this study.

3.3.2 Survey Instruments

Two instruments were used to capture the empirical data for this study. One instrument was used to assess a student's perceptions about elearning technology and a second to assess his/her preferred mode of learning. Each instrument and all supporting documents were reviewed by both the university and the school district selected. Permissions to conduct the study were obtained from both.

Prior to receiving any of the instruments, students were given documents describing the study, the value of the work, and what they might expect to learn if they participated fully in the process. Teachers were also given supplemental information on the multiple intelligences instrument so as to better inform their students about the nature and value of the assessment instrument. Both instruments were administered in the course of a normal school day in a traditional classroom setting and were viewed as typical of the work expected of high school students.

3.3.2.1 TAM Survey

Perceptions concerning new technologies are often assessed using a variant of the Technology Acceptance Model (TAM) survey originally used by Davis. Perceptions are generally captured via survey but may also be done by interview. The TAM is generally administered to people using or testing a new technology like the elearning content management system Moodle. Likert scaled, the TAM is used to assess Perceived Ease of Use, Per-

ceived Usefulness, Attitude Toward Using, Behavioral Intention to Use, and Actual Usage of a system or technology. For this research, 40 questions demonstrated to have high explanatory power (highly significant p-values) were selected from several studies, including Davis's original work. Questions were edited only to focus on elearning and the use of the elearning software Moodle. It is assumed, for this study, that the population of interest has little practical experience with elearning systems. Hence, actual system usage was not measured. A seven-point Likert scale was chosen for the TAM items. A sample of the survey is included in APPENDIX I. In addition to the 40 TAM questions, another 10 questions were asked to assess the level of involvement students have with technology, and the level of comfort they have in its uses, academic or otherwise.

3.3.2.2 Multiple Intelligences Developmental Assessment Scales

The Multiple Intelligences Developmental Assessment Scales (MIDAS) is a screening instrument designed to give a "reasonable estimate"[161, p18] of an individual's multiple intelligences. However, it is not an absolute measure of ability, nor are multiple intelligence scores construed to be fixed but may vary in time. The MIDAS instrument may be administered as either a questionnaire or an interview, or may be otherwise completed on the behalf of another.

The MIDAS has gone through extensive development and has been tested for both reliability and validity through multiple independent studies. Studies of internal consistency (items within scales), temporal stability (test-retest comparisons), and inter-rater reliability (agreement between rater's responses) all report reliability (Cronbach's alpha) scores that average over 0.80. Independent factor analysis has shown loadings of each of the 119 items queried align with the eight multiple intelligence scales, confirming construct validity. Correlation studies of the MIDAS scales with comparable standardized aptitude, cognitive and achievement tests have demonstrated strong concurrent validity. Finally, two university

studies comparing instructor's assessments of students and students self-assessments have shown strong predictive validity. Details of each of these studies may be found in the MIDAS Professional Manual, prepared by B. Shearer [161].

The MIDAS uses a five-point Likert scale and does not force an answer to an item, but allows for the respondent to answer "Does not Know" or "Does not apply" as needed. The questions have been written objectively with the intention of capturing observable performance, frequency of involvement, and/or enthusiasm about relevant activities [161]. The MIDAS manual suggests that respondents be given 30 to 50 minutes to complete the assessment. Participating teachers were encouraged to plan for one 50 minute class period to administer the self-reporting questionnaire and to allow anyone who needed more time to be granted it. All students were able to complete the instrument in the allotted time.

3.3.3 Data Collection

Data collection was conducted in two phases over a three week span. In phase one, students were asked to complete the MIDAS. 332 students took the MIDAS assessment. Upon completion of all phases of the data collection and scoring, students received a confidential personalized report of their MIDAS scores (see Appendix H for a sample profile). Teachers were encouraged to talk with students willing to share their scores about particular strengths and/or weaknesses and the implications of the same. Teachers were given a slide presentation expounding upon multiple intelligences to help with the process.

The second phase of the study consisted of a visit to sixteen participating classrooms. Each visit was comprised of a short slide show and video presentation on the nature and uses of elearning technologies and a followup Technology Acceptance Model (TAM) survey. The presentation focused on the elearning technology adopted by the school district and served as an introduction to its usage at the high school. Twenty-five minutes were allocated for the presentation and another twenty-five minutes were set aside for completing

the TAM. These times proved more than adequate and students did not appear to be unduly hurried to complete the survey instrument. 269 students completed the TAM survey.

Seventeen mathematics classes had originally been identified for the study. These classes ranged from introductory algebra, geometry, through pre-calculus courses and had a mix of ninth through twelfth grade students with varying levels of math ability, see Table 3.3. Halfway through the process one teacher opted out (Geometry class). This decision reduced the number of complete student subject cases by 25. The study was conducted in the same span of time as the school was administering its mandatory 10th grade state graduation exam. There was some concern that students would be suffering from “test fatigue” and be reluctant to take more paper-and-pencil assessments. However, this did not turn out to be the case. Most students seemed to welcome the two interruptions to traditional classroom instruction and were receptive to the presentations. One group was particularly interested in receiving their MIDAS scores back again to see where their abilities lay. No other intervening events were observed, that is, there were no holidays, outings, or other school related activities that would impinge upon the data collection process. Students were asked to complete their surveys independent of their peers and without interaction. Hence, the data is assumed to be random, independent, and free from systematic errors.

Merging the results of the two surveys yielded a workable sample size of 212 cases (a 64% response rate)[166]³. 120 cases of either the TAM or MIDAS were discarded for various reasons including incompleteness, students being absent and only completing one or the other of the instruments, students responding in only one column without varying or otherwise sabotaging a survey instrument, et cetera. These were obvious errors, readily identified. To discover other univariate outliers the outer fence rule⁴

³A sample size of 169 would be sufficient for this study. See Soper, D.S. (2009) “The Free Statistics Calculators Website”, Online Software, Daniel Soper’s Sample Size Calculator <http://www.danielsoper.com/statkb/topic01.aspx>

⁴After dividing the data set into 4 quartiles, calculate the interquartile range (IQR) by

Table 3.3: Classes Surveyed

Course of Study	Number of Students Enrolled	Number of Classes
Geometry	43	2
Algebra 1st Year	53	4
Algebra 2nd Year	78	3
Math Topics	81	3
Pre-Calculus	38	2
Algebra 2nd Year, Honors	26	1
Pre-Calculus, Honors	22	1
TOTALS	341	16

One Geometry class was removed with 25 students. The total reflects student enrollment, the actual number of students present varies day by day.

($3 \times \text{InterQuartileRange}$) was applied to the agglomerated TAM and MIDAS data (i.e. summed PEU, PU, reported MIs, et cetera). No other univariate outliers were detected nor removed from either data set at this stage.

Tables 3.4, 3.5, and 3.6 give a break down of student subjects involved in the study by gender, race, and grade level. The data shows a roughly even distribution of males and females and grade levels. The Table 3.7 shows that approximately 74% of the students surveyed had not previously used an elearning system with another 22% having only limited experience with such systems (1 or 2 previous on-line classes). This last observation is in alignment what was originally suspected about the low level of actual elearning usage that this population would exhibit.

taking the difference of the 25th (Q1) and 75th (Q2) percentiles. The lower outer fence is given by $Q1-3IQ$, and the upper outer fence by $Q2+3IQ$. Points beyond these limits are considered extreme outliers. See NIST Specifications <http://www.itl.nist.gov/div898/handbook/prc/section1/prc16.htm>

Table 3.4: Demographic: Gender Composition [142]

Gender	Frequency	Percentage
Male	99	46.7%
Female	113	53.3%
TOTAL	212	100.0%

Males and females are equally distributed, $\chi^2(df = 1, n = 2) = 0.9245, (p = 0.9245) > 0.05$

Table 3.5: Demographic: Racial Composition [142]

Race	Survey Frequency	Survey Percentage	School Population by Percentage for 2008-2009
Black	144	67.92%	80.2%
White	56	26.42%	15.1%
Other	12	5.66%	4.7%
TOTAL	212	100.00%	100.0%

The sample distribution does not follow the district racial composition reported to the state, $\chi^2(df = 2, n = 3) = 22.3745, (p = 1.385e - 5) < 0.05$

3.3.4 Data Analysis Methods

To validate the model the following strategy has been employed, 1) calculated correlation coefficients to determine whether there was a relationship to pursue, 2) examined the scatter plots of the data to determine if a linear relation was warranted, 3) calculated (multiple) regression statistics, 4) pruned the model as necessary to handle outliers, 5) tested regression assumptions, 6) adjusted the model, where possible, to align with the assumptions and reran the regression.

Table 3.6: Demographic: Grade Level Composition [142]

Grade Level	Frequency	Percentage
9 th grade Freshmen	46	21.70%
10 th grade Sophomores	57	26.89%
11 th grade Juniors	58	27.36%
12 th grade Seniors	51	24.05%
TOTAL	212	100.00%

Grade Levels are equally distributed, $\chi^2(df = 3, n = 4) = 1.7736, (p = 0.6207) > 0.05$

Table 3.7: Previous Experience with eLearning [190]

Response	Frequency	Relative Frequency	Cumulative Frequency
N.A.	4	1.89%	1.89%
0	156	73.58%	75.47%
1-2	46	21.70%	97.17%
3-4	3	1.42%	98.58%
5-6	2	0.94%	99.53%
7 or more	1	0.47%	100.00%

3.3.4.1 Regression Assumptions

The objective of ordinary least squares regression analysis is: 1) to establish whether or not there exists a relationship between variables, 2) to determine the nature of that relationship in terms of a mathematical model, 3) to assess the quality of the model, and 4) for multiple regression, to establish the relative importance of the predictor variables [85]. As such, OLS is a suitable means for confirming or denying the existence of the relationships set forth in the hypotheses stated above.

In order to correctly apply OLS to the data certain criteria must be met. The Sage handbook of Applied Regression [98] gives the following list of assumptions for a regression.

“For the population, the bivariate regression model is,

$$Y_i = \alpha + \beta X_i + \varepsilon_i$$

where the Greek letters indicate it is the population equation, and we have included the subscript, i , which refers to the i^{th} observation. With the sample, we calculate

$$Y_i = a + bX_i + e_i$$

In order to infer accurately the true population values, α and β , from these sample values, a and b , we make the following assumptions.

The Regression Assumptions

1. No specification error.
 - a) The relationship between X_i and Y_i is linear.
 - b) No relevant independent variables have been excluded.
 - c) No irrelevant independent variable have been included.
2. No measurement error.

- a) The variables X_i and Y_i are accurately measured.
3. The following assumptions concern the error term, ε_i :
- a) Zero mean $E(\varepsilon_i) = 0$.
 - i. For each observation, the *expected value* of the error term is zero. (We use the symbol $E()$ for expected value which, for a random variable, is simply equal to its mean.)
 - b) homoskedasticity: $E(\varepsilon_i^2) = \sigma^2$. (a constant)
 - i. The variance of the error term is constant for all values of X_i .
 - c) no autocorrelation: $E(\varepsilon_i \varepsilon_j) = 0$ ($i \neq j$).
 - i. The error terms are uncorrelated.
 - d) The independent variable is uncorrelated with the error term: $E(\varepsilon_i X_i) = 0$.
 - e) Normality.
 - i. The error term, ε_i , is normally distributed.” [98, page 26]

The first assumption asks whether the linear functional form (as opposed to polynomial, logistic, et cetera) selected for the regression is the correct one, that it is without omission, and complete. Specification error will lead to erroneous estimates of the regression parameters and be evident as systematic patterned errors in residual plots [68, 67]. Including more variables than are necessary is termed “over-fit” of the data, while perhaps not negatively impacting the model or coefficient of determination, they may lead to unnecessarily large uncertainties in model parameters [68, 67].

Data must be collected so as not to introduce any bias. Measurement error of the dependent variable may not be as deleterious as error in the independent variable. If the error on the dependent variable is random then it may yet be possible to obtain an unbiased least

squares estimate. However, if the error is on the independent variable(s) then the least square estimates will be biased and corrupt the model [98]. This assumption is difficult to test for and will necessarily depend upon the design of the study.

That the mean of the error terms is zero may be assessed by plotting the residuals and determining if they are equally scattered about the horizontal line at 0 (termed a 'null plot'). This assumption aids in the analysis of other characteristics of the regression. Violation of this assumption will bias the intercept estimate, but leave the slope (beta) estimate(s) unaltered [98]. For this research the intercept is considered inconsequential.

A major assumption of regression is that the data is equally dispersed about the regression line, that is homoskedastic. This assumption is more easily assessed by considering the variability of the residuals. If the residuals show unusual patterns in their plots then the data may be heteroskedastic. Heteroskedasticity is a result of skewness of one or more of the independent variables. A consequence of this violation is that the regression equation will be better at modeling some levels of the independent variables than at others. Moreover, this error in the variance of the coefficient estimates will result in incorrectly identifying which coefficients are to be rejected or accepted (see Table 3.8). Hence, when heteroskedasticity is present, inferences about the regression line are suspect and steps need to be taken to correct the problem if possible (e.g. with the use of weighted least squares regression).[63, 98, 193]

The autocorrelation assumption asserts that there is to be no correlation between an error of one observation with errors of any of the other observations. If this assumption is violated the impact is not upon the parameter estimates but on the significance tests and confidence intervals, which it invalidates. That is, there will be a tendency to incorrectly identify coefficients as statistically significant [98, 11]. This assumption is an issue more often with time-series variables and will not be considered for this study.

Testing that independent variables are uncorrelated with error terms is examined under

Table 3.8: Consequences of Heteroskedasticity

Standard error b appears too...	Absolute T is too...	p-value is too...	Maximum confidence level is too...	We are more likely to erroneously _____ as significant
high	low	high	low	reject
low	high	low	high	accept

This table is given in a pdf located at <http://www.lsu.edu/faculty/bratton/7963/hetero.pdf>

the 'problem of endogeneity'. Endogeneity is the case in which the variables that as supposed to determine an outcome are themselves dependent upon the choice of outcome. If this happens then the least squares parameter estimates are biased. For this study there is no reason to suspect the problem of endogeneity exists [98]⁵. However, to complete the analysis of independence, plots of the residuals of the regression were examined for patterns or other departures from the null plot.

Normality is a fundamental assumption of both the dependent and independent variables, and provides the basis for the methods and tests applied in performing a least squares regression. While regression is robust with regard to deviation from normality, if the deviation from normality is too large then the use of F and t statistics becomes invalid. Multivariate normality is difficult to confirm but easier to refute. Specifically, if the variables do not have a univariate normal distribution then neither will they exhibit a multivariate normal distribution (note, however, that univariate normality does not necessarily imply multivariate normality).[63] Once again the residuals are tested to confirm that the assumption is upheld.

⁵See also <http://www.answers.com/topic/endogeneity>

3.3.4.2 Linear Relationship

A formal test for linear functional form may be conducted with RESET, Ramsey Regression Equation Specification Error Test (1969). The null hypothesis for RESET is that the linear model choice is adequate, the alternate is that it is not. To test the hypotheses several regressions are performed and an F-statistic calculated, as follows.

“Consider the model

$$y_i = \beta_1 + \beta_2 x_{i2} + \beta_3 x_{i3} + e_i$$

and the hypothesis

$$H_0 : E [y|x_{i2}, x_{i3}] = \beta_1 + \beta_2 x_{i2} + \beta_3 x_{i3}$$

$$H_1 : \text{not } H_0$$

Rejection of H_0 implies that the functional form is not supported by the data.

To test this, first estimate y_i using least squares and save the predicted values, \hat{y}_i . Then square and cube \hat{y} and add them back to the model as show below:

$$y_i = \beta_1 + \beta_2 x_{i2} + \beta_3 x_{i3} + \gamma_1 \hat{y}_i^2 + e_i$$

$$y_i = \beta_1 + \beta_2 x_{i2} + \beta_3 x_{i3} + \gamma_1 \hat{y}_i^2 + \gamma_2 \hat{y}_i^3 + e_i$$

The null hypotheses to test (against alternative, 'not H_0 ') are:

$$H_0 : \gamma_1 = 0$$

$$H_0 : \gamma_1 = \gamma_2 = 0$$

Estimate the auxiliary models using least squares and test the significance of the parameters of the \hat{y} 's"[3, p. 86]

3.3.4.3 Outliers

Outliers and other influential points are described as values that have the potential of substantially altering the regression line. They arise from four possible sources: 1) error in observation or data entry, 2) an explainable extraordinary observation, 3) an unexplainable extraordinary observation, 4) an extraordinary mix of ordinary observations [63]. How these values are handled must be decided on an item-by-item basis. For purposes of this study, highly influential observations were dropped, keeping in mind that students have no vested interest in this work, nor are they receiving any course credit for their participation, neither was it possible to interview each student to discover their particular rationale for answering as they did. Therefore, it was assumed that students became bored with or otherwise became disinterested in completing the surveys fully and honestly. This position is in alignment with the observations made by the proctor who administered the TAM survey.

One method used to determine which points are influential is to calculate the leverage of each value [113]. This may be done using the diagonal of the hat matrix as follows:

$$\hat{y}_i = h_1y_1 + h_2y_2 + h_3y_3 + \cdots + h_iy_i + \cdots + h_ny_n, i = 1, 2, \dots, n$$

“where the weights h_1, h_2, \dots, h_n of the observed values are functions of the independent variables. In particular, the coefficient h_i measures the influence of the observed value y_i on its own predicted value \hat{y}_i . This value, h_i , is called the leverage of the i th observation.”[63, p388]

Influential values are then compared with the average leverage value of all n cases which is given by the following [113]:

$$\bar{h} = \frac{k + 1}{n} = \frac{\text{Number of } \beta \text{ parameters in the model, including } \beta_0}{n}$$

Values that exert undue leverage on the model are those that exceed twice the average leverage value, \bar{h} [113], that is, values that fit the rule:

$$h_i > \frac{2(k+1)}{n} = 2\bar{h} \quad (3.3)$$

3.3.4.4 Test for Homogeneity of Variance

The test for homogeneity of variance of the residuals is calculated using White's Test. White's test is a general method to test the null hypothesis $H_0 : \sigma_i^2 = \sigma^2$, the residuals are homoskedastic, against the alternative that the variances are not equal, heteroskedastic. The test is performed by evaluating a regression of squared residuals against the independent variables, their squares, and all of the crossproducts[3]. The coefficient of determination of this regression is used to calculate an LM statistic as:

$$LM = n * R^2$$

The LM statistic has a chi-square distribution and is tested accordingly[3].

If White's test rejects homoskedasticity then it becomes necessary to correct for the error. One solution to this problem is to perform a weighted least squares regression, with more importance (weight) given to observations with higher fidelity (less variance) and lesser weight to observations with lower fidelity (high variance).

“Suppose that the errors vary proportionally with x_i according to

$$Var(e_i) = \sigma^2 x_i$$

The errors are heteroskedastic since each error will have a different variance, the value of which depends on the level of x_i . Weighted least squares reweights the observations in the model so that each transformed observation has the same variance as all the others. Simple algebra reveals that

$$\frac{1}{\sqrt{x_i}} Var(e_i) = \sigma^2$$

So, multiply equation (8.1) by $1/\sqrt{x_i}$ to complete the transformation. The transformed model is homoskedastic and the least squares standard errors are statistically valid and efficient.” [3, pages 106-108]

The equation referenced as (8.1) is as follows:

$$y_i = \beta_1 + \beta_2 x_{i2} + \dots + \beta_k x_{iK} + e_i \quad i = 1, 2, \dots, T$$

where y_i is the dependent variable, x_{ik} is the i^{th} observation on the k^{th} independent variable, $k = 2, 3, \dots, K$, e_i is random error, and $\beta_1, \beta_2, \dots, \beta_K$ are parameters you want to estimate.” [3, page 103]

3.3.4.5 Criteria for Selecting Between Competing Models

Several measures may be used for model selection and include the Akaike Information Criterion (AIC), the Schwarz Information Criterion (BIC), and the Hannan-Quinn Criterion (HQC). These measures make use of the maximum likelihood estimates together with the number of cases and independent variables to calculate their values. See Table 3.9 for specifics about these statistics. For each measure of AIC, BIC, and HQC the lower the value the better the model.

Table 3.9: Information Criteria Used for Model Selection

Measure	Formulation	Parameters	Synopsis
Akaike's Information Criterion (AIC)	$2k - 2\ln(L)$	k =number of parameters estimated L =maximum likelihood estimate	lower AIC is better model, tends to bias toward large number of parameters
Hannan-Quinn Information Criterion (HQC)	$2 * \ln(L) + 2k \cdot \ln(\ln(n))$	L =maximum likelihood estimate n =size of dataset k =number of parameters estimated	balances goodness of fit and complexity, smaller HQC values indicate better model
Schwarz Criterion (SBC), also Bayesian Information Criterion (BIC)	$-2 \cdot \ln(L) + k \cdot \ln(n)$	L =maximum likelihood estimate n = size of dataset k =number parameters estimated	penalizes additional parameters (complexity) more than AIC, lower BIC implies fewer explanatory variables and/or a better fit of the model

(see [http://en.wikipedia.org/wiki/\[33\]](http://en.wikipedia.org/wiki/[33]))

CHAPTER IV

FINDINGS AND DISCUSSION

The theory of Multiple Intelligences is one way educators endeavour to understand what drives students to 'tune in' or 'tune out' of what is occurring in the classroom. It is asserted that matching activities and lessons to a student's preferred mode of learning is one way to recapture a student's interest and engage him\her in the learning process [162, 161]. It seems a natural extension to suggest that just as multiple intelligences influence how one prefers to learn (e.g. one often hears "I am not a visual learner, I am more hands on" et cetera), that that preference may, in turn, drive how one perceives a learning technology as either useful or easy to use. That conjecture gives rise to the multiple intelligence extended technology acceptance model reproduced in Figure 4.1 and the hypotheses given in Table 4.1. However, as appealing as the notion may be, it is not supported in this research. The 212 students surveyed, overwhelmingly accepted the concept of elearning independent of their multiple intelligence profile. The results are detailed in the following discussion.

Table 4.1: Hypotheses Outcomes

Hypothesis	Result
1 There is a negative relationship between bodily/kinesthetic (BK) intelligence and the perceived usefulness (PU) of an e-learning system.	Not Supported

Table 4.1: Hypotheses Outcomes

Hypothesis	Result
2 There is a negative relationship between bodily/kinesthetic (BK) intelligence and the perception that an e-learning system is easy to use (PEU).	Not Supported
3 There is a positive relationship between visual/spatial (VS) intelligence and the perceived usefulness (PU) of an e-learning system.	Not Supported
4 There is a positive relationship between visual/spatial (VS) intelligence and the perception that an e-learning management system is easy to use (PEU).	Not Supported
5 There is a negative relationship between musical/rhythmic (MR) intelligence and the perceived usefulness (PU) of an e-learning management system.	Not Supported
6 There is a negative relationship between musical/rhythmic (MR) intelligence and the perception that an e-learning system is easy to use (PEU).	Not Supported
7 There is a positive relationship between logical/mathematical (LM) intelligence and the perceived usefulness (PU) of an e-learning management system.	Not Supported

Table 4.1: Hypotheses Outcomes

Hypothesis	Result
8 There is a positive relationship between logical/mathematical (LM) intelligence and the perception that an e-learning management system is easy to use (PEU).	Not Supported
9 There is a positive relationship between intrapersonal (IA) intelligence and the perceived usefulness (PU) of an e-learning management system.	Not Supported
10 There is a positive relationship between intrapersonal (IA) intelligence and the perception that an e-learning management system is easy to use (PEU).	Not Supported
11 There is a negative relationship between interpersonal (IE) intelligence and the perceived usefulness (PU) of an e-learning management system.	Not Supported
12 There is a negative relationship between interpersonal (IE) intelligence and the perception that an e-learning management system is easy to use (PEU).	Not Supported
13 There is a negative relationship between naturalist (NL) intelligence and the perceived usefulness (PU) of an e-learning management system.	Not Supported
14 There is a negative relationship between naturalist (NL) intelligence and the perception that an e-learning management system is easy to use (PEU).	Not Supported

Table 4.1: Hypotheses Outcomes

Hypothesis	Result
15 There is a positive relationship between verbal/linguistic (VL) intelligence and the perceived usefulness (PU) of an e-learning management system.	Not Supported
16 There is a positive relationship between verbal/linguistic (VL) intelligence and the perception that an e-learning management system is easy to use (PEU).	Not Supported
17 There is a positive relationship between the perceived ease of use (PEU) of an e-learning management system and its usefulness (PU).	Supported
18 There is a positive relationship between the perceived usefulness (PU) of an e-learning management system and the attitude (ATU) to use such a system.	Supported
19 There is a positive relationship between the perceived ease of use (PEU) of an e-learning management system and the attitude (ATU) to use such a system.	Not Supported
20 There is a positive relationship between the attitude (ATU) to use an e-learning management system and the behavioral intention (BI) to use such a system.	Supported

Figure 4.1: MI Extended TAM Model

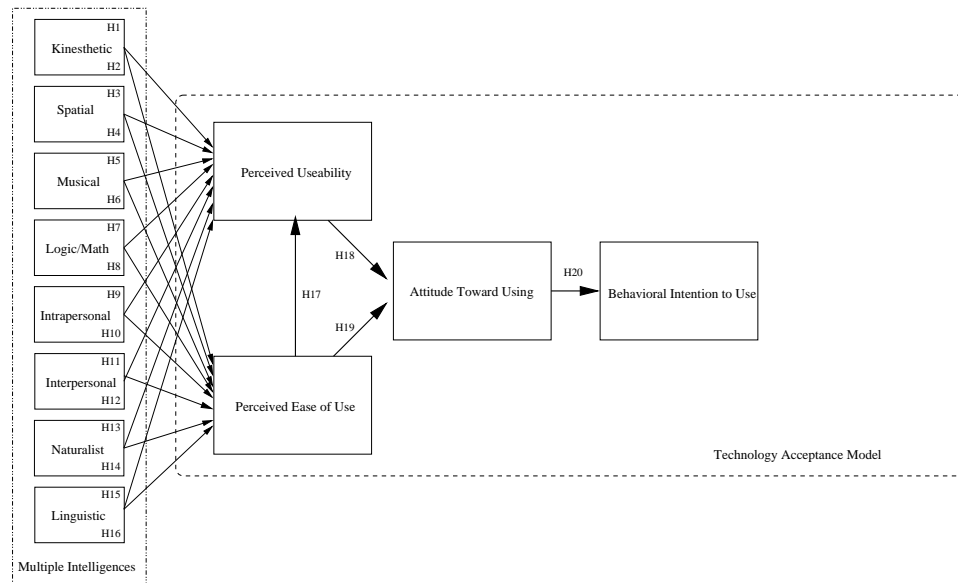

To begin, students were queried as to their level of usage of various computer and Internet technologies, Figure 4.2 displays their responses and Table 4.2 gives the summary statistics for the questions asked. 75% of students surveyed reported using a computer on a daily basis, Figure 4.2(a). 81% of students find navigating the Internet easy to do, Figure 4.2(b). 71% consider themselves expert at using the Internet, Figure 4.2(c), and Figure 4.2(d) reveals that 67% consider themselves expert in the use of a computer. Figure 4.2(f) shows that 99% of students surveyed report having an email account, with most having 2-3 active accounts. Figure 4.2(i) indicates that 94% of students use social networking applications such as Facebook, MySpace, Twitter, et cetera. Where Figure 4.2(j) shows that 90% use the Internet for activities that include email, online games, news, chats, wikis, downloading music or videos, blogs, et cetera.

In contrast, only 39% of the students surveyed reported using a computer to do homework regularly, Figure 4.2(e). 74% report having never taken an online class, Figure 4.2(g).

While Figure 4.2(h) shows that 62% have had 4 or fewer classes that make assignments that use the Internet. So, while the students in this study were well connected and adequately versed in computer and Internet technology, they did not generally use the technology to accomplish academic goals.

Prior to discussing the results of the Multiple Intelligence enhanced TAM model, it is necessary to first confirm that the TAM and the MIDAS behave as Davis, et. al. and Shearer anticipate. In the following discussion the TAM model is examined and results confirmed. The MIDAS results are reported and checked for reliability. After each instrument is evaluated on its own merits, the proposed MI-TAM model is considered.

Figure 4.2: Student Uses of Computer Technology [144]

Figures (a) through (d) use a 7-point scale varying from 'Strongly Disagree' to 'Strongly Agree'. Figure (e) uses a 5-point scale varying from 'Never' to 'Daily'. Figures (f) through (h) use a 5-point scale with the assignment: 1='0', 2='1-2', 3='3-4', 4='5-6', and 5='7 or More'. Figure (i) counts the number of different types of typical social networking accounts a student may hold and ranges from 0 through 10. Figure (j) counts the number of different types of common information sources a student may visit and ranges from 0 to 11. See Appendix I for a copy of the survey used.

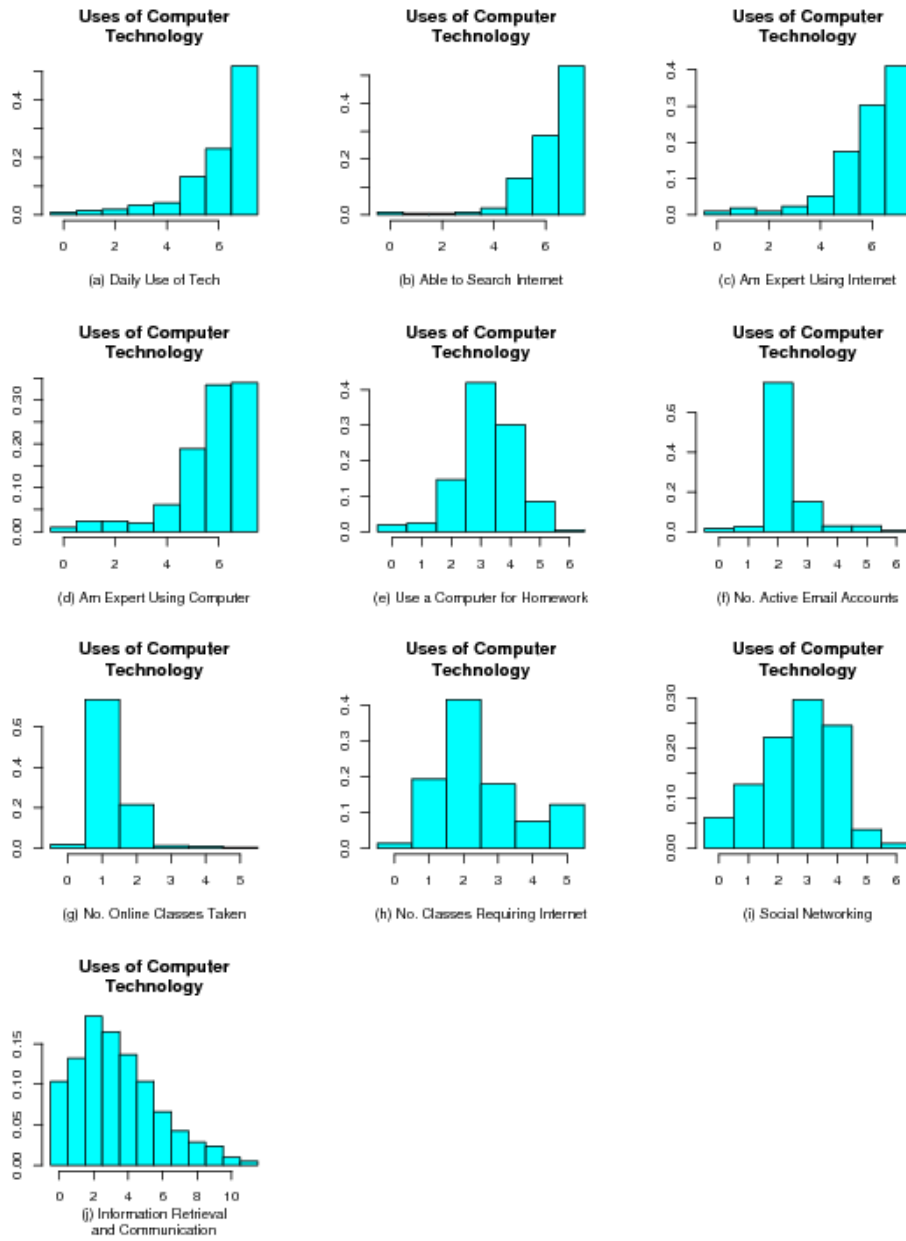

Table 4.2: Uses of Computer Technology: Descriptive Statistics [35, 142]

Entries (a) through (d) use a 7-point scale varying from 'Strongly Disagree' to 'Strongly Agree'. Entry (e) uses a 5-point scale varying from 'Never' to 'Daily'. Entries (f) through (h) use a 5-point scale with the assignment: 1='0', 2='1-2', 3='3-4', 4='5-6', and 5='7 or More'. Entry (i) counts the number of different types of typical social networking accounts a student may hold and ranges from 0 through 10. Entry (j) counts the number of different types of common information sources a student may visit and ranges from 0 to 11. See Appendix I for a copy of the survey used.

	(a)Daily Use of Technology	(b)Able to Search Internet	(c)Able to Expert Using Internet	(d)Able to Expert Using Computer	(e)Use a Computer for Homework
1	Min.: 0.00	Min.: 0.00	Min.: 0.00	Min.: 0.00	Min.: 0.00
2	1st Quartile: 5.75	1st Quartile: 6.00	1st Quartile: 5.00	1st Quartile: 5.00	1st Quartile: 3.00
3	Median: 7.00	Median: 7.00	Median: 6.00	Median: 6.00	Median: 3.00
4	Mean: 6.00	Mean: 6.23	Mean: 5.87	Mean: 5.70	Mean: 3.24
5	3rd Quartile: 7.00	3rd Quartile: 7.00	3rd Quartile: 7.00	3rd Quartile: 7.00	3rd Quartile: 4.00
6	Max.: 7.00	Max.: 7.00	Max.: 7.00	Max.: 7.00	Max.: 6.00
	(f)Number of Active Email Accounts	(g)Number of Online Classes Taken	(h)Number of Classes Requiring Internet	(i)Social Networking Accounts	(j)Information Retrieval and Communication
1	Min.: 0.00	Min.: 0.00	Min.: 0.00	Min.: 0.00	Min.: 0.00
2	1st Quartile: 2.00	1st Quartile: 1.00	1st Quartile: 2.00	1st Quartile: 2.00	1st Quartile: 2.00
3	Median: 2.00	Median: 1.00	Median: 2.00	Median: 3.00	Median: 3.00
4	Mean: 2.26	Mean: 1.27	Mean: 2.48	Mean: 2.69	Mean: 3.34
5	3rd Quartile: 2.00	3rd Quartile: 1.00	3rd Quartile: 3.00	3rd Quartile: 4.00	3rd Quartile: 5.00
6	Max.: 6.00	Max.: 5.00	Max.: 5.00	Max.: 6.00	Max.: 11.00

4.1 Analysis of Findings
 4.1.1 Technology Acceptance Model

The TAM survey asked 40 questions and was divided into four sections as follows: eleven questions concerning Perceived Ease of Use, four questions concerning Behavioral Intention to Use, nineteen questions concerning Perceived Usefulness, and six questions concerning Attitude Toward Using. The frequency of responses are detailed in Tables 4.3, 4.4, 4.5, 4.6, and 4.7. Of the 212 cases very few had missing data. Given that not much information will be lost, only complete cases will be used for further analysis. That is, missing values will be ignored for purposes of calculations only.

Table 4.8 reports the coefficient alpha, a measure of internal consistency, for each of the individual TAM sections. The values range from 0.90 to 0.98 suggesting a high degree of internal reliability for the TAM survey. High reliability helps to avoid under-estimating relationships between variates and reduces the risk of Type II errors [128].

Table 4.8: Technology Acceptance Model Survey: Internal Reliability [144]

TAM Items Surveyed	Cronbach's Alpha
Perceived Ease of Use	0.95
Perceived Usefulness	0.98
Attitude Toward Using	0.96
Behavioral Intention to Use	0.90

To facilitate further analysis¹, the mean value of each of the TAM sections will be

¹Each section contained differing number of questions, using the average puts everything on a scale of 1 to 7 and allows factors to be compared meaningfully.

Table 4.3: Technology Acceptance Model Factor: Perceived Usefulness (Part 1)[190]

pu01								pu06									
	n	missing		unique			Mean		n	missing		unique			Mean		
	212		0		7		5.491		212		0		7		4.892		
		1	2	3	4	5	6	7			1	2	3	4	5	6	7
Frequency	3	2	4	32	50	80	41	Frequency	5	5	3	79	44	55	21		
%	1	1	2	15	24	38	19	%	2	2	1	37	21	26	10		
pu02								pu07									
	n	missing		unique			Mean		n	missing		unique			Mean		
	212		0		7		5.057		210		2		7		4.824		
		1	2	3	4	5	6	7			1	2	3	4	5	6	7
Frequency	5	6	10	43	59	65	24	Frequency	6	6	4	81	37	58	18		
%	2	3	5	20	28	31	11	%	3	3	2	39	18	28	9		
pu03								pu08									
	n	missing		unique			Mean		n	missing		unique			Mean		
	211		1		7		4.976		212		0		7		4.868		
		1	2	3	4	5	6	7			1	2	3	4	5	6	7
Frequency	5	4	8	63	48	60	23	Frequency	6	4	10	69	48	53	22		
%	2	2	4	30	23	28	11	%	3	2	5	33	23	25	10		
pu04								pu09									
	n	missing		unique			Mean		n	missing		unique			Mean		
	209		3		7		4.794		208		4		7		4.913		
		1	2	3	4	5	6	7			1	2	3	4	5	6	7
Frequency	5	4	10	77	43	54	16	Frequency	5	3	6	71	51	50	22		
%	2	2	5	37	21	26	8	%	2	1	3	34	25	24	11		
pu05								pu10									
	n	missing		unique			Mean		n	missing		unique			Mean		
	207		5		7		5.261		211		1		7		4.943		
		1	2	3	4	5	6	7			1	2	3	4	5	6	7
Frequency	5	3	6	42	46	73	32	Frequency	6	3	3	75	47	52	25		
%	2	1	3	20	22	35	15	%	3	1	1	36	22	25	12		

used as the metric for each TAM factor and will be referred to by name as PEUmean, PUmean, ATUmean, and BIUmean, for the mean of students' responses for Perceived Ease of Use, Perceived Usefulness, Attitude Toward Using, and Behavioral Intention to Use, respectively. Summary statistics for each of the factors are given in Table 4.9. From the table it may be seen that each factor has a mean and median value greater than the midpoint of the survey range value: (4) *Neither Agree nor Disagree*. This fact suggests that on

Table 4.4: Technology Acceptance Model Factor: Perceived Usefulness (Part 2)[190]

pu11									
	n	missing	unique				Mean		
	212	0	7				5.396		
			1	2	3	4	5	6	7
Frequency	6	1	1	42	41	87	34		
%	3	0	0	20	19	41	16		

pu12									
	n	missing	unique				Mean		
	212	0	7				5.024		
			1	2	3	4	5	6	7
Frequency	4	5	13	59	42	57	32		
%	2	2	6	28	20	27	15		

pu13									
	n	missing	unique				Mean		
	211	1	7				5.076		
			1	2	3	4	5	6	7
Frequency	5	4	7	62	38	66	29		
%	2	2	3	29	18	31	14		

pu14									
	n	missing	unique				Mean		
	212	0	7				5.259		
			1	2	3	4	5	6	7
Frequency	3	3	4	57	36	77	32		
%	1	1	2	27	17	36	15		

pu15									
	n	missing	unique				Mean		
	212	0	7				5.354		
			1	2	3	4	5	6	7
Frequency	6	3	2	47	36	77	41		
%	3	1	1	22	17	36	19		

pu16									
	n	missing	unique				Mean		
	210	2	7				5.629		
			1	2	3	4	5	6	7
Frequency	6	2	3	24	43	72	60		
%	3	1	1	11	20	34	29		

pu17									
	n	missing	unique				Mean		
	210	2	7				5.39		
			1	2	3	4	5	6	7
Frequency	8	2	4	36	41	74	45		
%	4	1	2	17	20	35	21		

pu18									
	n	missing	unique				Mean		
	211	1	7				5.327		
			1	2	3	4	5	6	7
Frequency	7	4	7	35	43	72	43		
%	3	2	3	17	20	34	20		

pu19									
	n	missing	unique				Mean		
	212	0	7				5.042		
			1	2	3	4	5	6	7
Frequency	7	5	9	57	44	53	37		
%	3	2	4	27	21	25	17		

average students agree with the statements that elearning using Moodle is easy and useful, moreover they indicate that students would be inclined to use the elearning platform were it made available.

Figure 4.3 displays a histogram for each of the TAM factors and a normal plot with the corresponding mean and standard deviation superimposed. A qualitative examination of the plots suggest that the TAM factors for this study are not normally distributed. A chi-square test for goodness-of-fit is given in the upper left-hand corner of each plot. In addition, the Shapiro-Wilk W test for normality was performed with results stated in Table 4.10. From both tests the null hypothesis that the data are normally distributed is to be rejected for each TAM factor. This result is of some concern as it may bias or otherwise impair the results of the regressions that are forthcoming.

Figure 4.4 shows a pairwise analysis of each of the TAM factors. The figure is laid out in a 4x4 grid with the lower left-hand section depicting scatter plots of the factor pairs, the diagonal the labels of each of the factors represented, and the upper right-hand section the correlations between the factors. To identify which pairs of factors are represented in any portion of the figure one need only look to the column and row of the diagonal. For example, to determine which factor pairs are plotted in the lower left portion of the figure look to the diagonal. This block of the figure is in the PEUmean column (above) and the BIUmean row (right). For purposes of reading the scatter plots, the column represents what is on the x-axis, while the row will represent what is on the y-axis. Therefore, the lower left block in the figure is a scatter plot of PEUmean on the x-axis (scaled 1-7) and BIUmean on the y-axis (scaled 1-7).

The scatter plots in Figure 4.4 include a LOESS line fitted to the data. LOESS is a polynomial curve fitting method (locally weighted least squares[104, 182]) for fitting smooth curves to data sets. The LOESS line provides a good first pass assessment of the kind of relationship that may exist between factors. Here each plot shows an essentially lin-

Figure 4.3: TAM FactorMean Histograms [33]

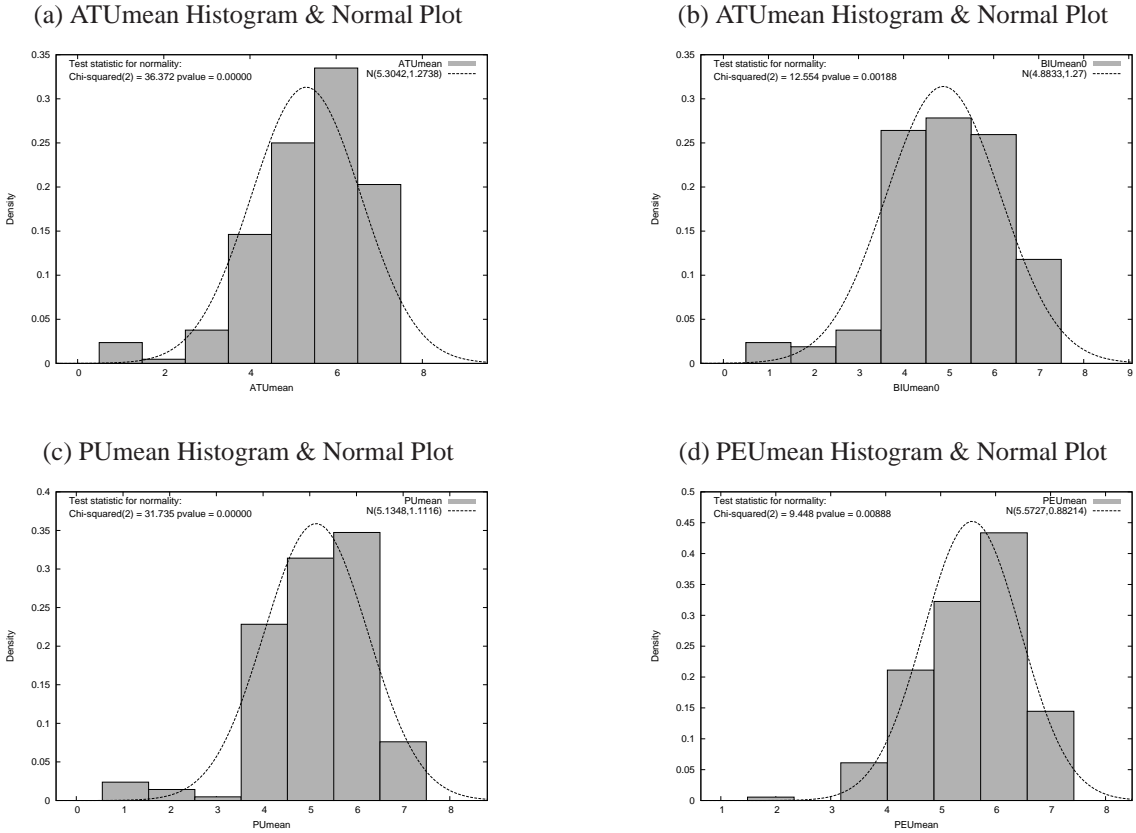

ear relationship. If the line were curved it would suggest a nonlinear relationship between the variates. In such a case an application of Mosteller and Tukey’s Bulging Rule (1977) [63, 104, 197] would provide a useful strategy for linearizing the data.

The values in the upper right show the pairwise correlations (Pearson’s correlation, r) between TAM factors. The correlations are positive and range from 0.64 to 0.88, representing large effect sizes (exceeding ± 0.50 [51]). The strength of the apparent relationships and their direction support those identified in the Technology Acceptance Model. In the next sections those connections will be examined more fully.

Figure 4.4: Technology Acceptance Model: Data Plots and Correlations Between Factor Means [144]

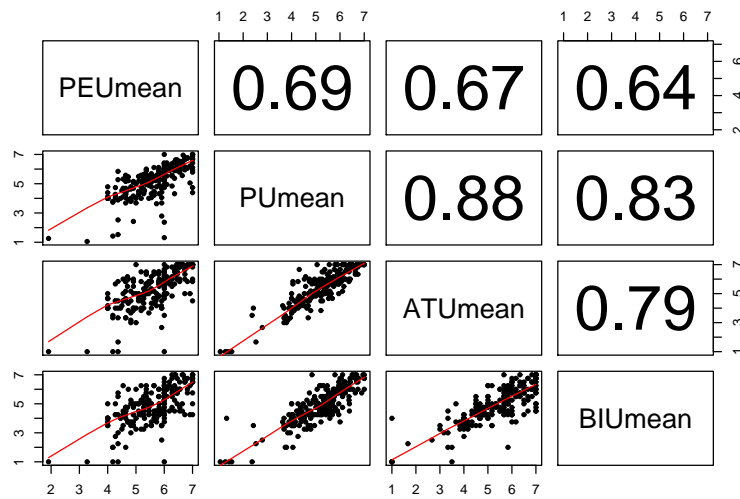

Table 4.5: Technology Acceptance Model Factor: Perceived Ease of Use [190]

peu01						peu06												
	n	missing	unique	Mean		n	missing	unique	Mean		n	missing	unique	Mean				
	211	1	6	5.645		211	1	5	5.545		211	1	5	5.545				
		1	3	4	5	6	7					3	4	5	6	7		
Frequency	1	2	29	44	97	38					2	36	61	69	43			
%	0	1	14	21	46	18					1	17	29	33	20			
peu02						peu07												
	n	missing	unique	Mean		n	missing	unique	Mean		n	missing	unique	Mean				
	211	1	6	5.588		211	1	7	5.502		211	1	7	5.502				
		1	3	4	5	6	7					1	2	3	4	5	6	7
Frequency	1	1	32	48	96	33					1	1	2	44	39	87	37	
%	0	0	15	23	45	16					0	0	1	21	18	41	18	
peu03						peu08												
	n	missing	unique	Mean		n	missing	unique	Mean		n	missing	unique	Mean				
	211	1	6	5.825		211	1	6	5.545		211	1	6	5.545				
		1	3	4	5	6	7					1	3	4	5	6	7	
Frequency	1	1	22	35	102	50					1	3	40	42	85	40		
%	0	0	10	17	48	24					0	1	19	20	40	19		
peu04						peu09												
	n	missing	unique	Mean		n	missing	unique	Mean		n	missing	unique	Mean				
	207	5	6	5.483		211	1	7	5.607		211	1	7	5.607				
		1	3	4	5	6	7					1	2	3	4	5	6	7
Frequency	1	1	42	53	72	38					1	1	1	37	42	84	45	
%	0	0	20	26	35	18					0	0	0	18	20	40	21	
peu05						peu10												
	n	missing	unique	Mean		n	missing	unique	Mean		n	missing	unique	Mean				
	208	4	6	5.505		210	2	6	5.595		210	2	6	5.595				
		1	3	4	5	6	7					1	3	4	5	6	7	
Frequency	1	3	52	36	65	51					1	4	36	42	81	46		
%	0	1	25	17	31	25					0	2	17	20	39	22		
peu11						peu11												
	n	missing	unique	Mean		n	missing	unique	Mean		n	missing	unique	Mean				
	211	1	6	5.455		211	1	6	5.455		211	1	6	5.455				
		1	3	4	5	6	7					1	3	4	5	6	7	
Frequency	2	2	44	51	72	40					2	2	44	51	72	40		
%	1	1	21	24	34	19					1	1	21	24	34	19		

Table 4.6: Technology Acceptance Model Factor: Behavioral Intention to Use [190]

biu01									
	n	missing	unique					Mean	
	211	1						4.796	
			1	2	3	4	5	6	7
Frequency	11	10	14	41	54	62	19		
%			5	5	7	19	26	29	9

biu02									
	n	missing	unique					Mean	
	212	0						4.962	
			1	2	3	4	5	6	7
Frequency	7	4	17	60	43	36	45		
%			3	2	8	28	20	17	21

biu03									
	n	missing	unique					Mean	
	212	0						4.844	
			1	2	3	4	5	6	7
Frequency	5	7	7	77	41	51	24		
%			2	3	3	36	19	24	11

biu04									
	n	missing	unique					Mean	
	212	0						4.92	
			1	2	3	4	5	6	7
Frequency	5	7	8	67	47	49	29		
%			2	3	4	32	22	23	14

Table 4.7: Technology Acceptance Model Factor: Attitude Toward Using [190]

atu01									
	n	missing	unique					Mean	
	212	0						5.028	
			1	2	3	4	5	6	7
Frequency	7	5	9	48	55	61	27		
%			3	2	4	23	26	29	13

atu02									
	n	missing	unique					Mean	
	212	0						5.245	
			1	2	3	4	5	6	7
Frequency	7	7	7	38	42	69	42		
%			3	3	3	18	20	33	20

atu03									
	n	missing	unique					Mean	
	212	0						5.264	
			1	2	3	4	5	6	7
Frequency	6	2	8	40	55	60	41		
%			3	1	4	19	26	28	19

atu04									
	n	missing	unique					Mean	
	211	1						5.46	
			1	2	3	4	5	6	7
Frequency	5	2	3	37	46	70	48		
%			2	1	1	18	22	33	23

atu05									
	n	missing	unique					Mean	
	211	1						5.436	
			1	2	3	4	5	6	7
Frequency	6	2	5	35	47	65	51		
%			3	1	2	17	22	31	24

atu06									
	n	missing	unique					Mean	
	211	1						5.398	
			1	2	3	4	5	6	7
Frequency	6	1	4	44	40	69	47		
%			3	0	2	21	19	33	22

Table 4.9: TAM *FactorMean* Summary Statistics [33]

**Summary Statistics, using the observations 1–212
for the variable *PEUmean* (212 valid observations)**

Mean	Median	Minimum	Maximum
5.57267	5.72727	1.90909	7.00000
Std. Dev.	C.V.	Skewness	Ex. kurtosis
0.882138	0.158297	−0.506775	0.294064

**Summary Statistics, using the observations 1–212
for the variable *ATUmean* (212 valid observations)**

Mean	Median	Minimum	Maximum
5.30425	5.66667	1.00000	7.00000
Std. Dev.	C.V.	Skewness	Ex. kurtosis
1.27378	0.240143	−1.00050	1.44842

**Summary Statistics, using the observations 1–212
for the variable *PUmean* (212 valid observations)**

Mean	Median	Minimum	Maximum
5.13484	5.27047	1.05263	7.00000
Std. Dev.	C.V.	Skewness	Ex. kurtosis
1.11157	0.216475	−0.999637	1.74908

**Summary Statistics, using the observations 1–212
for the variable *BIUmean* (212 valid observations)**

Mean	Median	Minimum	Maximum
4.88325	5.00000	1.00000	7.00000
Std. Dev.	C.V.	Skewness	Ex. kurtosis
1.26996	0.260063	−0.606585	0.618922

Where C.V., the coefficient of variation, is given by $c_v = \frac{s}{\bar{x}}$. Ex. kurtosis, excess kurtosis, is given by $\frac{1}{n-1} \sum (x_i - \bar{x})^4 / s^4 - 3$, where n is sample size, s is variance, x_i a sample data point, and \bar{x} the sample mean. Excess relates to the normal distribution which has a kurtosis of 3, positive values imply a kurtosis greater than that of the normal distribution, a negative value less than that of the normal distribution. [3, 80]

Table 4.10: Tests for Normality of the TAM *FactorMeans* [33]

Shapiro-Wilk W		
TAM Factor	Test Statistic	P-value
PEUmean	0.9651	4.2982e-005
PUmean	0.9368	5.9536e-008
BIUmean	0.9581	6.9662e-006
ATUmean	0.9232	4.5690e-009

4.1.1.1 Relationship between Perceived Usefulness and Perceived Ease of Use (PU ~ PEU)

Table 4.11: Pearson Correlation: PEUmean & PUmean

Pearson's product-moment correlation
data: PEUmean and PUmean
t = 13.9082, df = 210, p-value < 2.2e-16
alternative hypothesis: true correlation is not equal to 0
95 percent confidence interval:
0.6150810 - 0.7565941
sample estimates:
cor
0.6924396

The Technology Acceptance Model posits that Perceived Usefulness of a technology is determined by the Perceived Ease of Use of that technology [38, 47, 105]. From this statement the following hypothesis is put forth:

Hypothesis 17: There is a positive relationship between the perceived ease of use (PEU) of an e-learning management system (MOODLE) and its usefulness (PU).

In this case it is the (e)learning management system Moodle that is the technology under investigation. The hypothesis is tested using a simple linear regression² to determine how the two variables PEU and PU, as represented by PEUmean and PUmean respectively, may be related and the strength of that relationship [85]. Table 4.13(a) gives the results of the regression calculations and Figure 4.5(a) shows the plot of the regression line. The PEUmean

²See also W. M. Trochim's Selecting Statistics at <http://www.socialresearchmethods.net/selstat/ssstart.htm>

coefficient is estimated to be $\beta_1 = 0.87$ (at a confidence interval of .749 to 0.996 with an alpha of 0.05) and is highly significant with $p = 1.33e - 31$. The adjusted coefficient of determination of the model is $R^2 = 0.48$. The table also gives the results of the F-test for the null hypothesis: H_0 : the coefficients of the regression are all equal to zero. The values of $F(1,210)=193.44$ and $P\text{-value}(F) = 1.33e-31$ suggest that H_0 is to be rejected. The regression model is significant but can be improved upon.

The scatter plot, Figure 4.5(a), has a number of points positioned far from the main cluster which may qualify as outliers. For this model, the leverage equation 3.3 (see Section 3.3.4.3) yields the following cutoff value:

$$2\bar{h} = \frac{2(1+1)}{212} = 0.01887$$

Therefore, values of $h_i > 0.01887$ should be dropped from the regression model. Twelve influential points are identified using this technique and are tagged with an asterisk (*) in Table 4.12. Twelve points for 17 classes is less than one student per class (5.6% of the data) being discarded and is considered acceptable.

Table 4.13(b) shows the results of the regression after the influential points have been dropped. The slope of the regression line has changed to $\beta_1 = 0.8607$ yet remains highly significant, $p=4.33e-24$. In addition, the adjusted coefficient of determination has decreased slightly to $R^2 = 0.4018$. The new regression line has been plotted in Figure 4.5(b) and appears to be more representative of the data set. Criteria for selecting between the competing models (AIC, BIC, and HQC see Section 3.3.4.5) are included in Table 4.13. The regression model with influential values removed has lower measures for each of these criteria, hence, is an improvement on the original regression. Therefore this model will be used as the basis for further analysis. It is important to emphasize that AIC, BIC, and HQC are relative measures and are only relevant for the comparison of competing models, not for confirming a model's validity.

Figure 4.5: Regression Lines Plotted [33]

(a) Regression line with influential values present

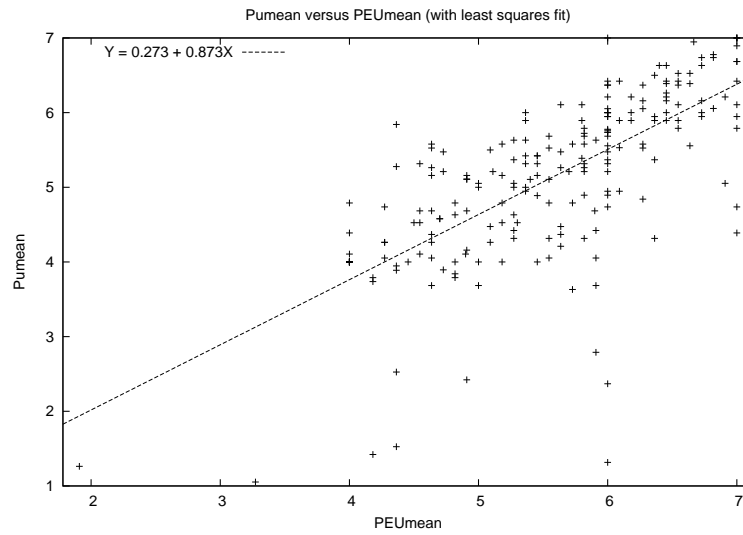

(b) Regression line with influential values removed

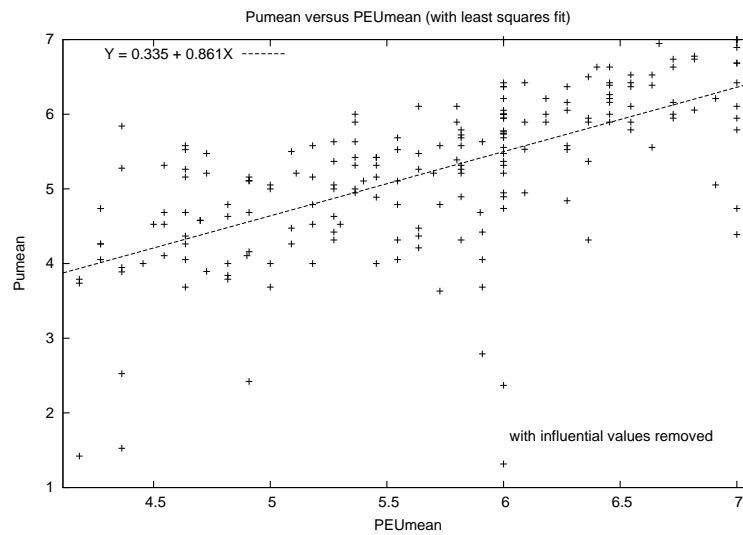

Table 4.12: PU~PEU: Leverage

	residual	leverage	influence
u		$0 \leq h \leq 1$	$u \cdot h / (1-h)$
11	0.24	0.020*	0.00479
21	0.24	0.020*	0.00479
33	0.24	0.020*	0.00479
58	0.24	0.020*	0.00479
59	0.24	0.020*	0.00479
123	-2.08	0.037*	-0.07959
129	0.24	0.020*	0.00479
140	0.24	0.020*	0.00479
158	-0.68	0.086*	-0.06389
162	0.34	0.020*	0.00691
166	1.03	0.020*	0.02072
189	0.63	0.020*	0.01264

TESTING REGRESSION ASSUMPTIONS: Residual plots are depicted in Figure 4.6. Figure 4.6(a) plots the residuals versus the dependent variable PEUmean, the pattern is customary to ordinary least squares regression³ and does not signal a source of deviation from the regression assumptions. The second plot, Figure 4.6(b), shows the residuals versus the independent variable PEUmean. The second plot shows no obvious patterns and has points scattered equally above and below the zero line. The second plot is suggestive of the presence of outliers.

The assumption of functional form seems to be supported by both the scatter plots and the residuals above. The results of Ramsey's RESET (see Section 3.3.4.2) are given in Table 4.14. In each case the null hypothesis (γ_i equal to 0) cannot be rejected.

³For explanation see <http://csob.berry.edu/faculty/economics/gretlguide/olsguide/Textfile.html#ToInfluentialObservationsTest>

Table 4.13: Regression Model: PU ~ PEU [33]

Model $PU \sim PEU$ (a) OLS estimates using the 212 observations 1–212
 Dependent variable: PUmean

	Coefficient	Std. Error	p-value
const	0.2725	0.3539	0.4422
PEUmean	0.8725	0.0627	0.0000
Mean dependent var	5.134842	S.D. dependent var	1.111566
Sum squared resid	135.7053	S.E. of regression	0.803876
R^2	0.479473	Adjusted R^2	0.476994
$F(1, 210)$	193.4369	P-value(F)	1.33e–31
Log-likelihood	–253.5283	Akaike criterion	511.0567
Schwarz criterion	517.7698	Hannan–Quinn	513.7700

Model $PU \sim PEU$ (b) OLS estimates using the 200 observations 1–200
 Dependent variable: PUmean

	Coefficient	Std. Error	p-value
const	0.3350	0.4252	0.4317
PEUmean	0.8607	0.0742	0.0000
Mean dependent var	5.224936	S.D. dependent var	1.043474
Sum squared resid	128.9632	S.E. of regression	0.807050
R^2	0.404819	Adjusted R^2	0.401813
$F(1, 198)$	134.6717	P-value(F)	4.33e–24
Log-likelihood	–239.9087	Akaike criterion	483.8174
Schwarz criterion	490.4140	Hannan–Quinn	486.4869

Figure 4.6: PU~PEU: Residuals of Predicted Values

(a) Residuals versus Predicted Variable (PUmean)

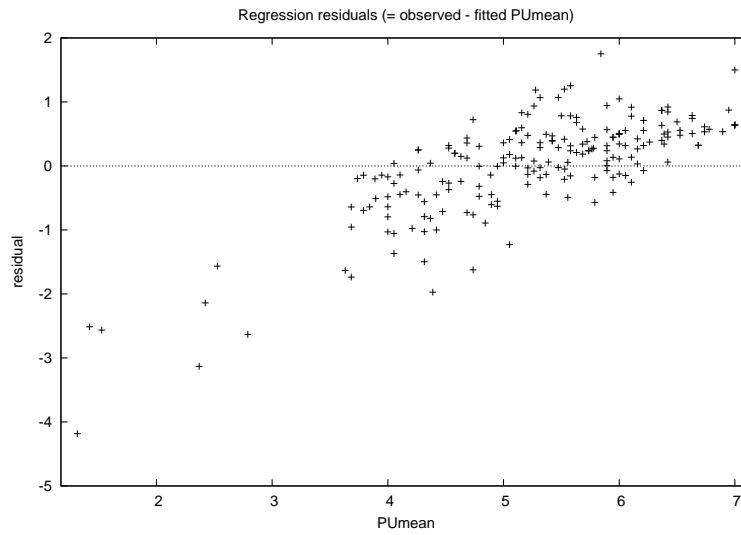

(b) Residuals versus Independent Variable (PEUmean)

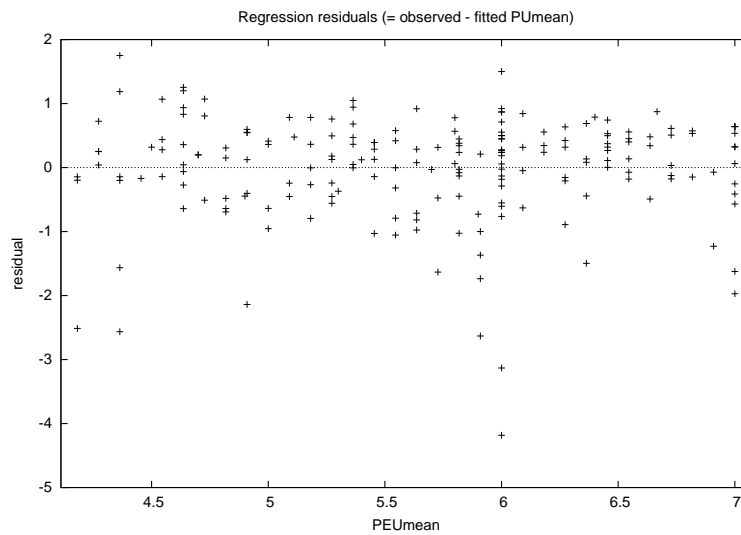

Table 4.14: PU~PEU: Test for Nonlinearity

RESET test for specification (squares and cubes)

Test statistic: $F = 0.102243$,

with p-value = $P(F(2,196) > 0.102243) = 0.903$

RESET test for specification (cubes only)

Test statistic: $F = 0.014466$,

with p-value = $P(F(1,197) > 0.0144656) = 0.904$

RESET test for specification (squares only)

Test statistic: $F = 0.019028$,

with p-value = $P(F(1,197) > 0.019028) = 0.89$

Hence, it is concluded that the linear form of the model is an appropriate one to use.

As stated in Section 3.3.1, the study was conducted so as to include all members of the selected small school. There were no activities or holidays during the length of the study that would have served to detract from the collection of data or bias the results. Moreover, the TAM portion of the study was presented and collected in one 50 minute period without the need for extension. Students were directed to complete the TAM survey quietly and independently, which they did. Those students who did not complete and/or submit the survey are assumed to be randomly distributed throughout the sample. From this evidence it is supposed that the observations collected were random and independent. Likewise the residuals of the regression are expected to be independent as there is no notion of adjacency (either in time or place) or source of interdependence of data points that would otherwise bias the results.

The results of White's Test for homogeneity of variance are given in Table 4.15. In this case the null hypothesis H_0 : *is heteroskedasticity is not present*, cannot be rejected (p-value = 0.7519) and it is concluded that the residuals are homoskedastic with a constant variance across all levels of the independent variable [63, 113].

Table 4.15: PU~PEU: Heteroskedasticity

White's test for heteroskedasticity -

Null hypothesis: heteroskedasticity not present

Test statistic: LM = 0.57023

with p-value = $P(\text{Chi-Square}(2) > 0.57023) = 0.751928$

Table 4.16: PU~PEU: Normality of Residuals

Test for normality of residual -

Null hypothesis: error is normally distributed

Test statistic: Chi-square(2) = 81.4101

with p-value = 2.099e-018

The test for normality is done using a Chi-square goodness-of-fit test on the residuals, results given in Table 4.16. Figure 4.7 depicts a histogram of the residuals with a normal plot superimposed. The plot is taller (kurtosis = 2.087697) than the normal curve and skewed to the left (skewness = -1.697327). The value for kurtosis is a little greater than one would like (preferred range ± 2 for approximately normal distributions) but with an acceptable skewness. These facts together with the largish sample size allows one to conclude that the distribution is nearly normal and allows analysis continue.

Even after the initial deletion of data values with undue leverage there is still the presence of influential points. Figure 4.8 gives a plot of the standardized residuals versus leverage. Standardized residuals given by

$$s_i = \frac{e_i}{\sqrt{\frac{\sum (Y_i - \hat{Y}_i)^2}{n - p}}}$$

have a variance of 1. Standardized residuals greater than ± 2 are considered large. A number of points meet this criterion (three are highlighted in the plot). In addition the plot shows that in this revised data set (n=200) there remain six points beyond the 0.01887

Figure 4.7: PU~PEU: Residuals Test for Normality

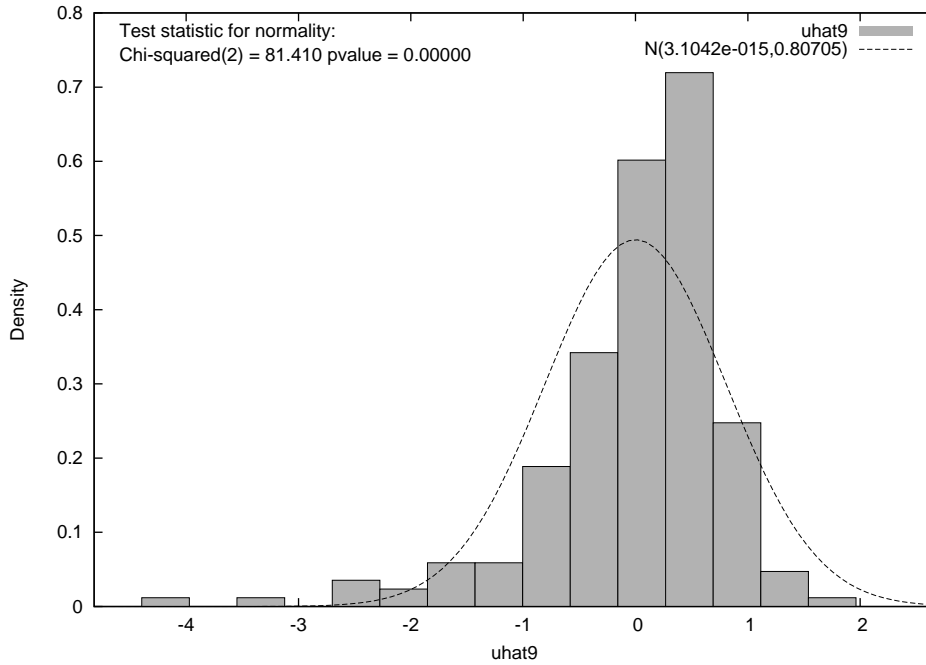

cutoff for leverage established above (see 3.3). Given that the draconian measures taken on influential points identified earlier did not substantially alter the regression results no further pruning will be done. Instead R^2 will be adjusted as follows.

According to Osborne, et. al. the true relationship between variables may be obscured by noise introduced by measurement errors, et cetera. Adjustments may be made for a simple regression by the formulation [128]:

$$r_{12}^* = \frac{r_{12}}{\sqrt{r_{11}r_{22}}} \quad (4.1)$$

where r_{12}^* is the true reliability between variables 1 and 2, r_{12} is the observed correlation, and r_{11} and r_{22} are the estimated reliabilities of the individual variables. For the PU ~ PEU model equation 4.1 gives the following⁴:

$$r_{PU \sim PEU}^* = \frac{r_{PU \sim PEU}}{\sqrt{r_{PU}r_{PEU}}} = \frac{\sqrt{0.40488}}{\sqrt{(0.98)(0.95)}} = 0.6594$$

⁴correlation coefficient for 200 cases is recalculated to be $r=0.6363$.

Figure 4.8: PU~PEU: Influence

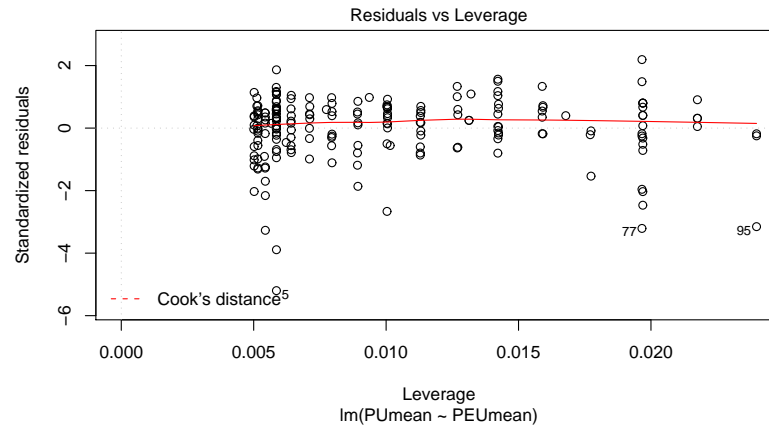

and

$$(r_{PU \sim PEU}^*)^2 = (0.6594)^2 = 0.4348$$

adjusted becomes:

$$(r_{PU \sim PEU}^*)_{adjusted}^2 = 1 - (1 - 0.4348) \frac{200 - 1}{200 - 2 - 1} = 0.4291$$

The new value is not that much greater than what was reported earlier, due to the high internal reliability of the TAM survey.

It is concluded that hypothesis 17 is supported, i.e. there is a positive relationship between perceived ease of use of the learning management system Moodle and a perceived usefulness of that learning management system. Hence this portion of the TAM is confirmed.

4.1.1.2 Relationship between Attitude Toward Using and Perceived Usefulness and Perceived Ease of Use (ATU ~ PU + PEU)

Table 4.17: Pearson Correlation: ATU & PU, ATU & PEU

Pearson's product-moment correlation
data: PUmean and ATUmean
t = 27.4577, df = 210, p-value < 2.2e-16
alternative hypothesis: true correlation is not equal to 0
95 percent confidence interval:
0.8510590 0.9106175
sample estimates:
cor
0.884387

According to the Technology Acceptance Model the two antecedents of a positive attitude toward a new technology or software are the user's perceptions of its perceived ease of use and its perceived usefulness [38, 47, 105]. From this statement two hypotheses are drawn:

Hypothesis 18: There is a positive relationship between the perceived usefulness (PU) of an e-learning management system (MOODLE) and the attitude (ATU) to use such a system.

Hypothesis 19: There is a positive relationship between the perceived ease of use (PEU) of an e-learning management system (MOODLE) and the attitude (ATU) to use such a system.

The LOESS curves drawn in Figure 4.4 show the relationship between perceived ease of use (PEUmean) and attitude toward using (ATUmean), as well as the relationship between

perceived usefulness (PUmean) and attitude toward using (ATUmean) to be essentially linear. The correlations reported in Figure 4.4 and restated with confidence intervals in Table 4.17 show a strong positive correlation between each of the variates. As no curvilinear relationship is suggested by either of these analyses, a multiple linear regression will be used to assess this portion of the TAM hypotheses.

The results of the multiple regression are given in Table 4.18. Each predictor variable is significant at the $\alpha = 0.05$ level, as is the model itself. Checking for influential values is done using the diagonal of the hat matrix and the formulation given in Equation 3.3. The threshold value is calculated as follows:

$$h_i > 2\bar{h} = \frac{2(2+1)}{212} = 0.0283$$

Twelve values are identified as having exceeded $2\bar{h}$ with this method and are listed in Table 4.19. These values have been pruned from the data set and the regression model recalculated with $n=200$. The results of the new regression model are given in 4.18(b). The new model gives a greater value for the coefficient of PEUmean and a lesser coefficient for PUmean, both coefficients remain significant. While the R^2 value has decreased the preferred measures of the competing models, given by the information criterion measures AIC, BIC, and HQC, each indicate that the new model is a better choice (i.e. all values less than corresponding previous measures, see Table 3.9.)

Testing the null hypothesis that the betas are all zero ($H_0 : \beta_0 = \beta_1 = \beta_2 = 0$) produces an $F(2,197)=224.8782$ and a $p\text{-value}(F)=1.03e-51$. Hence the null hypothesis is rejected, signaling that the model has utility for predicting values of ATUmean (explaining almost 70% of the variance in ATUmean). Turning to the betas it is clear that PUmean is greater than PEUmean. Supposing for the moment that a direct comparison is unfounded in that there is no reason to assume they are measured in comparable units. One may remove the

Table 4.18: ATU~PEU+PU

Model $ATU \sim PEU + PU$ (a): OLS, using observations 1–212
 Dependent variable: ATUmean

	Coefficient	Std. Error	<i>t</i> -ratio	p-value
const	−0.303831	0.260109	−1.1681	0.2441
PEUmean	0.146930	0.0638131	2.3025	0.0223
PUmean	0.932703	0.0506421	18.4176	0.0000
Mean dependent var	5.304245	S.D. dependent var	1.273776	
Sum squared resid	72.73877	S.E. of regression	0.589943	
R^2	0.787530	Adjusted R^2	0.785497	
$F(2, 209)$	387.3341	P-value(F)	5.04e−71	
Log-likelihood	−187.4255	Akaike criterion	380.8510	
Schwarz criterion	390.9208	Hannan–Quinn	384.9210	

Model $ATU \sim PEU + PU$ (b): OLS, using observations 1–200
 Dependent variable: ATUmean

	Coefficient	Std. Error	<i>t</i> -ratio	p-value
const	−0.0987476	0.288598	−0.3422	0.7326
PEUmean	0.187252	0.0780013	2.4006	0.0173
PUmean	0.852587	0.0725802	11.7468	0.0000
Mean dependent var	5.457500	S.D. dependent var	1.048249	
Sum squared resid	66.39981	S.E. of regression	0.580564	
R^2	0.696342	Adjusted R^2	0.693259	
$F(2, 197)$	225.8782	P-value(F)	1.03e−51	
Log-likelihood	−173.5254	Akaike criterion	353.0508	
Schwarz criterion	362.9457	Hannan–Quinn	357.0551	

Figure 4.9: ATU~PEU+PU:Plot Actual versus Fitted ATUmean

(a) Regression line with influential values present

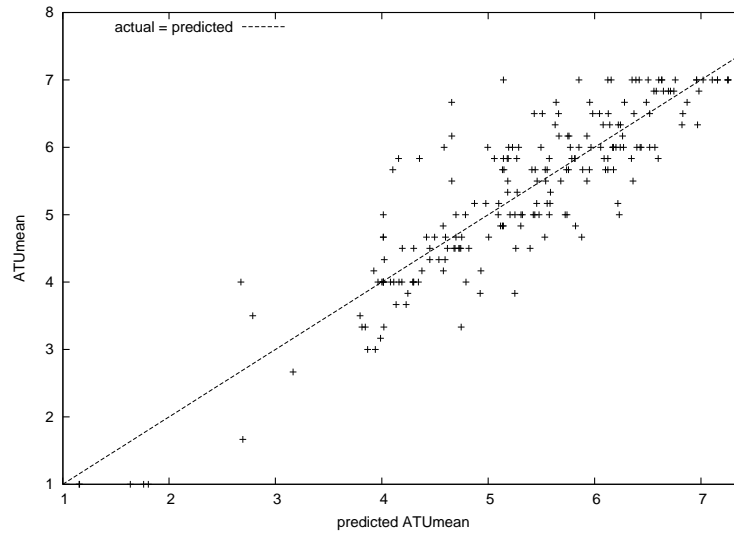

(b) Regression line with influential values removed

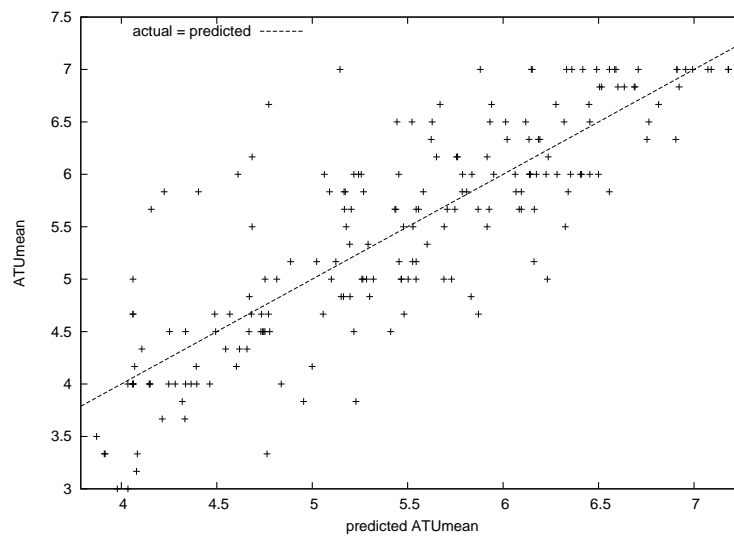

Table 4.19: ATU~PU+PEU: Influential Values

	residual u	leverage 0<=h<=1	influence u*h/(1-h)
5	-0.8	0.135*	-0.13
35	0.05	0.037*	0
36	0.71	0.078*	0.06
62	-0.32	0.046*	-0.02
82	-0.76	0.062*	-0.05
100	-0.64	0.063*	-0.04
113	-0.5	0.057*	-0.03
123	-0.16	0.069*	-0.01
141	0.69	0.037*	0.03
154	1.32	0.041*	0.06
158	-0.15	0.090*	-0.02
203	-1.03	0.031*	-0.03

influence of unit by standardizing the betas as follows:

$$B_i = \beta_i \left(\frac{s_{x_i}}{s_y} \right)$$

where B_i is the standardized beta, s_{x_i} the sample standard deviation of i^{th} independent variable, and s_y the standard deviation of the dependent variable y [104, 113]. This formulation gives:

$$B_{PEUmean} = \beta_{PEUmean} \left(\frac{s_{PEUmean}}{s_{ATUmean}} \right) = 0.187252 \left(\frac{0.8202226}{1.048249} \right) = 0.1465189$$

and

$$B_{PUmean} = \beta_{PUmean} \left(\frac{s_{PUmean}}{s_{ATUmean}} \right) = 0.852587 \left(\frac{0.8814856}{1.048249} \right) = 0.716951$$

Hence for each increase of one standard deviation of PEUmean one may expect ATUmean to increase by about 0.15 standard deviations, and for each increase of one standard deviation of PUmean a corresponding increase of 0.72 standard deviations in ATUmean may

be expected. Hence, PUmean has a much greater impact (4.8 times greater) on ATUmean than does PEUmean⁵. Hair et. al. give a rule of thumb suggesting that predictor variables that are more closely related to the best predictor than to the dependent variable should be excluded from the regression model [63, page 37]. Looking back to Figure 4.4, PEUmean has a higher correlation to PUmean (0.69) than to ATUmean (0.67), and PUmean is the best predictor of ATUmean with a correlation 0.88. Were it not for testing the TAM model, one would conclude that PEUmean should not be included in the regression based on this rule of thumb and its contribution. The next step is to confirm the regression assumptions for this model.

TESTING REGRESSION ASSUMPTIONS: The residuals for this model are plotted in figure 4.10. Figure 4.10(a) shows a slight increase from left to right which is an artifact of the ordinary least squares regression method and of little concern. Figure 4.10(b) shows a random distribution of points about the horizontal line at 0. The third plot, Figure 4.10(c), however, shows a narrowing from left to right a pattern which may be of some concern and warrants further investigation. A t-test of the residuals, Table 4.20 shows the mean of the residuals to be zero.

Ramsey's RESET is used to confirm that a linear functional form of this regression is appropriate. The test adds nonlinear terms of the fitted values to the regression equation and everything is re-run. If the model is not mis-specified then the additional terms should not improve the regression. Table 4.21 reports the results of including squared terms, cubic terms, and the combination of both cubic and squared terms to the regression equation. The null hypothesis that the coefficients of the new terms are zero cannot be rejected in any of the cases presented. Hence the linear form is an adequate functional form for this

⁵The technique does carry some controversy see <http://www.jerrydallal.com/LHSP/importnt.htm>

Figure 4.10: $ATU \sim PEU + PU$: Residuals

(a) Residuals versus Predicted Variable (ATUmean)

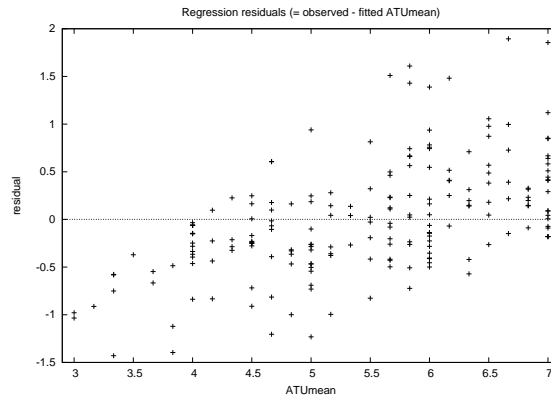

(b) Residuals versus Independent Variable (PEUmean)

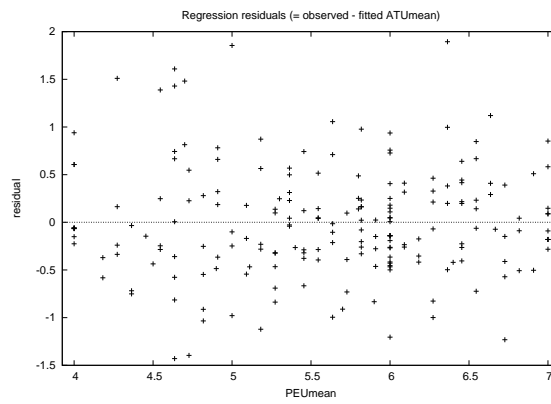

(c) Residuals versus Independent Variable (PUmean)

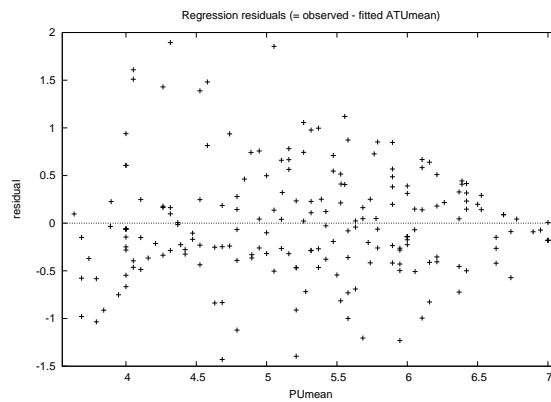

Table 4.20: ATU~PEU+PU

One Sample t-test

data: ATU~PEU+PU: residuals
t = 0, df = 199, p-value = 1
alternative hypothesis: true mean is not equal to 0
95 percent confidence interval:
-0.08054512 0.08054512
sample estimates:
mean of x
5.713474e-18

Table 4.21: ATU~PEU+PU: linearity

RESET test for specification (squares and cubes)
Test statistic: $F = 0.938153$,
with p-value = $P(F(2,195) > 0.938153) = 0.393$

RESET test for specification (cubes only)
Test statistic: $F = 1.323952$,
with p-value = $P(F(1,196) > 1.32395) = 0.251$

RESET test for specification (squares only)
Test statistic: $F = 1.232830$,
with p-value = $P(F(1,196) > 1.23283) = 0.268$

regression.

The patterns in the partial residual plots were troubling and suggest a non-homoskedastic distribution of the residuals. White's test rejects the null hypothesis that residuals are homoskedastic, Table 4.22. This finding presents a difficulty, in that the data observed with high variance will provide less information about the true location of the regression line than the information derived from observations with lesser variance [3]. It becomes necessary to correct for the error using the methodology set forth in Section 3.3.4.4 and run a

Table 4.22: ATU~PEU+PU: Heteroskedasticity

White's test for heteroskedasticity -

Null hypothesis: heteroskedasticity not present

Test statistic: LM = 12.1503

with p-value = $P(\text{Chi-Square}(5) > 12.1503) = 0.0327849$

Table 4.23: ATU~PEU+PU: Corrected Model

Model $ATU \sim PEU + PU$: Heteroskedasticity-corrected, using observations 1–200

Dependent variable: ATUmean

	Coefficient	Std. Error	<i>t</i> -ratio	p-value
const	−0.0608560	0.253579	−0.2400	0.8106
PEUmean	0.136530	0.0755879	1.8062	0.0724
PUmean	0.890485	0.0606511	14.6821	0.0000

Statistics based on the weighted data:

Sum squared resid	706.6969	S.E. of regression	1.894015
R^2	0.804059	Adjusted R^2	0.802070
$F(2, 197)$	404.2034	P-value(F)	1.88e−70

weighted least squares regression.

The results of the heteroskedasticity corrected weighted least squares regression are given in Table 4.23. The coefficient of determination has increased to $R^2 = 0.80$. PUmean remains highly significant, but PEUmean is no longer significant at the $\alpha = 0.05$ level (PEUmean is significant at $\alpha = 0.10$). The disparity in contribution between PEUmean and PUmean has widened, with PUmean having on the order of a seven times greater effect than PEUmean on the outcome of ATUmean. The analysis that follows will be based on this corrected model.

Figure 4.4 and Table 4.17 give the correlations between ATUmean, PEUmean, and

Table 4.24: ATU~PEU+PU: Multicollinearity [33]

Variance Inflation Factors

Minimum possible value = 1.0

Values > 10.0 may indicate a collinearity problem

PEUmean	2.417
PUmean	2.417

$VIF(j) = 1/(1 - R(j)^2)$, where $R(j)$ is the multiple correlation coefficient between variable j and the other independent variables

PUmean. Each factor is correlated to every other factor in the group. It is necessary then to assess whether there is any multicollinearity that may be unduly influencing this regression. Recall one of the regression assumptions is that the predictor variables are independent of one another. This may be a moot point, given that it has already been demonstrated that PUmean depends in part upon PEUmean. What needs to be done is to determine whether this obvious connection will detract from the current regression model. To make this determination the Variance Influence Factors (VIF) for each of the independent variables is calculated (see Table 4.24 for the formulation). Large VIF values denote high collinearity, i.e. the variability of one variable is well explained by the presence of another independent variable. As a rule of thumb, VIF values greater than 10 are considered high. Table 4.24 gives the results of this test. Neither of the VIF values exceed the cutoff, so both PEUmean and PUmean will be allowed to remain in the regression model.

Figure 4.11 plots the histogram of the residuals with the normal curve superimposed. The $\chi^2(2) = 9.818$ with an associated p-value=0.00738 rejects the formal assumption that the residuals are normally distributed. However, the histogram does not vary dramatically from the normal, being a little taller in the middle and a little heavy on the right tail.

Figure 4.11: ATU~PEU+PU: Normality of Residuals

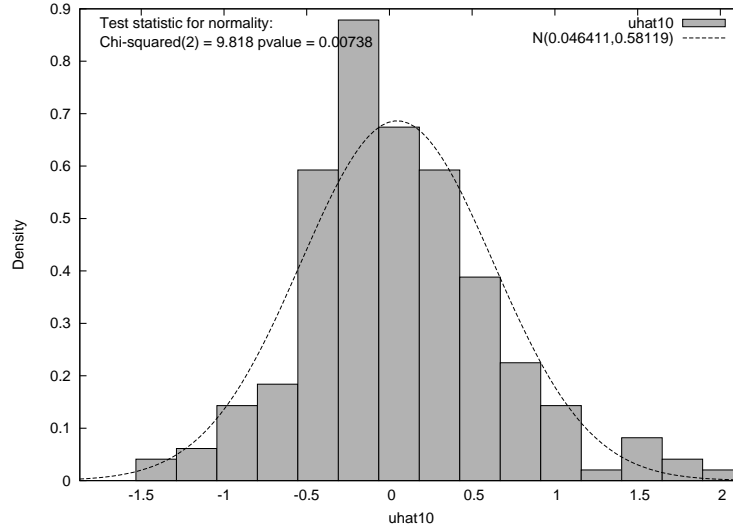

Calculated values for skewness=0.53 and excess kurtosis=0.9 are both with ± 1 , which is considered a stringent criterion for normality⁶. This information coupled with sample size suggest that the normality assumption is reasonable, and that the regression analysis may proceed.

As before, pruning the data set of influential values did not remove all trouble points. Figure 4.12 plots the Standardized Residuals against Leverage (see Equation 3.3). Approximately 10 points fall outside of two standard deviations from the horizontal line at 0, and an additional eight points exceed the $2\bar{h} = 0.0283$ threshold established earlier. The LOESS line also plotted in the figure suggests that the regression line may be pulled by these latter points off of the zero horizontal line. No further attempt is made to remove these values from the regression model at this point.

The confidence intervals for the independent variables are given in Table 4.25. Based on these results it is determined that hypothesis 18 is fully supported with a highly significant coefficient of nearly 1.0 for the perceived usefulness factor and an explained variance

⁶see <http://faculty.chass.ncsu.edu/garson/PA765/assumpt.htm>

Figure 4.12: ATU~PEU+PU: Influence

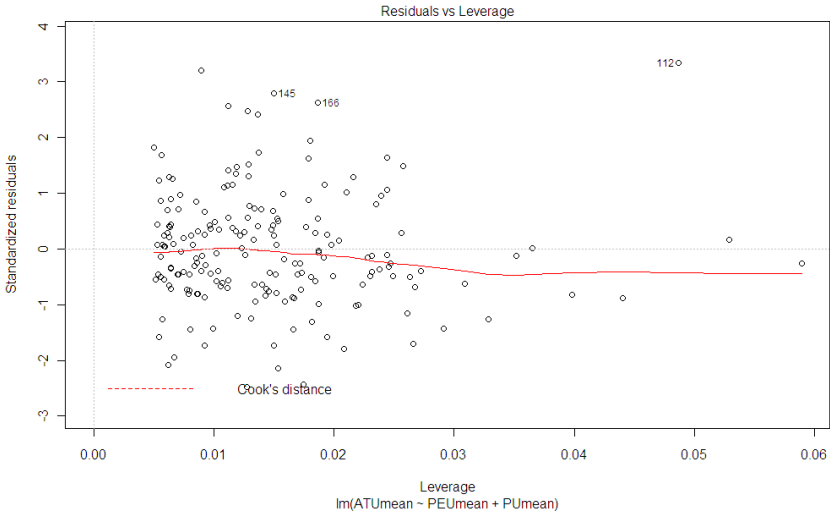

for the regression model of 80%. PEUmean, however, is not supported in this model, as the confidence interval for PEUmean ranges from -0.013 to 0.29 and includes 0. Dropping PEUmean from the model results in a drop in the adjusted R^2 to 0.76 but would be considered an improvement as the information criteria measures AIC, BIC, and HQC all show a decrease in value (calculations omitted). The result is that hypothesis 19 is not supported, or more formally, that the null hypothesis which places the beta for PEUmean at zero cannot be rejected. Consequently, the TAM theory is only partially supported by this study.

Table 4.25: ATU~PEU+PU: Confidence Intervals

$t(197, 0.025) = 1.972$

Variable	Coefficient	95% confidence interval	
const	-0.0608560	-0.560934	0.439222
PEUmean	0.136530	-0.0125354	0.285595
PUmean	0.890485	0.770876	1.01009

4.1.1.3 Relationship between Behavioral Intention to Use and Attitude Toward Using (BIU ~ ATU)

Table 4.26: Pearson Correlation: ATU & BIU

Pearson's product-moment correlation

data: BIUmean and ATUmean

$t = 18.798$, $df = 210$, $p\text{-value} < 2.2e-16$

alternative hypothesis: true correlation is not equal to 0

95 percent confidence interval:

0.7357555 - 0.8373707

sample estimates:

cor

0.7919852

The TAM asserts that a positive attitude toward a technology (Attitude to Use) will lead to the behavior of using and/or adopting that technology (Behavioral Intention to Use) [38, 47, 105]. It is from this assertion that the next hypothesis is drawn:

Hypothesis 20: There is a positive relationship between the attitude (ATU) to use an e-learning management system (MOODLE) and the behavioral intention (BI) to use

such a system.

Once again the relationship is tested using a simple linear regression, as suggested by both the TAM theory and the LOESS plot in Figure 4.4. Results of the regression are given in Table 4.27(a). The model has an adjusted coefficient of determination $R^2 = 0.625466$ with a highly significant beta of $\beta_1 = 0.789610$ and a p-value of $p = 6.92e - 47$. The F-test suggests that one is to reject the null hypothesis that the coefficient and constant of the regression are both 0 with an $F(1,210) = 353.3661$ yielding a p-value for the F-test of $p = 6.92e - 47$.

The calculation for the cutoff value for excessive leverage (twice the average leverage value [113]) was performed in Equation 3.3 and continues to apply here ($n=212$, $k=1$). There are nine values that exceed the $2\bar{h} = 0.01887$, these points are listed in Table 4.28. As before, points with excessive leverage are dropped and the model re-evaluated. The results of the new model are given in Table 4.27(b). Comparing the new and old models show that the information criteria measures AIC, BIC, and HQC all have lower values indicating an improvement, not withstanding the drop in R^2 . Figure 4.13 shows the regression line applied to both sets of data. Once again, a visual inspection confirms a better fit. The revised model will provide the basis for the remaining analysis.

The revised model betas are significant at the $\alpha = 0.05$ level and have 95% confidence intervals given in Table 4.29 (where $t_{(N-p, \alpha/2)} = t(201, 0.025) = 1.972$ is the student t-distribution). Neither interval contains 0 which is suggestive. Testing the utility of the model by checking the null hypothesis that $\beta_0 = \beta_1 = 0$ gives an $F(1,201) = 236.12$ with $P\text{-value}(F) = 9.38e - 36$. The result is that the null hypothesis is to be rejected, and that the betas are nonzero. Hence the model is significant with an adjusted $R^2 = 0.54$, but still needs to be checked against the regression assumptions.

Table 4.27: BIU~ATU

Model $BIU \sim ATU$ (a) OLS estimates using the 212 observations 1–212
 Dependent variable: BIUmean

	Coefficient	Std. Error	<i>t</i> -ratio	p-value
const	0.694969	0.229109	3.0334	0.0027
ATUmean	0.789610	0.0420049	18.7980	0.0000
Mean dependent var	4.883255	S.D. dependent var	1.269956	
Sum squared resid	126.8493	S.E. of regression	0.777203	
R^2	0.627241	Adjusted R^2	0.625466	
$F(1, 210)$	353.3661	P-value(F)	6.92e-47	
Log-likelihood	-246.3748	Akaike criterion	496.7496	
Schwarz criterion	503.4628	Hannan–Quinn	499.4629	

Model $BIU \sim ATU$ (b) OLS estimates using the 203 observations 1–203
 Dependent variable: BIUmean

	Coefficient	Std. Error	<i>t</i> -ratio	p-value
const	0.582600	0.292744	1.9901	0.0479
ATUmean	0.809150	0.0526575	15.3663	0.0000
Mean dependent var	5.003695	S.D. dependent var	1.132464	
Sum squared resid	119.1223	S.E. of regression	0.769836	
R^2	0.540174	Adjusted R^2	0.537887	
$F(1, 201)$	236.1223	P-value(F)	9.38e-36	
Log-likelihood	-233.9394	Akaike criterion	471.8788	
Schwarz criterion	478.5052	Hannan–Quinn	474.5596	

Figure 4.13: BIU~ATU: Regression Line Plots

(a) Regression line with influential values present.

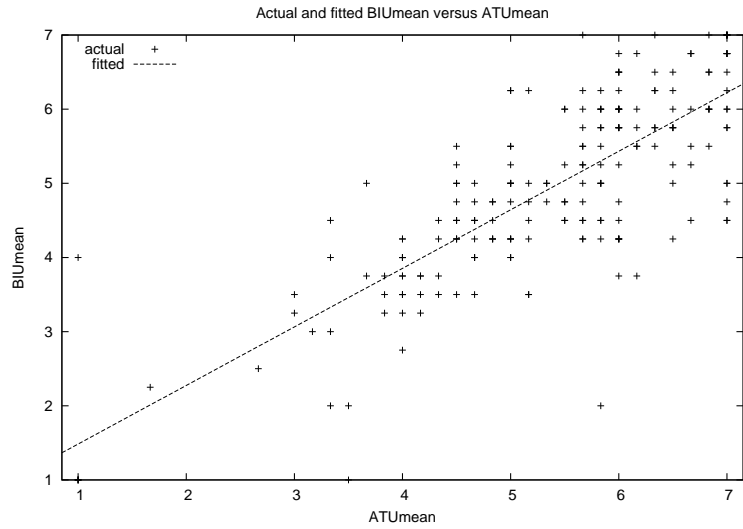

(b) Regression line with influential values removed.

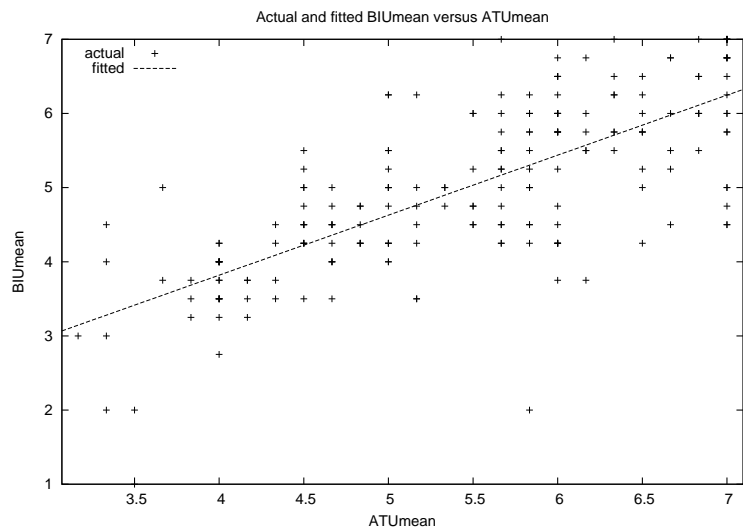

Table 4.28: Leverage for BIU~ATU [33]

observation	residual u	leverage $0 \leq h \leq 1$	influence $u \cdot h / (1-h)$
5	2.52	0.059*	0.16
48	0.19	0.020*	0
82	-0.48	0.059*	-0.03
92	0.44	0.020*	0.01
100	-0.48	0.059*	-0.03
113	-0.3	0.025*	-0.01
123	-0.48	0.059*	-0.03
158	-0.48	0.059*	-0.03
203	0.24	0.043*	0.01

Table 4.29: BIU~ATU: Confidence Intervals

$$t(201, 0.025) = 1.972$$

Variable	Coefficient	95% confidence interval	
const	0.582600	0.00535668	1.15984
ATUmean	0.809150	0.705318	0.912982

TESTING REGRESSION ASSUMPTIONS: The residuals for this model are plotted in Figure 4.14. Figure 4.14(a) shows the usual pattern for ordinary least squares residuals, and Figure 4.14(b) shows a random scattering of residuals above and below the horizontal line at 0. A t-test confirms that the mean of the residuals is 0 (results given in Table 4.30). Each of these tests are strong indications of goodness-of-fit of a linear model. However, some points seem to be located very far from the 0 line suggesting a need to test for additional influential values.

To confirm that the functional form of the model should be linear Ramsey's RESET

Figure 4.14: BIU~ATU: Residuals

(a) Residuals versus Predicted Variable (BIUmean)

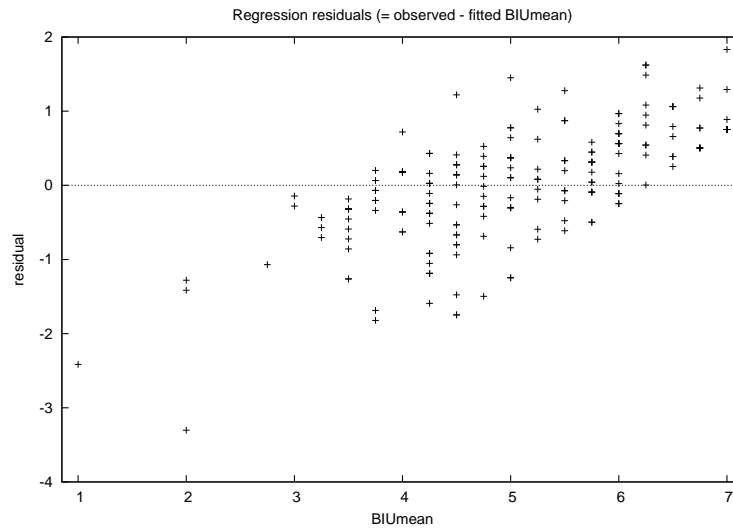

(b) Residuals versus Independent Variable (ATUmean)

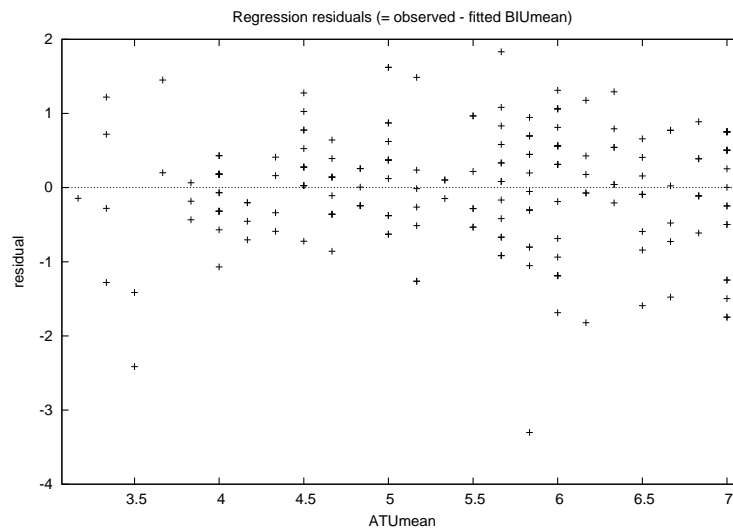

Table 4.30: BIU~ATU: t-test zero mean for residuals

One Sample t-test

data: BIU~ATU Model residuals

t = 0, df = 202, p-value = 1

alternative hypothesis: true mean is not equal to 0

95 percent confidence interval:

-0.1062749 - 0.1062749

sample estimates:

mean of x

-6.534588e-18

Table 4.31: Ramsey's RESET for BIU~ATU [33]

RESET test for specification (squares and cubes)

Test statistic: $F = 1.131829$,

with p-value = $P(F(2,199) > 1.13183) = 0.325$

RESET test for specification (cubes only)

Test statistic: $F = 1.960293$,

with p-value = $P(F(1,200) > 1.96029) = 0.163$

RESET test for specification (squares only)

Test statistic: $F = 1.863334$,

with p-value = $P(F(1,200) > 1.86333) = 0.174$

test is performed. The results of the test are given in Table 4.31. The tests deny the need for the addition of nonlinear combinations of the independent variable ATUmean into the model. More precisely, the null hypothesis that betas of the nonlinear terms are 0 cannot be rejected. Therefore the model is assumed to not be mis-specified and linearity is confirmed.

White's Test is performed to check for heteroskedasticity, results in Table 4.32. The null hypothesis that the residuals are homoskedastic cannot be rejected (p-value=0.457293). It is determined that the residuals exhibit a constant variance across all values of x. More

Table 4.32: BIU~ATU: Homoskedasticity of Residuals

White's test for heteroskedasticity -

Null hypothesis: heteroskedasticity not present

Test statistic: LM = 1.56486

with p-value = $P(\text{Chi-Square}(2) > 1.56486) = 0.457293$

importantly, it is concluded that tests of significance of the predictor variables are not invalidated and inferences drawn from the regression model about the significance of ATUmean are appropriate.

The histogram of residuals with a normal plot, $N(\text{mean}=7.3723\text{e-}016, 0.76984)$, superimposed is given in Figure 4.15. The formal Chi-square test rejects normality with a $\chi^2(2) = 14.355$ and a p-value=0.00078. The residuals appear to be very nearly normally distributed but for the presence of a few data points with largish negative errors and a higher than normal peak. Checking, the residuals are found to have a *skewness* = -0.403 and an *excesskurtosis* = 1.6. These values are within the usual range⁷ of ± 2 . This fact coupled with the large sample size and the robust nature of regression are sufficient to claim the residuals are nearly normally distributed and that analysis may proceed.

Twice above results have been made suspect by the presence of possible influential points continuing to lurk in the data. Figure 4.16 confirms the existence of multiple problem points, with eight points exceeding the threshold leverage value of 0.018 and another twelve data points exceeding 2 standard deviations from zero line with cases 148, 19, and 35 being most detrimental. The first data pruning reduced the coefficient of determination by 0.09 while doing very little to alter the ATUmean coefficient or its importance, or the importance of the model as a whole. Recalling that the purpose of this regression is to confirm the TAM constructs it is not necessary to prune the data set further to establish the desired result.

⁷See <http://faculty.chass.ncsu.edu/harson/PA765/assumpt.htm>

Figure 4.15: BIU~ATU: Test for Normality of Residuals

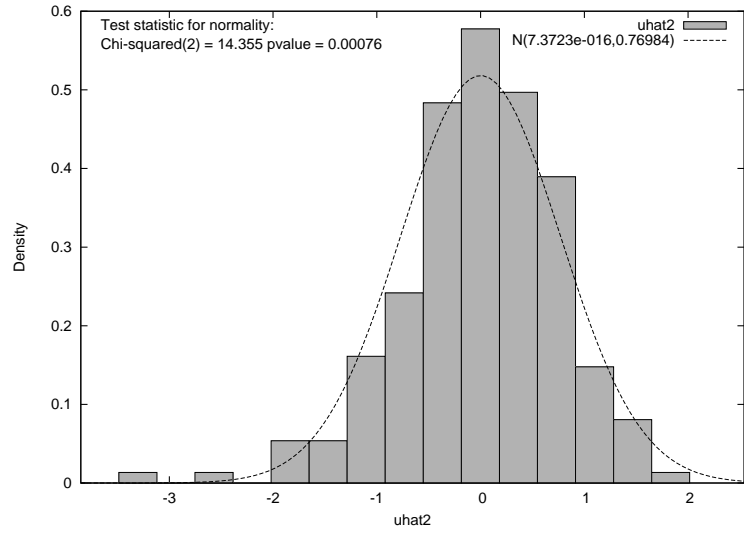
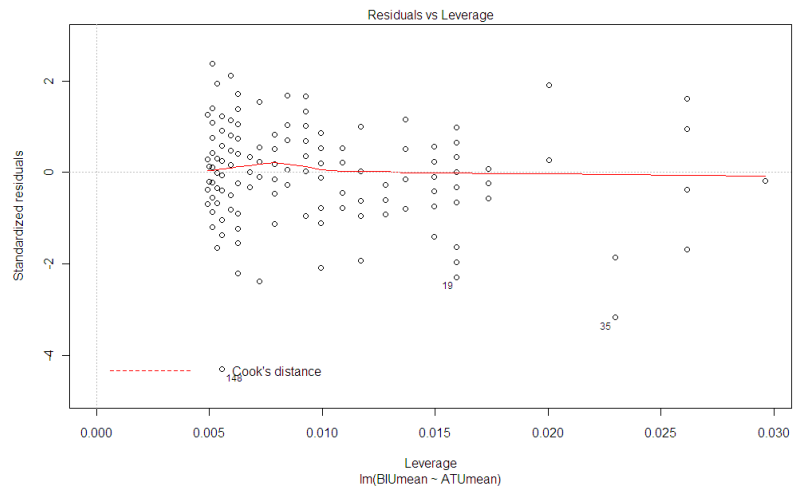

Figure 4.16: BIU~ATU: Influence Points



While the betas for the regression need not be adjusted further, it may be of some use to address the attenuation of the data by applying Osborne's calculation (Equation 4.1) for a better approximation of r^2 (R^2 for simple regression) as follows [128]:

$$r_{BIU \sim ATU}^* = \frac{r_{BIU \sim ATU}}{\sqrt{r_{BIU} r_{ATU}}} = \frac{\sqrt{0.540174}}{\sqrt{(0.9581)(0.9232)}} = 0.7815$$

$$(r_{BIU \sim ATU}^*)^2 = 0.6107$$

adjusted becomes:

$$(r_{BIU \sim ATU}^*)_{adjusted}^2 = 1 - (1 - 0.6107) \left(\frac{203 - 1}{203 - 2 - 1} \right) = 0.6068$$

From this analysis it is evident that Hypothesis 20 is confirmed and that the TAM model is supported.

4.1.2 Multiple Intelligences Developmental Assessment Scales (MIDAS)

The MIDAS multiple intelligence scores range from 0 to 100 with 50 being the median value, a score considered to demonstrate adequate development in the given area[163]. Scores are ranked from Very High to Very Low according to the scale given in Table 4.33. Students who take the MIDAS receive a personalized profile that is comprised of three parts: 1) a page raw scores and category ranks clustered by multiple intelligence, 2) a histogram of their scores on each of the eight intelligences, and 3) a list of specific skills listed from highest to lowest MIDAS score. A sample profile may be found in Appendix H.

Reliability scores were calculated for each of the multiple intelligences tested. The coefficient alphas, see Table 4.34, range in value from 0.75 to 0.90 and are in alignment with results reported by Shearer [161]. The scores suggest a high internal reliability for the MIDAS assessment. Moreover the high scores provide confidence that this portion of the study was conducted within the recommended guidelines [161]. Previously there was

Table 4.33: MIDAS Score Categories [163]

Range	Category
100-80	Very High
80-60	High
60-40	Moderate
40-20	Low
20-0	Very Low

a concern as it was individual classroom teachers who administered the MIDAS, not the researcher.

Table 4.34: MIDAS Reliabilities

Scale	α
Musical	0.86
Kinesthetic	0.77
Math/Logic	0.87
Spatial	0.87
Linguistic	0.90
Interpersonal	0.87
Intrapersonal	0.75
Naturalist	0.90

Figure 4.17 gives a box-and-whiskers plot of the MIDAS scores for each intelligence. The plots are summarized in Table 4.35. The median scores and their 90% confidence intervals for all but Naturalist intelligence fall within the middlemost MODERATE ranking.

Figure 4.17: MIDAS Intelligences Boxplots

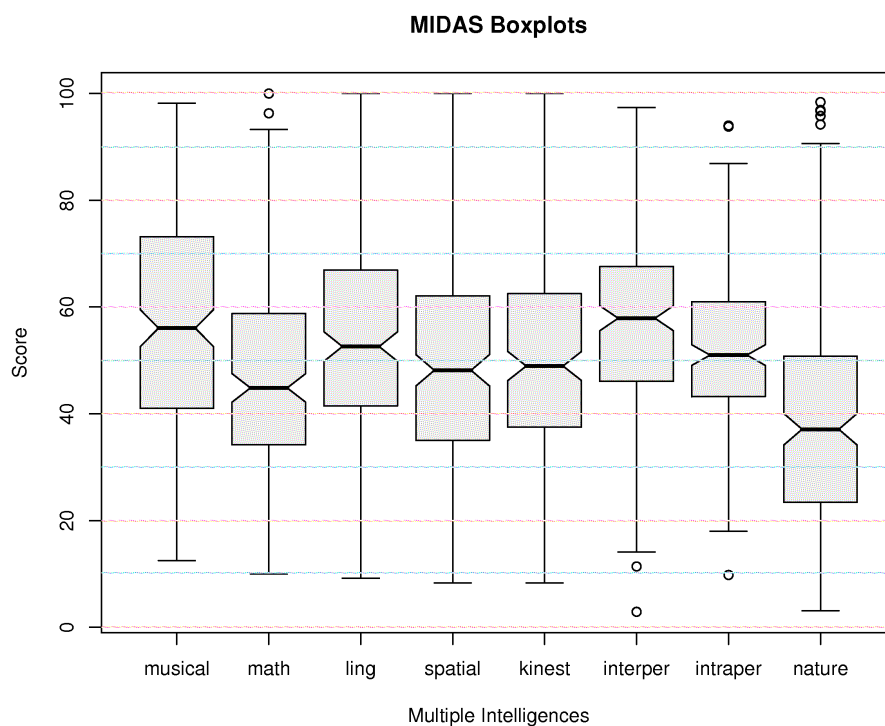

The median score and 90% confidence interval for the Naturalist intelligence falls into the LOW ranking. On average, students in this study display higher scores in musical and interpersonal intelligences. They display the lowest median scores in logical/mathematical and naturalist intelligences.

The range of multiple intelligence scores (as displayed by the whiskers) span nearly the entire range 10 to 100 for all but two of the intelligences. Intrapersonal intelligence shows the tightest span with scores ranging from about 20 to just under 90. The naturalist intelligence has 75% (box and lower whisker) of its data at or below the 50 mark. A number of intelligences show outliers (1.5 times the interquartile range found by subtracting Q3 from Q1, see Table 4.35), these are math, interpersonal, intrapersonal, and naturalist

Table 4.35: MIDAS: Boxplot Summary

	min	Q1	median	90% interval	Q3	max
musical	12.5	40.95	56.05	51.9-60.7	73.2	98.2
math	10	34.2	44.85	43.4-47.5	58.8	100
linguistic	9.2	41.33	52.6	51.3-56.8	67	100
spatial	8.3	35	48.15	45.3-50.8	62.3	100
kinest	8.3	37.5	48.95	46.7-51.1	62.5	100
interper	2.9	46.1	57.9	55.6-59.8	67.9	97.4
intra per	9.8	43.2	51	49.0-54.0	61	94
nature	3.1	23.4	37.1	33.1-39.1	51.2	98.4

intelligences.

Table 4.36 gives the descriptive statistics for the MIDAS intelligences. Coefficients of variation (measures of variability) are nearly the same for most of the intelligences, except for intrapersonal which shows the least variability (28%), and naturalist which has the greatest variability in data (54%). All intelligences show a low skewness and low excess kurtosis, well within the customary ± 1 threshold for assuming approximate normality. This assumption is confirmed in Figure 4.18 which depicts the Q-Q plots of each intelligence. Data that are normally distributed will be located along a straight line $y=x$ with only minor variations [63].

Interpretations of curve shapes are given in Table 4.37. The 'S'-shaped musical qqplot suggests that this distribution has short tails at either end. The upward cup-shaped qqplots for math, spatial, and especially naturalist suggest that these distributions are skewed to the right. The remaining qqplots are nearly perfectly linear suggesting that kinesthetic, linguistic, intrapersonal, and interpersonal intelligences are normally distributed. Figure 4.19 plots the histograms of all the MIDAS intelligences and reports the chi-square goodness-of-fit for the normal distribution. The histograms with the normal curve superimposed confirm

Figure 4.18: Normal Plots of MIDAS Multiple Intelligences

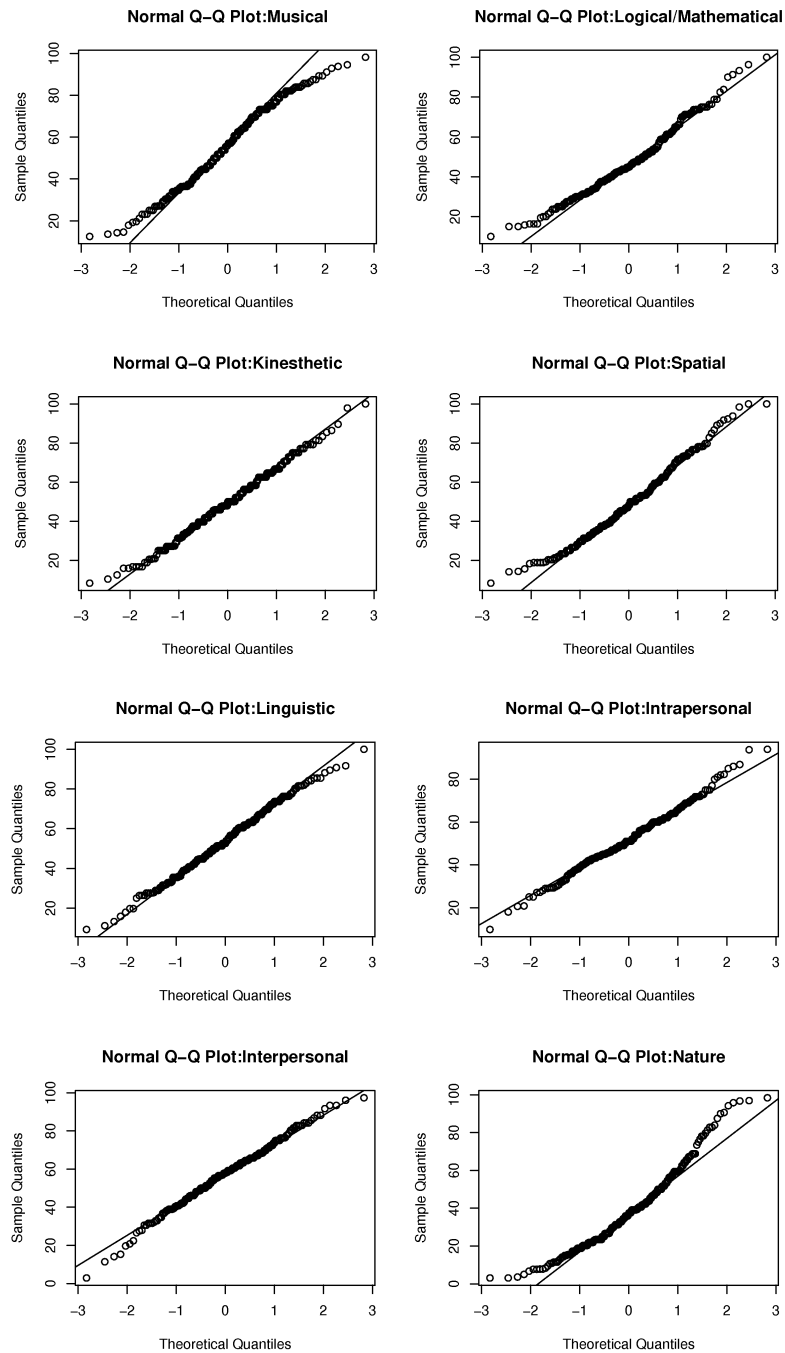

Table 4.36: Summary Stats for MIDAS

Summary Statistics, using the observations 1–212

Variable	Mean	Median	Minimum	Maximum
musical	56.0264	56.0500	12.5000	98.2000
kinest	49.2991	48.9500	8.30000	100.000
math	47.2868	44.8500	10.0000	100.000
spatial	49.1670	48.1500	8.30000	100.000
ling	53.9472	52.6000	9.20000	100.000
interper	57.0976	57.9000	2.90000	97.4000
intraper	52.1094	51.0000	9.80000	94.0000
nature	39.1038	37.1000	3.10000	98.4000

Variable	Std. Dev.	C.V.	Skewness	Ex. kurtosis
musical	19.7325	0.352201	−0.0810006	−0.856470
kinest	17.7523	0.360095	0.109454	−0.245587
math	17.3148	0.366166	0.490965	0.0126883
spatial	19.3178	0.392901	0.368171	−0.361722
ling	17.6268	0.326743	−0.0225751	−0.414975
interper	16.8671	0.295409	−0.227260	0.175089
intraper	14.3700	0.275766	0.153680	0.257901
nature	21.2177	0.542601	0.723745	0.139663

the qqplot diagnostics given above.

4.1.3 Relationship between the Technology Acceptance Model and Multiple Intelligences (TAM ~ MIDAS)

Davis’s TAM allows that external variables may influence a user’s perceived ease of use and usefulness of a technology, and that these influences will ultimately affect the actual system usage. Educators maintain that multiple intelligences influence how students learn

Figure 4.19: MIDAS Intelligences Histograms

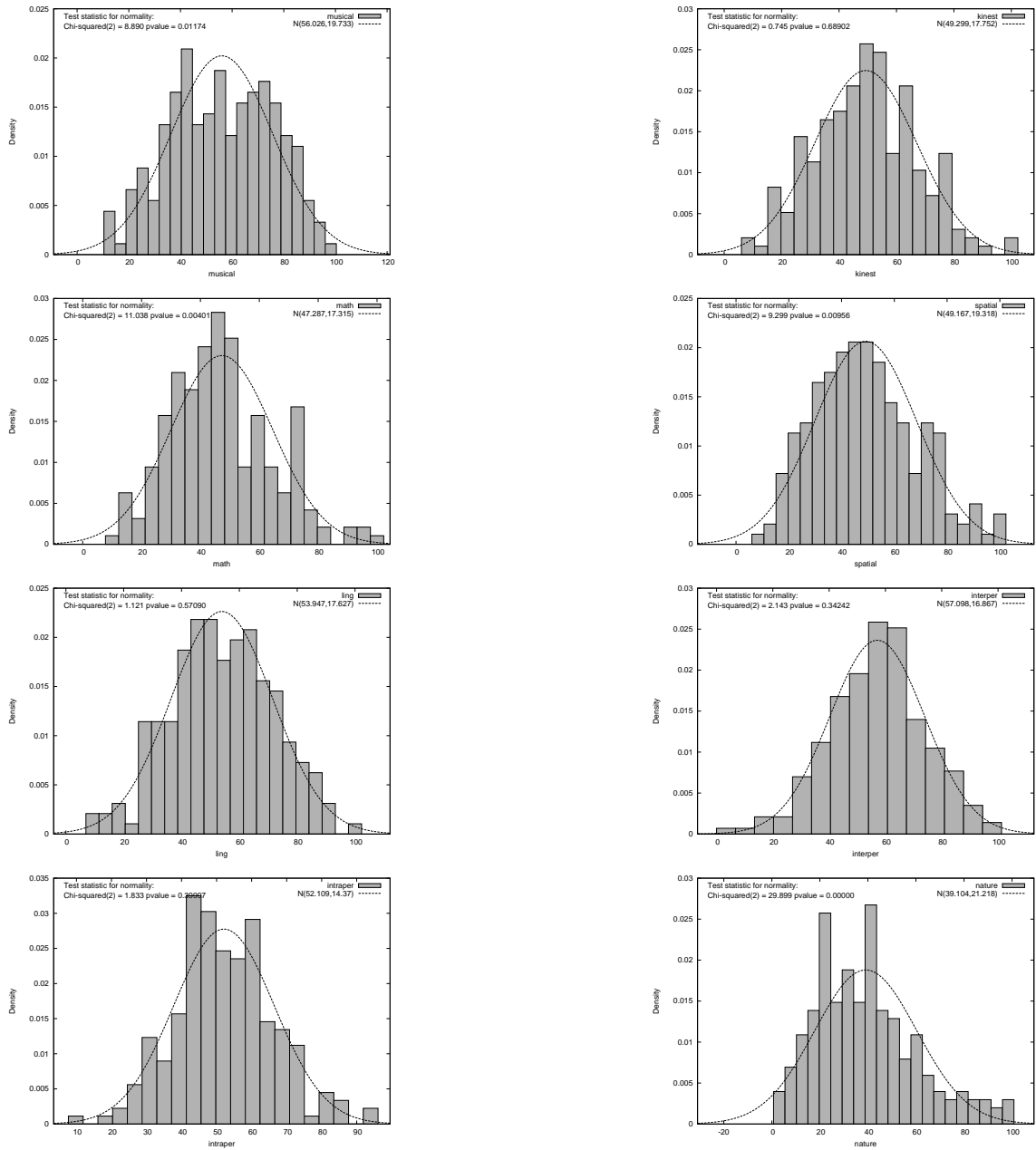

Table 4.37: Quantile-Quantile Plot Diagnostics

Description of Point Pattern	Possible Interpretation
all be a few points fall on a line	outliers in the data
left end of pattern is below the line; right end of patter is above the line	long tails at both ends of the data distribution
left end of patter in above the line; right end of pattern is below the line	short tails at both ends of the data distribution
curved pattern with slope increasing from left to right	data distribution is skewed to the right
curved pattern with slope decreasing from left to right	data distribution is skewed to the left
staircase patter (plateaus and gaps)	data have been rounded or are discrete

This table has been taken from http://support.sas.com/documentation/cdl/en/procstat/59629/HTML/default/procstat_univariate_sect040.htm

best and work diligently to tailor lessons and activities to accommodate these intelligences. The goal of this study was to determine if students' intelligences as defined by Gardner play an equally important role in determining whether they are willing to use/adopt an elearning technology, in this case Moodle. To address this question the following hypotheses are put forward.

Hypotheses 1, 2, 5, 6, 11, 12, 13, 14: There is a negative relationship between each of bodily/kinesthetic (kinest), musical/rhythmic (musical), interpersonal (interper), and naturalist (nature) intelligences and the perceptions that a learning management system (MOODLE) is either useful (PU) or easy to use (PEU). [92]

Hypotheses 3, 4, 7, 8, 9, 10, 15, 16: There is a positive relationship between each of logical/mathematical (math), intrapersonal (intraper), visual/spatial (spatial), and verbal/linguistic (ling) intelligences and the perceptions that a learning management system (MOODLE) is either useful (PU) or easy to use (PEU). [92]

As stated earlier, the objective of regression analysis is to establish whether or not a relationship exists between variables and to determine the nature and strength of that relationship. As such, multiple linear regression will be used to test the validity of these hypotheses.

Figure 4.20 shows a multiplot of each TAM factor as it relates to each of the major MIDAS intelligence factors. It is immediately evident that there is little correlation between either set of constructs. The largest correlation, $r = 0.15$, may be found between the factors PEUmean and musical intelligence. Most of the remaining correlations fall well below 0.10 with the five smallest values being nearly zero. What is even more disconcerting is the initial LOESS line drawn for each pair of factors. Specifically, the lines drawn for PEUmean and PUmean between each of the MIDAS intelligences is essentially a horizontal line (a slope of zero) with no noticeable curvature. The implication is that the distributions are uniform for each of these data sets. Recall uniform distributions are those used to describe data sets for which a linear regression is not well suited [113].

Table 4.38 gives the results of the regression of MIDAS intelligences against PEUmean. Two factors are significant, logic/math (math) and intrapersonal (intraper), however, their coefficients are tiny. Checking the confidence intervals in Table 4.39 shows that each interval for these factors contains 0 as a possibility, rendering the coefficient useless. Testing the utility of the model [113] with null hypothesis:

$$\begin{aligned}
 H_0 : \beta_0 &= \beta_{music} = \beta_{math} = \beta_{kinest} = \beta_{spatial} \\
 &= \beta_{ling} = \beta_{interper} = \beta_{intraper} = \beta_{nature} = 0
 \end{aligned}
 \tag{4.2}$$

Figure 4.20: TAM Factors versus MIDAS Intelligences

(a) 4 MIDAS intelligences versus TAM factors

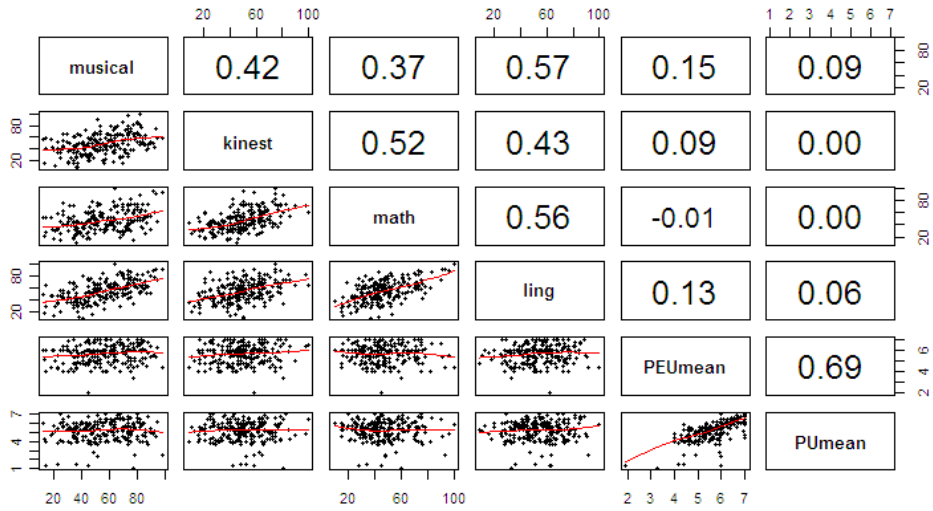

(b) 4 MIDAS intelligences versus TAM factors

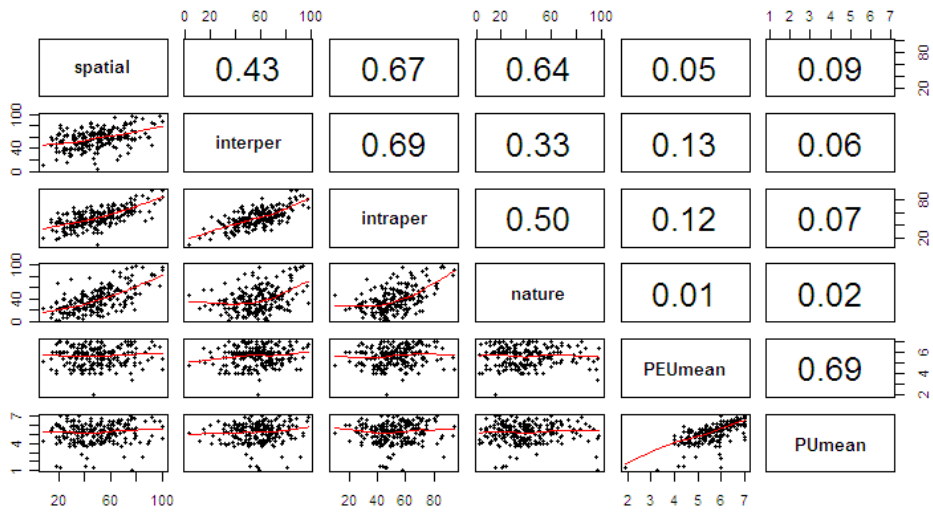

yields an $F(8,203)=1.756389$ for the model with a $p\text{-value}=0.087544$. Hence one cannot reject the null hypothesis at the $\alpha = 0.05$ level and must assume the values are zero. In addition, the adjusted coefficient of determination for the regression is itself nearly zero $R^2 = 0.03$, implying that the model does little or nothing to explain variance of the dependent variable.

One possible source of difficulty may be in the multicollinearity of the independent variables. Multicollinearity may confound the interpretation of variables and has the potential of limiting the coefficient of determination [63]. If there is a strong correlation between variables, coefficients may be inappropriately sized and may even carry the wrong sign. Table 4.40, reports the variance influence factors (VIF) for each of the multiple intelligence factors. None of the factors of the values approach the critical value of 10. Hence, even though there exists a correlation between some of the intelligences, these correlations do not pose a threat to the determination of the regression equation.

PUmean gives a very similar story. Table 4.41 displays the results for the multiple regression of the MIDAS intelligences against PUmean. In this case, none of the independent variables are significant at either the $\alpha = 0.05$ or $\alpha = 0.10$ levels. The null hypothesis stated in Equation 4.2, also cannot be rejected and one is forced to conclude that the betas for all coefficients are zero. Further confirmation for this conclusion is given in the table of confidence intervals for the variables, all of which straddle 0.0, see Table 4.42. Checking for the possible influence of multicollinearity reveals little, as none of the variables are unduly correlated ($VIF \geq 10$), see Table 4.43. Finally, the adjusted coefficient of determination of $R^2 = -0.003$ implies that this regression provides no useful information in determining outcomes of PUmean.

From this analysis it is determined that none of the sixteen hypotheses are supported. That is, that the null hypotheses for each of these factors ($\beta_{(TAM\ Factor, Multiple\ Intelligence)} = 0$) cannot be rejected.

Table 4.38: PEU~MIDAS: Regression

Model $PEU_{mean} \sim$ MIDAS intelligences: OLS, using observations 1–212
 Dependent variable: PEUmean

	Coefficient	Std. Error	<i>t</i> -ratio	p-value
const	4.95183	0.249563	19.8420	0.0000
musical	0.00494122	0.00382590	1.2915	0.1980
kinest	0.00251457	0.00440924	0.5703	0.5691
math	-0.0179712	0.00704540	-2.5508	0.0115
spatial	-0.000315035	0.00515463	-0.0611	0.9513
ling	0.00181543	0.00548122	0.3312	0.7408
interper	-0.00161463	0.00574014	-0.2813	0.7788
intraper	0.0203361	0.00921954	2.2058	0.0285
nature	0.000508236	0.00388535	0.1308	0.8961
Mean dependent var	5.572665	S.D. dependent var	0.882138	
Sum squared resid	153.5642	S.E. of regression	0.869755	
R^2	0.064736	Adjusted R^2	0.027879	
$F(8, 203)$	1.756389	P-value(F)	0.087544	

Table 4.39: PEU~MIDAS: Confidence Intervals

$$t(203, 0.025) = 1.972$$

Variable	Coefficient	95% confidence interval	
const	4.95183	4.45976	5.44390
musical	0.00494122	-0.00260238	0.0124848
kinest	0.00251457	-0.00617921	0.0112084
math	-0.0179712	-0.0318628	-0.00407967
spatial	-0.000315035	-0.0104785	0.00984845
ling	0.00181543	-0.00899200	0.0126229
interper	-0.00161463	-0.0129326	0.00970332
intraper	0.0203361	0.00215775	0.0385144
nature	0.000508236	-0.00715259	0.00816906

Table 4.40: PEU~MIDAS: Multicollinearity

Intelligence	VIF
musical	1.590
kinest	1.709
math	4.151
spatial	2.766
ling	2.604
interper	2.615
intraper	4.896
nature	1.896

Table 4.41: PU~MIDAS: Regression

Model $PU_{mean} \sim$ MIDAS Intelligences: OLS, using observations 1–212
 Dependent variable: PUmean

	Coefficient	Std. Error	<i>t</i> -ratio	p-value
const	4.74703	0.319558	14.8550	0.0000
musical	0.00551262	0.00489895	1.1253	0.2618
kinest	−0.00525394	0.00564590	−0.9306	0.3532
math	−0.0146245	0.00902142	−1.6211	0.1066
spatial	0.00989651	0.00660034	1.4994	0.1353
ling	−0.00312432	0.00701853	−0.4452	0.6567
interper	0.000351412	0.00735008	0.0478	0.9619
intraper	0.0142962	0.0118053	1.2110	0.2273
nature	−0.00136933	0.00497507	−0.2752	0.7834
Mean dependent var	5.134842	S.D. dependent var		1.111566
Sum squared resid	251.7840	S.E. of regression		1.113694
R^2	0.034228	Adjusted R^2		−0.003832
$F(8, 203)$	0.899308	P-value(F)		0.518017

Table 4.42: PU~MIDAS: Confidence Intervals

$$t(203, 0.025) = 1.972$$

Variable	Coefficient	95% confidence interval	
const	4.74703	4.11695	5.37711
musical	0.00551262	-0.00414672	0.0151720
kinest	-0.00525394	-0.0163861	0.00587818
math	-0.0146245	-0.0324122	0.00316320
spatial	0.00989651	-0.00311751	0.0229105
ling	-0.00312432	-0.0169629	0.0107143
interper	0.000351412	-0.0141409	0.0148437
intraper	0.0142962	-0.00898063	0.0375730
nature	-0.00136933	-0.0111788	0.00844011

Table 4.43: PU~MIDAS: Variance Influence Factors

Intelligence	VIF
musical	1.590
kinest	1.709
math	4.151
spatial	2.766
ling	2.604
interper	2.615
intraper	4.896
nature	1.896

4.2 Discussion

Table 4.1 gives a list of the results from this study. In addition to the eight major scales, the MIDAS provides a number of subscales for each of the individual multiple intelligences. Plots and correlations for each of these subscales as they relate to the TAM factors, PEUmean and PUmean, may be found in Appendix K. As with the major intelligence factors, there is no support for hypotheses 1-16 stated above that may be found in the subscales.

One explanation for the poor regression results may be the presence of confounding factors. Two likely possibilities may be gender and ethnicity. Appendix J gives coplots of the PEUmean and PUmean versus the MIDAS intelligences broken out by both. The scatterplots are much as they were in Figure 4.20 with no (non-horizontal) linearity evident. Regressions on these subsets (results omitted) are as they were for the entire sample and provide no new information.

Forward and backward regression techniques were also applied to the sample. There was no suitable subset of MIDAS intelligences found by either method. Moreover, the sensitivity of the analyses was very high. Inclusion or omission of a single variate dramatically altered the regression results. Since these techniques often are strongly dependent upon which variates one begins with and the order in which variates are entered, no further investigation in this direction will be pursued [63, 113].

Overall, analysis indicates that the TAM premises are supported by this study. Likewise, the MIDAS assessment instrument performed within expectations. The connection between the two theories, however, was non-existent. Conclusions and recommendations drawn from this research will be explored in the next chapter.

CHAPTER V

CONCLUSIONS AND RECOMMENDATIONS

The results from this study are surprising. The literature as well as informal conversations with educators supported the supposition that multiple intelligences would influence how a student perceived using and ultimately adopt an elearning technology. Certainly most educators have come to agree, and research confirms, that the best way to engage a student in the learning process is to provide activities and lessons that honor student uniquenesses and personal learning preferences which are based on a student's multiple intelligences and learning styles [162]. So it should follow that an elearning environment that could only adequately match a few of these intelligences (e.g. intrapersonal, logic/mathematical, and linguistic), and is not yet mature enough to completely accommodate others (e.g. kinesthetic, musical, interpersonal, spatial, naturalist) must necessarily appeal to some students but be less so for others. However, such a position cannot be supported here.

Students who participated in this study may be truly called "Digital Natives" [141]. They have grown up with technology (TV, computers, and the Internet) and carry it with them wherever they go (cell phones, MP3 players, USB thumbdrives). Over 75% of the students in this study reported using a computer on a daily basis. Over 90% use the Internet for various forms of entertainment, email, and social networking. These students do not perceive any difference between using the Internet for non-academic versus academic activities. Yet most lack the experience to make the distinction (fewer than 40% use the

computer for academic purposes).

Had this study been conducted earlier in the history of elearning development, results may have been different. Yet one might argue that at such a time, comfort or fear of using computers and the Internet would have confounded the results and masked what is at the heart, specifically the attitude toward using and the adoption of the elearning technology (e.g the learning management system Moodle). Two-thirds of the students surveyed consider themselves expert in the use of computers and the Internet. Hence the hurdles of the technology itself are not at issue, rather the adoption of the new elearning application, Moodle, is clearly the focus. With fewer than 30% of the students surveyed having taken more than single course that had an online component, most still felt that they would be willing to adopt the learning management system, Moodle. Indeed, after the presentation was given on Moodle, many students began pressing their instructors as to why they were not using the technology as part of their current coursework.

The results of this study strongly suggest that the model presented earlier (see Figure 5.1) be amended and that the position of computer/technology as delivery agent be moved into the section labeled environment. Students, independent of their multiple intelligence profiles, overwhelming perceived Moodle as easy to use and useful. They did not see learning with this tool as any different than any of the other myriad applications of computers and Internet technologies that they were already employing on a daily basis. One is reminded of L. Frank Baum's story of the Wizard of Oz. When Dorothy, the Lion, Scarecrow, and Tinman first met the Wizard they were reluctant to enter the chamber and were frightened by the technology. But once they "looked behind the curtain" the technology no longer was of any concern and they could look to the Wizard as teacher and mentor. So it is with the elearning system Moodle. Many of the students have long before come to terms with computers and Internet technologies. The technology is no longer the bug-a-boo that it might have been. Hence the technology itself is moved from the key role of delivery agent

Figure 5.1: Revised Learning Systems Model

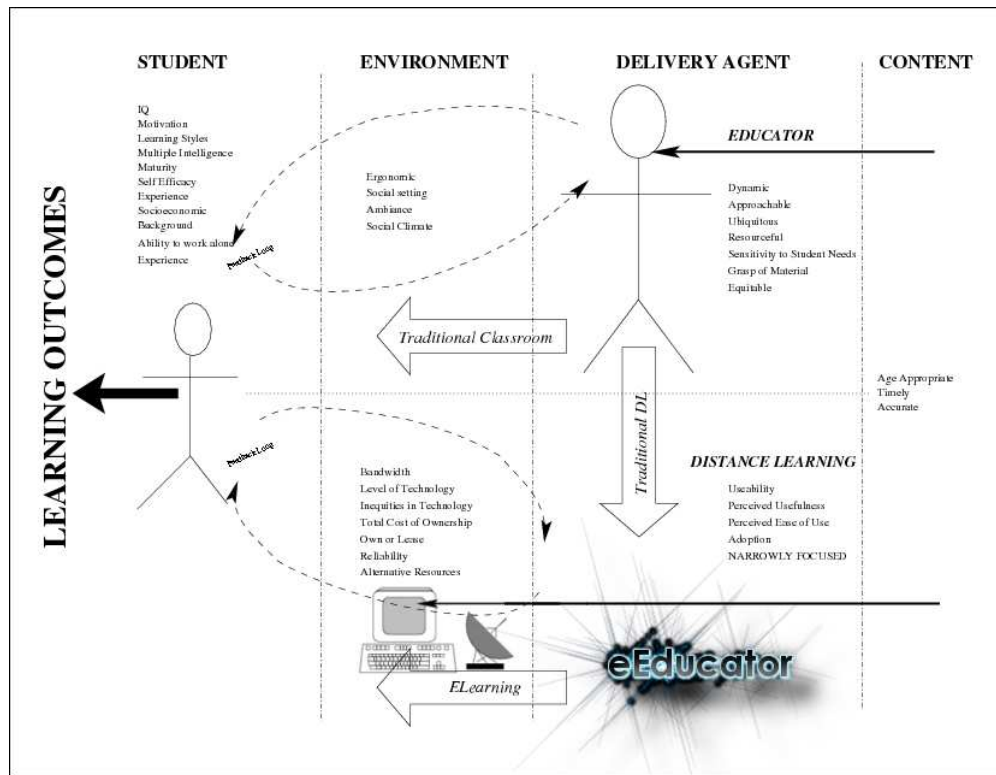

and is positioned as part of the environment, the backdrop from which learning can begin. This movement creates a void that must be filled by would-be e-learning educator. This is a crucial message to e-educators (those who would use elearning as a vehicle for instruction) because it demands that they themselves rise above and employ elearning technologies for more than the posting of class notes and simple presentations. Moreover, e-educators need to adjust their teaching methods to engage students online just as must be done in a traditional face-to-face classroom for the indication is that the students are waiting and ready for this next step.

Were this study to be repeated one might choose a population with more experience actually using an elearning technology or learning management system. As was noted, even though the school system selected had years earlier adopted Moodle as its Internet based

learning management system, very few teachers were actually using the tool at the time the study was conducted. Consequently most of what students knew about elearning and Moodle, in particular, came from the presentation that was given for the purposes of this work. This fact may be the greatest source of bias, especially if students perceived the follow-up TAM survey as an impromptu quiz over the material they had just learned. A study that focused on non-traditional adult learners or those already regularly using elearning technologies may provide more insight into how multiple intelligences may impact elearning adoption.

Other extensions of this work may include evaluating differing types of online learning management systems and the degree of alignment between a student's multiple intelligences, perceptions of use and usefulness, and the degree of flexibility, quality, and type of interactivity and/or lessons that they provide. One might speculate that purely text based systems would be less attractive than LMSs that have a high degree of interactivity and multimedia connections. One might also add the degree of teacher involvement into the mix. Such as, whether the e-learning class is completely devoid of face-to-face interaction on one end of the spectrum to completely blended environments in which students work independently at their stations but have an instructor on hand to respond to questions for which the online material is vague or insufficient (a model many certification academies and credit recovery programs currently employ) on the other.

Given the growth of the elearning market, the growing number of traditional and non-traditional students, the emphasis on life-long learning, and the potential impact elearning has on business strategy ¹, perhaps one of the most important observations of this study is the lack of involvement/experience teachers and students had with elearning systems. With the trend to move more learning online and earlier in a student's career [74], earlier experiences with elearning systems would help to prepare students for the rigors and work load

¹See also Chief Learning Officer Magazine at <http://www.clomedia.com>

associated with this kind of learning. In addition, teachers (especially “digital immigrants” as described by Prensky [141]) might consider building skills and comfort using elearning systems and other online systems (referred to as “Web 2.0” skills [41]) for the benefit of their students. Likewise colleges and universities, who stand to benefit from elearning initiatives, may choose to train new teachers in the use of learning management systems and associated technologies. In all, it will be interesting to watch how elearning evolves over the next decade and what the next generation of distance learning technologies will bring.

BIBLIOGRAPHY

- [1] *Changing Trends in Corporate Education: Impacting University Education?* Proceedings of the 16th Annual Conference of the International Academy for Information Management, 2001.
- [2] *Telematic Education in Informatics: A Case Study of the Pitfalls and the Challenges.* Proceedings of the 16th Annual Conference of the International Academy for Information Management, 2001.
- [3] Lee Adkins. Undergraduate econometrics using Gretl. an ebook at <http://www.learneconometrics.com/class/4213/gretl/ebook.pdf>, 2006.
- [4] Said S. Al-Gahtani and Malcolm King. Attitudes, satisfaction and usage: Factors contributing to each in the acceptance of information technology. *Behaviour & Information Technology*, 18(4):277–297, Jul-Aug 1999.
- [5] anon. Distance learning. Issues and Controversies On File, Mar 2001. FACTS.com, Cleveland Heights High School Library, Cleveland Heights, OH. April 28, 2005 <http://www.2facts.com>.
- [6] anon. K-12 science education: Critical to our nation's future science and engineering, workforce, national security, and more. Technical report, National Science Teachers Association, 2004. Work Force Report.
- [7] J. B. Arbaugh and Rebecca Duray. Instructor behaviors, student satisfaction, and learning in web-based mba courses. In *Decision Sciences Institute 2001 Proceedings*, 2001.

- [8] A. Bandura. Self-efficacy mechanism in human agency. *American Psychologist*, 37:122–147, 1982.
- [9] D’Arcy Becker and Meg Dwyer. The impact of student verbal/visual learning style preference on implementing groupware in the classroom. *JALN*, 2:61–69, 1998.
- [10] R. M. Bernard, P. C. Abrami, Y. Lou, E. Borokhovski, A. Wade, L. Wozney, P. A. Wallet, M. Fiset, and B. Huang. How does distance education compare with classroom instruction? a meta-analysis of the empirical literature. *Review of Educational Research*, 74:379, 2004.
- [11] W. D. Berry. Understanding regression assumptions. In Diane S. Foster, editor, *University Series on Quantitative Applications in the Social Sciences*, number 92 in 07-092. Sage, Newbury Park, CA, 1993.
- [12] Genie Black. A comparison of traditional, online and hybrid methods of course delivery. *Journal of Business Administration Online*, 1(1), Spring 2002.
- [13] Kimberly Dawn Blum. Gender differences in asynchronous learning in higher education: learning styles, participation barriers and communication patterns. *JALN*, 3(1), May 1999.
- [14] Alfred Bork. What is needed for effective learning on the web? *Educational Technology & Society*, 3(4):139–144, 2001.
- [15] Phil Britt. Elearning on the rise. *EContent*, 27(11):36, Nov 2004.
- [16] M. J. Brosnan. Modeling technophobia: A case for word processing. *Computers in Human Behavior*, 15(2):105–121, Mar 1999.

- [17] Irwin T. J. Brown. Individual and technological factors affecting perceived ease of use of web-based learning technologies in a developing country. *The Electronic Journal on Information Systems in Developing Countries*, 9(5), 2002.
- [18] Cynthia P. Cadieux. *Variables Associated with a Sense of Classroom Community and Academic Persistence in an Urban Community College Online Setting*. PhD thesis, Old Dominion University, 2002.
- [19] Mick Campion. The supposed demise of bureaucracy: Implications for distance education and open learning ? more on the post-fordism debate. *Distance Education*, 16:192, 1995.
- [20] Mick Campion and William Renner. The supposed demise of fordism: Implications for distance education and higher education. *Distance Education*, 13:7, 1992.
- [21] Vincenza Carchiolo, Alessandro Longheu, and Michele Malgeri. Adaptive formative paths in a web-based learning environment. *Educational Technology & Society*, 5(4):64–75, 2002.
- [22] Vincenza Carchiolo, Alessandro Longheu, and Michele Malgeri. Adaptive formative paths in a web-based learning environment. *Educational Technology and Society*, 5(4), 2002.
- [23] Bobbie Chan. A study of the relationship between tutor’s personality and teaching effectiveness: Does culture make a difference? *International Review of Research in Open and Distance Learning*, 1:1–25, Oct 2002. ISSN: 1492-3831.
- [24] Mackie Chase, Leah Macfadyen, Kenneth Reeder, and Jorg Roche. Intercultural challenges in networked learning: Hard technologies meet soft skills. *First Monday*, 7(8):1–17, 2002.

- [25] Eduardo O. C. Chaves. Distance teaching and technology-mediated learning: A brief discussion. In *Proceedings of the International Congress on Engineering and Computer Education*, August 1999. Invited paper for ICECE99.
- [26] Chih-Ming Chen and Yi-Yun Chen. Learning performance assessment approach using learning portfolio for e-learning systems. pages 557–561. IEEE Computer Society, 2005.
- [27] D. Clark. Psychological myths in e-learning. *Medical Teacher*, 24(6):598–604, 2002.
- [28] Douglas Clark, editor. *A Long-Awaited Conversation: Dialogue to Bridge the High-Tech/High-Touch Gap In Early Childhood Workforce Preparation and Professional Development*. The Child Care Bureau Administration on Children, Youth and Families, Administration for Children and Families, U.S. Department of Health and Human Services, 2004. Hosted by The Center for Early Childhood Leadership of National-Louis University.
- [29] Susan Codone. *An E-Learning Primer*. Raytheon Interactive, Pensacola, FL, Nov 2001.
- [30] Frank Coffield, David Moseley, Elaine Hall, and Kathryn Ecclestone. Learning styles and pedagogy in post-16 learning: A systematic and critical review. Technical report, Learning & skills research centre, 2004.
- [31] Geoff Collier, Harry Piccariello, and Robby Robson. A digital rights management ecosystem model for the education community. ECAR (forthcoming), May 2004.

- [32] Catherine Collins et al. Correlates of end-user performance and satisfaction with the implementation of a statistical software package. In *Proceedings of the 10th Australasian Conference on Information Systems*, 1999.
- [33] A. Cottrell and R. Lucchetti. *Gretl User's Guide*, 2007.
- [34] Davis F. D. and V. Venkatesh. A critical assessment of potential measurement biases in the technology acceptance model: three experiments. *International Journal of Human-Computer Studies*, 45:19–45, 1996.
- [35] David B. Dahl. *xtable: Export tables to LaTeX or HTML*, 2008. R package version 1.5-4.
- [36] Barbara J. Daley, Karen Watkins, Saundra Wall Williams, Bradley Courtenay, and Mike Davis. Exploring learning in a technology-enhanced environment. *Educational Technology & Society*, 4(3):126–138, 2001.
- [37] F. Davis, R. Bagozzi, and P. Warshaw. User acceptance of computer technology: a comparison of two theoretical models. *Management Science*, 35(8):982–1003, 1989.
- [38] F. D. Davis. User acceptance of information technology: System characteristics, user perceptions and behavioral impacts. *International Journal of Man-Machine Studies*, 38(3):475–488, 1993.
- [39] Fred D. Davis. Perceived usefulness, perceived ease of use, and user acceptance of information technology. *MIS Quarterly*, pages 319–340, September 1989.
- [40] Geoffrey N. Dick, Thomas L. Case, and O. Maxie Burns. Adopting distance education-what do the students think? In *Proceedings of the 16th Annual Conference of the International Academy for Information Management*, 2001.

- [41] D. DiNucci. Fragmented future. *Print*, 53(4):32, 1999.
- [42] Peter J. Dirr. *Distance and Virtual Learning in the United States*, chapter 3, pages 23–48. Commonwealth of Learning, Vancouver, BC, Canada, 1999. ED 432 668.
- [43] Kelly Driscoll. E-portfolios. *SchoolArts: The Art Education Magazine for Teachers*, 107:55, October 2007.
- [44] Rodger Faherty. Corporate e-learning. Dublin Institute of Technology, School of Computing Research Paper (ITSM), DIT, Dublin 8, Ireland, 2003.
- [45] Nick Farnes. Modes of production: Fordism and distance education. *Open Learning: The Journal of Open and Distance Learning*, 8:10, 1993.
- [46] Andrew Feenberg. Distance learning: promise or threat? *Academe*, 1:26–31, Sept-Oct 1999.
- [47] Tino Fenech, Dennis Charles, and Bill Merrilees. Using perceived ease of use and perceived usefulness to predict acceptance of the world wide web. *Computer Networks and ISDN Systems*, 30(1-7), 1998.
- [48] M. Fishbein and I. Ajzen. *Understanding Attitudes and Predicting Social Behavior*. Prentice-Hall, Englewood Cliffs, NJ, 1980.
- [49] K. Frankola. The e-learning taboo: High dropout rates in online courses. *Syllabus*, 14(11):14–16, 2001.
- [50] Scott Fredrickson. Behind the curve in teacher preparation: how schools and colleges of education should be preparing their preservice teachers to teach using instructional technology. *Journal of Information Technology Impact*, 1(2):73–80, 1999. <http://www.jiti.com/v1n2/fredrickson.html>.

- [51] Bruce Frey. *Statistics Hacks*. O’Rielly, Sebastopol, CA, 2006.
- [52] Norm Friesen. Three objections to learning objects and e-learning standards. *Online Education Using Learning Objects*, pages 59–70, 2004.
- [53] David J. Fritzsche. On the relationships of learning style, perceived learning, and performance in an experiential learning environment. In *Computer Simulation and Learning Theory*, volume 3. Austin: The University of Texas at Austin, 1977.
- [54] Rodney D. Fulton. *Creating Environments for Effective Adult Learning*, chapter 2:A Conceptual Model for Understanding the Physical Attributes of Learning Environments, pages 13–22. Number 50 in *New Directions For Adult And Continuing Education*. Jossey-bass Inc. Publishers, San Francisco, CA, 1991.
- [55] Christina Gardner and Donald L. Amoroso. Development of an instrument to measure the acceptance of internet technology by consumers. In *Proceedings of the 37th Hawaii International Conference on System Sciences*, 2004.
- [56] H. Gardner. *Intelligence Reframed: Multiple Intelligences for the 21st Century*. Basic Books, 1999.
- [57] H. Gardner. Multiple intelligences after twenty years. *American Educational Research Association*, 21:2003, April 2003. Chicago, Illinois.
- [58] Howard Gardner. *Frames of Mind*. Basic Books, New York, NY, tenth-anniversary edition, 1993.
- [59] Howard Gardner. *The Disciplined Mind*. Penguin Books, New York, NY, 2000.
- [60] O. P. Gobee. Learning objects cannot be free of context; proposal for an alternative format to achieve reusability. In *Proceedings of ED-MEDIA*. AACE, 2005.

- [61] Robert Godwin-Jones. Emerging technologies learning objects: Scorn or SCORM? *Language Learning and Technology*, 8(2):7–12, 2004.
- [62] Linda Grubbs. Get smart: The pluses and minuses of e-learning. *PC World*, 1:116–123, Nov 2000. evaluates online learning providers.
- [63] Joseph F. Hair Jr., Rolph E. Anderson, Ronald L. Tatham, and William C. Black. *Multivariate Data Analysis with Readings*. Macmillan Publishing Company, New York, NY, 3 edition, 1992.
- [64] Tracey Hall. Differentiated instruction. Wakefield, MA, National Center on Accessing the General Curriculum, 2002.
- [65] Morten T. Hansen and Bolko Von Oetinger. Introducing T-shaped managers: Knowledge management's next generation. *Harvard Business Review*, 2001.
- [66] Noriko Hara and Rob Kling. Students' distress with a web-based distance education course: An ethnographic study of participants' experiences. *Turkish Online Journal of Distance Education*, 4(2), April 2003.
- [67] N. A. Heckert and James J. Filliben. *NIST Handbook 148:DATAPLOT Reference Manual, Volume 2:Let Subcommands and Library Functions*. National Institute of Standards and Technology, June 2003. Handbook Series.
- [68] N. A. Heckert and James J. Filliben. *NIST Handbook 148:DATAPLOT Reference Manual, Volume I: Commands*. National Institute of Standards and Technology, June 2003. Handbook Series.
- [69] Marilyn A. Hirth. Teaching via a distance learning network:a primer for beginners. *ED-TECH Review*, Spring/Summer:24–27, 1993.

- [70] H. Wayne Hodgins. The future of learning objects. In Jack R. Lohmann and Michael L. Corradini, editors, *Proceedings of the 2002 eTEE Conference*, volume P1, pages 76–82, Davos, Switzerland, August 2002. Article 11.
- [71] G. Hofstede. *Culture's Consequences*. Sage, London, 1980.
- [72] Kian-Sam Hong, Kwok-Wing Lai, and Derek Holton. Students' satisfaction and perceived learning with a web-based course. *Educational Technology & Society*, 6(1):1–15, 2003.
- [73] Kian-Sam Hong, Abang Ahmad Ridzuan, and Ming-Koon Kuek. Students' attitudes toward the use of the internet for learning: A study at a university in Malaysia. *Journal of Educational Technology & Society*, 6(2):45–49, April 2003.
- [74] Scott L. Howell, Peter B. Williams, and Nathan K. Lindsay. Thirty-two trends affecting distance education: An informed foundation for strategic planning. *Online Journal of Distance Learning Administration*, 6(3), Fall 2003. State University of West Georgia, Distance Education.
- [75] Echo Huang. Toward an understanding of web user behavior impact on web-based courseware acceptance and individual performance. <http://fox.rollins.edu/~lloyd/CWIS>.
- [76] Geoffrey Hubona. External variables and information technology usage behavior. Submitted to the *Journal of Management Information Systems*.
- [77] William G. Huitt. Teaching using distance learning. <http://chiron.valdosta.edu.whelitt/files/dlrnpap.html>, February 1994.

- [78] Yujong Hwang and Mun Y. Yi. Predicting the use of web-based information systems: Intrinsic motivation and self-efficacy. In *Eighth Americas Conference on Information Systems*, 2002.
- [79] Robert Irizarry. Self-efficacy & motivation effects on online psychology student retention. *United States Distance Learning Association Journal*, 16(12), December 2002.
- [80] Lloyd R. Jaisingh. *Statistics for the Utterly Confused*. McGraw-Hill, New York, NY, 2000.
- [81] Genevieve Marie Johnson. Student alienation, academic achievement, and WebCT use. *Educational Technology & Society*, 8(2):179–189, 2005.
- [82] R. A. Johnson and Michael A. Hignite. Applying the technology acceptance model to the WWW.
- [83] D. Jonassen. *Computers as Mindtools for Schools: Engaging Critical Thinking*. Prentice Hall, Inc, Saddle River, NJ, 2 edition, 2000.
- [84] Tom Jones. Options and considerations for distance education learner assessment and self-assessment. *Turkish Online Journal of Distance Education*, 3(3):1–7, July 2002.
- [85] Sam Kash Kachigan. *Multivariate Statistical Analysis: A Conceptual Introduction*. Radius Press, New York, NY, 2 edition, 1991.
- [86] Heather Kanuka and Liam Rourke. The impact of elearning on higher education. In *Information Technology Based Higher Education and Training, 2006. ITHET '06. 7th International Conference on*, pages 922–926, 2006.

- [87] Christina Keller and Lars Cernerud. Students' perceptions of e-learning in university education. *Journal of Educational Media*, 27(1-2):1–13, 2002.
- [88] Marcel Kerr, Kimberly Rynearson, and Kerr Marcus. Predicting student success in online courses: A new measure. In *Proceedings of the 10th Annual Distance Education Conference*, 2003.
- [89] William R King and Jun He. A meta-analysis of the technology acceptance model. *Information & Management*, 43:740–755, September 2006.
- [90] Mustafa Koc. Individual learner differences in web-based learning environments: From cognitive, affective and social-cultural perspectives. *Online Submission*, 6:12–22, October 2005.
- [91] Karel Kreijns, Paul A. Kirschner, and Wim Jochems. Identifying the pitfalls for social interaction in computer-supported collaborative learning environments. a review of the research. *Computers in Human Behavior*, 19(3):335–353, 2003.
- [92] Kemalatha Krishnasamy, Sai Peck Lee, and Selappan Palaniappan. *Effective Design Of E-learning Application Incorporating Multiple Intelligences*, volume 2911/2003 of *lecture notes in computer science*. Springer Berlin/Heidelberg, 2003. DOI 10.1007/b94517.
- [93] Carla Lane. Implementing multiple intelligences and learning styles in distributed learning/IMS projects. Technical report, The Education Coalition, 2000.
- [94] Judith C. Lapadat. Written interaction: A key component in online learning. *Journal of Computer-Mediated Communication*, 7:1–18, 2002.

- [95] Jae-Shin Lee, Hichang Cho, Geri Gay, Barry Davidson, and Anthony Ingrassia. Technology acceptance and social networking in distance learning. *Educational Technology and Society*, 6(2), 2003.
- [96] Paul Legris, John Ingham, and Pierre Collerette. Why do people use information technology? A critical review of the technology acceptance model. *Information & Management*, 40(3):191–204, January 2003.
- [97] Jane H. Leuthold. Is computer-based learning right for everyone? In *Proceedings of the Thirty-Second Annual Hawaii International Conference on System Science*, 1998.
- [98] Michael S. Lewis-Beck. Quantitative applications in the social sciences. In *Applied Regression*, 07-022. Sara Miller Mcune, Sage Publications, Inc, 1980.
- [99] A. Lian. Knowledge transfer and technology in education: Toward a complete learning environment. *Educational Technology & Society*, 3(3):13–22, 2000.
- [100] Kee-Sook Lim. Validation of the technology acceptance model with academic users. In *Proceedings - Annual Meeting of the Decision Sciences Institute*, pages 1402–1407, San Diego, CA, Nov 23-26 2002.
- [101] Julie Linden. The loneliness of the long-distance learner? perspectives on the creation of community within Syracuse university's master of library science-independent study degree program. In *EDUCOM '98*, pages 1–11, Oct 1998.
- [102] Lori K. Long and Robert D. Smith. The role of web-based distance learning in HR development. *Journal of Management Development*, 23(3):270–284, 2004.

- [103] Joe Luca and Mark McMahon. Assessing students' self-regulatory skills. In *Meeting at the Crossroads. Proceedings of the Annual Confence of the Australasian Society for Computers in Learning in Tertiary Education*, page 9, Dec 2001.
- [104] John Maindonald and John Braun. *Data Analysis and Graphics Using R: An Example-Based Approach*. Cambridge University Press, 2 edition, 2003. Cambridge Series in Statistical and Probabilistic Mathematics.
- [105] Yogesh Malhotra and Dennis F. Galletta. Extending the technology acceptance model to account for social influence: Theoretical bases and empirical validation. In *Proceedings of the 32nd Hawaii International Conference on System Sciences*, 1999.
- [106] George M. Marakas, Mun Y. Yi, and Richard D. Johnson. The multilevel and multifaceted character of computer self-efficacy: Toward clarification of the construct and an integrative framework for research. *Info. Sys. Research*, 9(2):126–163, 1998.
- [107] M. Martinez. High attrition rates in e-learning: Challenges, predictors, and solutions. *The eLearning Developers Journal*, 2003.
- [108] Luis L. Martins and Franz Willi Kellermanns. A model of business school students' acceptance of a web-based course management system. *Academy of Management Learning and Education*, 3(1):7–26, 2004.
- [109] Kathryn I. Matthew and Gita Varagoor. Student responses to online course materials. *Journal of Research on Technology in Education*, 33(5), Summer 2001.
- [110] D. Matthews. The origins of distance education and its use in the United States. *T.H.E. Journal (Technological Horizons In Education)*, 27, 1999.

- [111] Daniel J. McFarland and Kristina N. Cleary-Cannon. E-education: Mathematicians and scientists need only apply. In *International Conference On Advances in Infrastructure for Electronic Business, Science, and Education on the Internet*, L'Aquila, Italy, Aug 2001. SSGRR 2001.
- [112] Kim McMurtry. e-cheating: Combating a 21st century challenge. *T.H.E. journal*, 1:1–4, Jan 2004.
- [113] William Mendenhall and Terry Sincich. *A Second Course in Business Statistics: Regression Analysis*. Dellen Publishing Company, New York, NY, 4 edition, 1993.
- [114] M. David Merrill. First principles of instruction. *Educational Technology Research & Development*, 50(3):43–59, Sept 2002.
- [115] John Messing. Are we really doing students a favour? a study of the use of an electronic study guide in distance education. In *World Conference on Educational Multimedia and Hypermedia & World Conference on Educational Telecommunications Proceedings*, Freiburg, Germany, June 1998.
- [116] Marc Miller, R. Kelly Rainer, and J. Ken Corley. Predictors of engagement and participation in an on-line course. *Online Journal of Distance Learning Administration*, 6(1), 2003.
- [117] Marc D. Miller, R. Kelly Jr. Rainer, and Corley J. Ken. Predictors of engagement and participation in an on-line course. *Online Journal of Distance Learning Administration*, 6(1):1–15, Spring 2003. State University of West Georgia, Distance Education Center.
- [118] Ken Morse. Does one size fit all? exploring asynchronous learning in a multicultural. *Journal of Asynchronous Learning Networks*, 7(1):1–19, February 2003.

- [119] Brent Muirhead. Selecting a distance education school. *United States Distance Learning Association Journal*, 16(4):1–6, April 2002.
- [120] David Murphy. Instructional design for self-learning in distance education knowledge series. Technical report, The Commonwealth of Learning, Vancouver, BC, 2000.
- [121] Ted Nettelbeck and Carlene Wilson. Intelligence and IQ: What teachers should know. *Educational Psychology*, 25(6):609–630, 2005.
- [122] Mark Nichols. A theory for elearning. *Educational Technology and Society*, 6(2):1–10, 2003.
- [123] Kirstina Nink. Internet in German classrooms? an examination of variables influencing a teacher’s acceptance of the web. Master’s thesis, Georgetown University, 2003.
- [124] Kageni Njagi, Ron Smith, and Clint Isbell. Assessing students’ attitudes towards web-based learning resources. In *North America Web: The Web-based Learning Conference 2003*, 2003.
- [125] Ohio Department of Education. 2008-2009 school year report card. <http://www.ode.state.oh.us/reportcardfiles/2008-2009>, 2009.
- [126] Harold F. O’Neil. What works in distance learning. Technical report, University of Southern California/CRESST, Los Angeles, CA, Feb 2003. Deliverable to the Office of Naval research.
- [127] Jo Ann Oravec. Some influences of on-line distance learning on us higher education. *Journal of Further and Higher Education*, 27(1):89–103, Feb 2003. Routledge, part of the Taylor & Francis Group.

- [128] Jason W. Osborne and Elaine Waters. Four assumptions of multiple regression that researchers should always test. *Practical Assessment, Research, and Evaluation*, 8(2):5, 2002.
- [129] Karl Pajo. Individual characteristics and the adoption of technology in distance education. In *International Distance Education and Open Learning Conference Paper 33*, 2000. <http://www.com.unisa.edu.au/cccc/papers/refereed/paper33/Paper33-1.htm>.
- [130] Rena M. Palloff and Keith Pratt. *Lessons from the Cyberspace Classroom*. Jossey-Bass, San Francisco, California, 2001.
- [131] Cheng-Chang Pan, Stephen Sivo, and James Brophy. Students' attitude in a web-enhanced hybrid course: A structural equation modeling inquiry. *Journal of Educational Media & Library Sciences*, 41(2):181–194, December 2003.
- [132] Cheng-Chang Sam Pan, Stephen Sivo, James Brophy Ellison, and William Phillips. Is attitude contagious? a structural equation modeling approach. In *IMPACT 2003 Annual WebCT User Conference*, 2003.
- [133] Raymond Papp. Student learning styles & distance learning. In *Proceedings of the 16th Annual Conference of the International Academy for Information Management*. Proceedings of the 16th Annual Conference of the International Academy for Information Management, 2001.
- [134] C. Park. In other (people's) words: plagiarism by university students—literature and lessons. *Assessment & Evaluation in Higher Education*, 28:471–488, 2003.
- [135] Angie Parker. Identifying predictors of academic persistence in distance education. *United States Distance Learning Association Journal*, 17(1), 2003.

- [136] Linda Peters. Through the looking glass: Student perceptions of online learning. *The Technology Source*, September/October 2001.
- [137] Ronald A. Phipps. What's the difference? a review of contemporary research on the effectiveness of distance learning in higher education. Technical report, American Federation of Teachers, the National Education Association, and The Institute for Higher Education Policy, 1320 19th Street, NW, Suite 400 Washington, DC 20036, April 1999.
- [138] Ronald A. Phipps. How does technology affect access in postsecondary education? what do we really know? Technical Report NPEC 2004-831, National Postsecondary Education Cooperative, Jessup, MD, September 2004.
- [139] Alain Pinsonneault and Kenneth L. Kraemer. Survey research methodology in management information systems: an assessment. *Journal of Management Information Systems*, 10(2):75–105, 1993.
- [140] Pithamber R. Polsani. Use and abuse of reusable learning objects. *Journal of Digital Information*, 3(4):1–10, Feb 2003. Article No. 164.
- [141] Marc Prensky. Digital natives, digital immigrants. *On the Horizon*, 9(5), October 2001.
- [142] R. Development Core Team. *R: A Language and Environment for Statistical Computing*. R Foundation for Statistical Computing, Vienna, Austria, 2008. ISBN 3-900051-07-0.
- [143] Thomas C. Reeves. *Do Generational Differences Matter In Instructional Design?* Literature review, University of Georgia, 2008.

- [144] William Revelle. *psych: Procedures for Psychological, Psychometric, and Personality Research*, 2009. R package version 1.0-65.
- [145] Jennifer C. Richardson and Karen Swan. Examining social presence in online courses in relation to students' perceived learning and satisfaction. *JALN*, 7(1):68–88, 2003.
- [146] David F. Rico. ROI analysis of software process improvement, online education, and telecommuting. <http://davidfrico.com/rico03c.pdf>.
- [147] Tim S. Roberts. From distance education to flexible learning. In *Proceedings of the 16th Annual Conference of the International Academy for Information Management*, 2001.
- [148] J. Rosbottom, J. Crellin, and D. Fysh. A generic model for on-line learning. In *Proceedings of the 5th Annual SIGCSE/SIGCUE ITiCSE Conference*. Association for Computing Machinery, ACM Press, 2000. probably good for identifying generations of DL technology.
- [149] J. Ross and R. Schulz. Can computer-aided instruction accommodate all learners equally? *British Journal of Educational Technology*, 30:5–24, 1999.
- [150] Christine Rowat. It's all down to people, again. *Distribution Magazine*, August 2002.
- [151] Greville Rumble. Labour market theories and distance education I: Industrialisation and distance education. *Open Learning: The Journal of Open and Distance Learning*, 10:10, 1995.
- [152] P. M. Scanlon. Student online plagiarism: How do we respond? *College Teaching*, 51:161–166, 2003.

- [153] Ronald Schettkat. Differences in US-German time-allocation why do Americans work longer hours than Germans? Discussion Paper FS 1 -2-212 Wissenschaftsentrum Berlin fur Sozialforschung 2002, 2002.
- [154] Don Schierling, Geralee Hodne, and Michael Spangle. Approaching value-centered education through the eyes of an electronic generation: strategies for distance learning. In *Proceedings of the Annual Meeting of the National Communication Association*, New Orleans, LA, Nov 21-24 2002.
- [155] M. R. Schiller. E-cheating: Electronic plagiarism. *Journal of the American Dietetic Association*, 105:1058–1061, 2005.
- [156] C. Schlichting and J. Mason. Certification training and the academy. *Journal of Computing Sciences in Colleges*, 20:157–167, 2004.
- [157] Deborah A. Schreiber and Zane L. Berge. *Distance Training: How Innovative Organizations Are Using Technology To Maximize Learning and Meet Business Objectives*. Jossey-Bass Business and Management Series. Jossey-Bass Publishers, 1998.
- [158] W. Seetahal. Planning your career in information technology.
- [159] Heather Shea-Schultz and John Fogarty. *Online Learning Today*. Berrett-Koehler Publishers, San Francisco, California, 2002.
- [160] C. B. Shearer. Reliability, validity and utility of a multiple intelligences assessment for career planning. 1997.
- [161] C. Branton Shearer. *The MIDAS A Professional Manual*. MI Research & Consulting, 1316 South Lincoln Street, Kent Ohio 44240, 1996. The research and preparations of this manual was supported in part by an Innovation grant from the U.S. Department of

Education's National Institute on Disability and Rehabilitation Research grant No. H133C20085.

- [162] C. Branton Shearer. *Stepping Stones: A Teacher's Workbook*, 1999.
- [163] C. Branton Shearer. *The MIDAS Handbook of Multiple Intelligences in the Classroom*. Columbus, OH, 2005.
- [164] L Sherry. Issues in distance learning. *International Journal of Educational Telecommunications*, 1:337–365, 1996.
- [165] David Sigurnjak. Emotional intelligence and distance learning. EDF6608, Summer 2001.
- [166] Daniel S. Soper. The free statistics calculators website. Online Software. <http://www.danielsoper.com/statcalc/>.
- [167] Lee Sproull and Sara Kiesler. Computer, networks and work. In Michael B. Morgan, editor, *Readings in Human-Computer Interaction: Toward the Year 2000*, pages 755–761. Morgan and Kaufmann Publishers, 2 edition, 1995.
- [168] Joette Stefl-Mabry. Professional staff development: Lessons learned from current usability studies. *Journal of Information Technology Impact*, 1(2):81–104, 1999.
- [169] James F. Stenerson. Systems analysis and design for a successful distance education program implementation. *Online Journal of Distance Learning Administration*, 1(2):1–10, Summer 1998.
- [170] A. Sterngold. Confronting plagiarism: How conventional teaching invites cyber-cheating. *Change*, 36:166, 2004.

- [171] D. Straub, M. Keil, and W. Brenner. Testing the technology acceptance model across cultures: A three country study. *Information and Management*, 33(1):1–11, 1997.
- [172] William Sundstrom. The overworked American or the overestimated work-week? trend and bias in recent estimates of weekly work hours in the United States. Dept. of Economics Santa Clara University Santa Clara, CA 95053 wsundstrom@mailers.scu.edu, November 1999.
- [173] James C. Taylor. Fifth generation distance education. In *20th ICDE WORLD CONFERENCE ON OPEN LEARNING AND DISTNANCE EDUCATION The Future of Learning-Learning for the Future: Shaping the Transition*, April 2001. keynote address in the plenary session on wednesday, 04 April 2001.
- [174] Murray Thompson. An evaluation of the implementation of the dimensions of learning program in an Australian independent boys school. *International Education Journal*, 1(1):45–60, 1999.
- [175] Margarita Todorova and Valentina Petrova. Learning objects. In *International Conference on Computer Systems and Technologies*, 2003.
- [176] C. A. Tomlinson. *How to differentiate instruction in mixed-ability classrooms*. Association for Supervision and Curriculum Development Alexandria, Va, 2001.
- [177] Carol Ann Tomlinson. *Differentiated Classroom: Responding to the Needs of All Learners*. Assn for Supervision & Curriculum, April 1999.
- [178] K. Tyler-Smith. Early attrition among first time e-learners: A review of factors that contribute to drop-out, withdrawal and non-completion rates of adult learners undertaking e-learning programmes. *Journal of Online Learning and Teaching*, 2:73?85, 2006.

- [179] Jean Underwood and Attila Szabo. Academic offences and e-learning: individual propensities in cheating. *British Journal of Educational Technology*, 34(4):467–477, 2003.
- [180] Viswanath Venkatesh and Fred D. Davis. A theoretical extension of the technology acceptance model: Four longitudinal field studies. *Management Science*, 46(2):186–204, 2000.
- [181] Viswanath Venkatesh and Michael G. Morris. Why don't men ever stop to ask for directions? gender, social influence, and their role in technology acceptance and usage behavior. *MIS Q.*, 24(1):115–139, 2000.
- [182] John Verzani. *Using R for Introductory Statistics*. Chapman & Hall/CRC, 2005.
- [183] Richard Vigilante. Online computer scoring of constructed-response questions. *Journal of Information Technology Impact*, 1(2):57–62, 1999.
- [184] Richard S. Vosko. *Creating Environments for Effective Adult Learning*, chapter 3: Where We Learn Shapes Our Learning, pages 23–32. Number 50 in *New Directions For Adult And Continuing Education*. Jossey-bass Inc. Publishers, San Francisco, 1991.
- [185] Alvin Y. Wang and Michael H. Newlin. Predictors of web-student performance: The role of self-efficacy and reasons for taking an online class. *Computers in Human Behavior*, 2002.
- [186] Deryn M. Watson. Pedagogy before technology: Re-thinking the relationship between ICT and teaching. *Education and Information Technologies*, 6(4):251–266, Dec 2001. Publisher: Springer Science+Business Media B.V., Formerly Kluwer Academic Publishers B.V.

- [187] J. Weinstein and C. Dobkin. Plagiarism in US higher education: Estimating internet plagiarism rates and testing a means of deterrence. *Paper prepared under graduate student grant, Center for Studies in Higher Education, University of California, Berkeley, CA., 2002.*
- [188] Basil Whiting. The skills gap 2001: Manufacturers confront persistent skills shortages in an uncertain economy. Technical report, National Association of Manufacturers, 2001.
- [189] David A. Wiley II. *Learning Object Design and Sequencing Theory*. PhD thesis, Brigham Young University, June 2000. Department of Instructional Psychology and Technology.
- [190] Graham Williams. *rattle: A graphical user interface for data mining in R using GTK*, 2009. R package version 2.4.0.
- [191] J. Wirt, S. Choy, P. Rooney, S. Provasnik, A. Sen, and R. Tobin. *The Condition of Education 2004 (NCES 2004-077)*. U.S. Government Printing Office, U.S. Department of Education, National Center for Education Statistics. Washington, DC, 2004.
- [192] Anita E. Woolfolk. *Educational Psychology*. Prentice Hall, Englewood Cliffs, NJ, 4th edition, 1990.
- [193] Daniel S. Yates, David S. Moore, and Daren S. Starnes. *The Practice of Statistics*. W. H. Freeman and Company, New York, NY, 3 edition, 2008.
- [194] Chia-ping Yu. Toward an understanding of MIS survey research methodology: Current practices, trends, and implications for future research. *Academy of Information and Management Sciences Journal*, 6:39, Jan 2003.

- [195] A.J.K. Yuen and W.W.K Ma. Knowledge sharing and teacher acceptance of web-based learning system. In C. McBeath, Atkinson, D. Jonas-Dwyer, and R. Phillips, editors, *Beyond the comfort zone: Proceedings of the 21st ASCILITE Conference*, pages 975–983, 5-8 December 2004.
- [196] Allan H. K. Yuen and Will W.K. Ma. Gender differences in teacher computer acceptance. *Journal of Technology and Teacher education*, 10(3):365–382, 2002.
- [197] Alain F. Zuur, Elena N. Ieno, and Graham M. Smith. *Analysing Ecological Data*. Statistics for Biology and Health. Springer, New York, NY, 2007.

APPENDICES

APPENDIX A

Compiled Timeline

This information is taken directly from Issues and Controversies <http://www.2facts.com>, a 2002 Facts On File News Service.

Date	Event
1840	English educator Isaac Pitman begins teaching shorthand by mail correspondence to individuals seeking to learn secretarial skills
1874	Correspondence courses are introduced in the United States of America at Illinois Wesleyan University in Bloomington. The university offers both graduate and undergraduate degrees through its home-study program
1882	William Rainey Harper, often considered the father of distance education in the U.S., develops a correspondence program in Chautauqua, N.Y. Later, when Harper becomes the first president of the University of Chicago in 1891, he continues to expand distance learning in the United States of America

Date	Event
1992	Congress alters the Higher Education Act of 1965 to limit the amount of education a school can offer at a distance while still receiving federal financial aid. The changes, known informally as the "50% rule" and the "12-hour rule," are intended to crack down on fraudulent correspondence schools.
1998	Congress passes two initiatives under the Higher Education Amendments to encourage the exploration of distance learning via the Internet. Funding for those initiatives—the Distance Education Demonstration Program and the Learning Anytime Anywhere Partnerships (LAAP) Program—has continued to increase.
1999	Jones International University becomes the first accredited, fully on-line university. The decision to grant accreditation, or quality assurance, to a university that exists entirely on-line is met by criticism from many educators.

Date	Event
2000	In December, the Congressional Web-Based Education Commission, a panel established to assess educational technology and on-line learning, issues a report stating that the rules and regulations governing distance education are out of date and need to be reformed. In December, Congress approves the Education Department's \$30 million LAAP funding request for the 2001 fiscal year. LAAP had been funded at \$24 million in fiscal 2000 and at only \$10 million in fiscal 1999.

APPENDIX B

Bloom's Taxonomy

Instructional Methods for the EDNET Distance Learning Teacher, p44 <http://www.bbriefings.com/pdf/1417/lane.pdf>

Bloom's Taxonomy in a Traditional Classroom	Bloom's Taxonomy in a Distance Learning Classroom
1. Knowledge: Define the physics term force	1. Call on several students at different sites to come up with definitions of force. Discuss and come up with a suitable definition
2. Comprehension: Show how force is calculated	2. Have group discussions for five minutes. Give each group a sample force problem to solve and have each group demonstrate it.
3:Application: Set up a lever arm with a ruler and blocks of wood and demonstrate what force is	4. Make a Powerpoint slide presentation on mathematics of force and efficiency of a block and tackle or friction on an inclined plane.
4. Analysis: Explain why a pulley wheel multiplies force but sacrifices distance	5. Appoint each site and site facilitator to

Bloom's Taxonomy in a Traditional Classroom

Bloom's Taxonomy in a Distance Learning Classroom

5. Synthesis: Demonstrate how an inclined plane is like a screw.

6. Evaluation: Compare the efficiency of an inclined plane to lift an object compared to a block and tackle assembly.

APPENDIX C

elearning Tools

The following compilation is a list of course management software with respect to distance learning. Information was gathered from the following websites;

- <http://www.edutools.info/course/productinfo/index.jsp>
- <http://www.edutech.ch/lms/ev2.php>,
- http://www.unesco.org/webworld/portal_freesoft/Software/Courseware_Tools/
- http://directory.google.com/Top/Reference/Education/Instructional_Technology/Higher_Education/Course_Website_Software/

These tools have been classified by cost as either 1) commercially available and/or licensed, 2) open source implying freely available complete with source code, and 3) free not open source and possibly constrained to not for profit institutions.

Tool	Cost	Website
.LRN	O	http://dotlrn.org
ANGEL 5.6	C	http://www.cyberlearninglabs.com
ANGEL 6.0	C	http://www.cyberlearninglabs.com
ANGEL 6.1	C	http://www.cyberlearninglabs.com
ANGEL 6.2	C	http://www.cyberlearninglabs.com
Anlon 4.1	C	http://www.superioredge.com/

Tool	Cost	Website
ARIADNE project	C	http://www.ariadne-eu.org/
ATutor 1.4	O	http://www.atutor.ca
ATutor 1.4.2	O	http://www.atutor.ca
Avilar WebMentor 4.0	C	http://home.avilar.com/
Bazaar 7	O	http://klaatu.pc.athabascau.ca/cgi-bin/b7/main.pl?rid=1
BlackBoard 5.5	C	http://www.blackboard.com/
BlackBoard 6	C	http://www.blackboard.com/
Blackboard 6.2 Enterprise	C	http://www.blackboard.com/
Blackboard Academic Suite	C	http://www.blackboard.com/
Bodington	O	http://bodington.org/bodington/opensite/
BSCW 4.0.6 (Basic Support for Cooperative Work)	Free	http://bscw.gmd.de/
CentraOne 6.0	C	http://www.centra.com/products/centraone.asp
CHEF	O	http://chefproject.org/portal
Claroline 1.2.0	O	http://www.claroline.net/
Claroline 1.4	O	http://www.claroline.net/

Tool	Cost	Website
Class Campus	C	http://www.classcampus.com/home/asp/home.asp
Class Leader	C	http://www.classleader.com/
ClassWeb 2.0	O	http://classweb.ucla.edu/
Clix	C	http://www.im-c.de/
Colloquia 1.3.2	Free	http://www.colloquia.net
CoMentor	Free	http://comentor.hud.ac.uk/
COSE 2.051	O	http://www.staffs.ac.uk/COSE/
Coursemanager	C	http://www.coursemanager.com/cm/index.html
CourseWork	O	http://getcoursework.stanford.edu/
CyberProf	C	http://www.howhy.com/home/
Desire2Learn 7.2	C	http://www.desire2learn.com/
Desire2Learn 7.3	C	http://www.desire2learn.com/
eCollege AU+	C	http://www.ecollege.com
Educator	C	http://www.ucompass.com
EduSystem	C	http://www.mtsystem.hu/edusystem/en/
eLecture	O	http://physik.uni-graz.at/~cbl/electure/

Tool	Cost	Website
Eledge 1.2	O	http://eledge.sourceforge.net/
Eledge 3.1	O	http://eledge.sourceforge.net/
ETUDES	Free	http://www.foothillglobalaccess.org/etudes
eWebUniversity	C	http://www.ewebuniversity.com/education/products
FirstClass 8.0	C	http://www.centernity.com/
Fle3	C	http://fle3.uiah.fi/
Fronter	C	http://fronter.info/
Generation21 Enterprise	C	http://www.gen21.com/enterprise.htm
Globalteach	C	http://www.globalteach.com/
Groove Workspace 2.5	C	http://www.groove.net
HTMLeZ	C	http://learn.aero.und.edu/
IBT Server	C	http://www.time4you.de/
ILIAS	O	http://www.ilias.uni-koeln.de/ios/index-e.html
Interact	O	http://cce-interact.sourceforge.net/
Internet Course Assistant 2.0	Free	http://www.nicenet.org/
IntraKal	C	http://www.anlon.com/

Tool	Cost	Website
IntraLearn SME 3.1.2	C	http://www.intralearn.com/
IZIO	C	http://www.izio.com
Janison Toolbox 5.81	C	http://www.janison.com.au/
Janison Toolbox 6.2	C	http://www.janison.com.au/
Jenzabar Internet Campus Solution 1.03	C	http://www.jenzabar.net
Jones e-education V2004	O	http://www.jonesknowledge.com
KEWL	O	http://kewl.uwc.ac.za/
KnowEdge e-learning Suite	Free for non- profit	http://www.knowledge.net
Knowledge Forum 3	C	http://www.knowledgeforum.com/
Learnwise	C	http://www.learnwise.com/
LogiCampus	O	http://www.logicampus.com/
LON-CAPA 1.1	O	http://www.lon-capa.org/
LON-CAPA 1.2	O	http://www.lon-capa.org/

Tool	Cost	Website
Lotus LearningSpace	C	http://www.lotus.com/home.nsf/welcome/learnspace
Manhattan Virtual Classroom	O	http://manhattan.sourceforge.net/
Meritscholar	C	http://www.meritscholar.com
Merlin	C	http://www.hull.ac.uk/elearning/merlin/
MimerDesk 1.5.3.1	O	http://www.mimerdesk.org/
MimerDesk 2.0.1	O	http://www.mimerdesk.org/
Moodle 1.1	O	http://moodle.org
Moodle 1.4	O	http://moodle.org
Nautikus	C	http://www.odysseylearn.com/
Netaca	C	http://www.netaca.com
OLAT	O	http://www.olat-zentrum.unizh.ch/
Online Instructor Suite	C	http://www.onlinecoursetools.com/products.asp
Open Knowledge Initiative	O	http://www.okiproject.org/
OpenUSS	O	http://openuss.sourceforge.net/openuss/
Pythos	C	http://confluentforms.com
Qualilearning/Luvit 3.5	C	http://www.qualilearning.com/

Tool	Cost	Website
Sakai	C	http://sakaiproject.org/
Synapse	C	http://www.lance-tech.com
Teknical Virtual Campus	C	http://www.teknical.com/default.htm
TeleTop	C	http://www.teletop.nl
TextWeaver	O	http://www.textweaver.org
The Dialogue Project	C	http://dialogueproject.com
The Learning Manager 3.2	C	http://thelearningmanager.com/
The Learning Manager Enterprise Edition	C	http://thelearningmanager.com/
The Learning Sphere	C	http://thelearningsphere.com/
TopClass	C	http://www.wbtsystems.com
Unicon Academus	C	http://www.unicon.net/products/course.html
Virtual-U 2.5	C	http://www.vlei.com/
WebCT 3.8 Campus Edition	C	http://www.webct.com/
WebCT 4.0 Campus Edition	C	http://www.webct.com/
WebCT 4.1 Campus Edition	C	http://www.webct.com/
WebCT Vista 2.1	C	http://www.webct.com/

Tool	Cost	Website
WebCT Vista 3.0	C	http://www.webct.com/
Webstudy	C	http://www.webstudy.com/
WebTeach	C	http://www.webteach.com.au/
Whiteboard 1.0.2	O	http://whiteboard.sourceforge.net/
Wizlearn Academic 7	C	http://www.wizlearn.com
XplanaCourse	C	http://www.xplana.com/products/products_xc.php

APPENDIX D

Factors from the Literature

Table 4.1: TAM Factors

Author	Year	Perceived Ease of Use	Useability	Behavioral Intent to Use	Attitude	Subjective Norm	Self Efficacy	Intrinsic Motivation	Extrinsic Motivation	Skills & Experience	Feedback	Time & Time on Task	Learning Styles	Gender	Social	Culture	Anxiety	Satisfaction	Environment	Intent to Use/Acceptance	Theory of Reasoned Actions	Performance	Usage	Quality of Use	Age	Level of Education
Al-Gahani, Said S. and King, Malcolm	1999	*	*	*	*	*	*											*								
Bandura, A.	1982	*	*	*	*	*	*																			
Brosnan, M. J.	1999	*	*	*	*	*	*																			
Brown, Irwin T. J.	2002	*	*	*	*	*	*							*				*							*	
Davis, F. and Bagozzi, R. and Warshaw, P.	1989	*	*	*	*	*	*																			*
Davis, F. D.	1993	*	*	*	*	*	*																			
Fenech, Tino and Charles, Dennis and Merriees, Bill	1998	*	*	*	*	*	*																*			
Fishbein, M. and Ajzen, I.	1980				*	*	*																			
Hofstede, G.	1980																									
Huang, Echo		*	*	*	*	*	*			*	*	*	*									*	*	*	*	*
Hubona, Geoffrey		*	*	*	*	*	*			*	*	*	*									*	*	*	*	*
Hwang, Yujong and Yi, Mun Y.	2002	*	*	*	*	*	*		*														*	*	*	*
Johnson, R. A. and Hignite, Michael A.		*	*	*	*	*	*																		*	*
Lee, Jae-Shin and Cho, Hichang and Gay, Geri and Davidson, Barry and Ingraffea, Anthony	2003	*	*	*	*	*	*										*	*	*		*				*	*
Legris, Paul and Ingham, John and Colletrette, Pierre	2003	*	*	*	*	*	*								*											
Malhotra, Yogesh and Galletta, Dennis F.	1999	*	*	*	*	*	*		*																	
Marakas, George M. and Yi, Mun Y. and Johnson, Richard D.	1998	*	*	*	*	*	*																			
Martins, Luis L. and Kelleermanns, Franz Willl	2004	*	*	*	*	*	*																			
McFarland, Daniel J. and Cleary-Cannon, Kristina N.	2001	*	*	*	*	*	*						*													
Miller, Marc D. and Rainer, R. Kelly Jr. and Ken, Corley J.	2003	*	*	*	*	*	*					*														

Table 4.2: TAM Factors (continued)

Author	Year	Perceived Ease of Use	Useability	Behavioral Intent to Use	Attitude	Subjective Norm	Self Efficacy	Intrinsic Motivation	Extrinsic Motivation	* Skills & Experience	Feedback	Time & Time on Task	Learning Styles	Gender	Social	* Culture	Anxiety	Satisfaction	Environment	Intent to Use/Acceptance	* Theory of Reasoned Actions	Performance	Useage	Quality of Use	Age	Level of Education
Nink, Kristina	2003	*	*	*	*																					
Pajo, Karl	2000	*	*	*	*																					
Pan, Cheng-Chang and Sivo, Stephen and Brophy, James	2003	*	*	*	*	*	*																*	*		
Pan, Cheng-Chang Sam and Sivo, Stephen and Ellison, James Brophy and Phillips, William	2003	*	*	*	*	*	*																			
Salancik, G. R. and Pfeffer, J.	1978																									
Straub, D. and Keil, M. and Brenner, W.	1997																									
Tselios, Nikolaos K. and Avouris, Kikolaos M. and Dimitracopoulou, Angelique and Daskalaki, Sophia	2001	*	*																					*		
Venkatesh, Viswanath and Davis, Fred D.	2000	*	*	*	*	*	*		*																	
Venkatesh, Viswanath and Morris, Michael G.	2000	*	*	*	*	*	*																			
Yuen, A.J.K. and Ma, W.W.K.	2004	*	*											*						*	*					
Yuen, Allan H. K. and Ma, W.W.K.	2002	*	*																							

Table 4.3: Education Factors

Author	Year	Attitude	Gender	Subjective Norm	Time	Participation	Feedback	Self Efficacy	Learning Style	Multiple Intelligences	Intrinsic	Self Esteem	Multicultural Ethnic	Social Communication	Skills & Experience	Environment	Tech Barriers	Learning Outcomes	TAM PU & PEU	Performance	Achievement	Acceptance	Satisfaction	Online Culture	Age	Level of Education
Albalooshi, Fawzi and Alkhalifa,	2002		*																		*					
Eshaa M.																										
Arbaugh, J. B., Duray, Rebecca	1982		*				*	*																		
Bandura, A.	1998																									
Becker, D'Arcy and Dwyer, Meg	1998		*																							
Blum, Kimberly Dawn	1999								*	*																
Bork, Alfred	2001																									
Cadieux, Cynthia P.	2002							*													*					
Carchiolo, Vincenza and Longheu,	2002						*	*																		
Alessandro and Michele, Malgeri	2002			*																						
Chan, Bobbie	2002																									
Chase, Mackie and Macfadyen,													*											*		
Leah and Kenneth, Reeder and																										
Roché, Jorg	2002																									
Collins, Catherine, et al	1999			*				*													*	*				
Daley, Barbara J. and Watkins,					*														*	*						
Karen and Williams, Sandra Wall			*			*													*	*						
and Courtenay, Bradley and Mike,																										
Davis	2001																									
Gardner, Howard	2000								*																	
Hara, Noriko and Kling, Rob	2003			*																						
Hong, Kian-Sam and Ridzuan,			*																			*	*			
Abang Ahmad and Kuek, Ming-	2003		*																			*	*			
Koon																										
Hong, Kian-Sam, Lai Kwok-Wing,	2003		*				*	*														*	*			
Holton, Derek	2002							*																		
Inzary, Robert	2002							*																		
Johnson, Genevieve Marie	2005		*						*																	
Kerr, Marcel; Rynearson,												*														
Kimberly, Kerr Marcus	2003		*																							

Table 4.4: Education Factors (continued)

Author	Year	Attitude	Gender	Subjective Norm	Time	Participation	Feedback	Self Efficacy	Learning Style	Multiple Intelligences	Intrinsic	Self Esteem	Multicultural Ethnic	Social Communication	Skills & Experience	Environment	Tech Barriers	Learning Outcomes	TAM PU & PEU	Performance	Achievement	Acceptance	Satisfaction	Online Culture	Age	Level of Education
Krejins, Karel and Kirschner, Paul A. and Jochems, Wim	2003																			*						
Lane, Carla	2000									*																
Lapadat, Judith C.	2002	*																								
Leonard, A. C. and M., Motha W.	2001						*	*																		
Leuthold, Jane H.	1998								*																	
Linden, Julie	1998																									
Luca, Joe and McMahon, Mark	2001						*				*										*					
Mathew, Kathryn I. and Varagoor, Gita	2001								*												*					
Morse, Ken	2003																				*					
Njagi, Kageni and Smith, Ron and Isbell, Clift	2003	*					*	*																*		
O'Neil, Harold F.	2003		*				*																			*
Papp, Raymond	2001								*																	
Peters, Linda	2001		*																						*	*
Richardson, Jennifer C., Swan, Karen	2003						*																	*	*	*
Sigurnjak, David	2001								*											*						
Stell-Mabry, Joette	1999									*																

APPENDIX E

Generations of Distance Learning

From the plenary session of the 2001 conference of DL given by professor James C. Taylor Fifth Generation of Distance Learning http://www.fernuni-hagen.de/ICDE/D-2001/final/keynote_speeches/wednesday/taylor_keynote.pdf. “TABLE 1: Models of Distance Education: A Conceptual Framework”

Models of Distance Education and Associated Delivery Technologies	Time	Place	Pace	Highly Refined Materials	Advanced Interactive Delivery	Institutional Variable Costs Approaching Zero
FIRST GENERATION-The Correspondence Model						
• Print	Y	Y	Y	Y	N	N
SECOND GENERATION-The Multi-Media Model						
• Print	Y	Y	Y	Y	N	N
• Audiotape	Y	Y	Y	Y	N	N
• Videotape	Y	Y	Y	Y	N	N

Models of Distance Education and Associated Delivery Technologies	Time	Place	Pace	Highly Refined Materials	Advanced Interactive Delivery	Institutional Variable Costs Approaching Zero
• Computer-based learning (e.g. CML/CAL/IMM)	Y	Y	Y	Y	Y	N
• Interactive video (disk and tape)	Y	Y	Y	Y	Y	N
THIRD GENERATION-The Tele-learning Model						
• Audioteleconferencing	N	N	N	N	Y	N
• Videoconferencing	N	N	N	N	Y	N
• Audiographic Communication	N	N	N	Y	Y	N
• Broadcast TV/Radio and Audioteleconferencing	N	N	N	Y	Y	N

Models of Distance Education and Associated Delivery Technologies	Time	Place	Pace	Highly Refined Materials	Advanced Interactive Delivery	Institutional Variable Costs Approaching Zero
---	------	-------	------	--------------------------	-------------------------------	---

FOURTH GENERATION-The Flexible Learning Model

• Interactive multimedia (IMM) online	Y	Y	Y	Y	Y	Y
---------------------------------------	---	---	---	---	---	---

• Internet-based access to WWW resources	Y	Y	Y	Y	Y	Y
--	---	---	---	---	---	---

• Computer mediated communication	Y	Y	Y	Y	Y	N
-----------------------------------	---	---	---	---	---	---

FIFTH GENERATION-The Intelligent Flexible Learning Model

• Interactive multimedia (IMM) online	Y	Y	Y	Y	Y	Y
---------------------------------------	---	---	---	---	---	---

• Internet based access to WWW resources	Y	Y	Y	Y	Y	Y
--	---	---	---	---	---	---

Models of Distance Education and Associated Delivery Technologies	Time	Place	Pace	Highly Refined Materials	Advanced Interactive Delivery	Institutional Variable Costs Approaching Zero
<ul style="list-style-type: none"> • Computer mediated communication, using automated response systems 	Y	Y	Y	Y	Y	Y
<ul style="list-style-type: none"> • Campus portal access to institutional processes and resources 	Y	Y	Y	Y	Y	Y

APPENDIX F

Learning Concepts and Domains

Tables are compiled from information provided by TIP <http://tip.psychology.org/concepts.html>.

Table 6.1: Learning Domains

DOMAIN
Aviation
Computers
Concepts
Decision Making
Engineering
Language
Management
Mathematics
Medicine
Military
Perception
Problem Solving
Procedures
Reading
Reasoning
Sales
Sensory-Motor
Troubleshooting

Table 6.3: Learning Concepts

CONCEPT
Anxiety
Arousal
Attention
Attitudes
Cognitive/Learning Styles
Creativity
Feedback/Reinforcement
Imagery
Learning Strategy
Mastery
Memory
Mental Models
Metacognition
Motivation
Productions
Schema
Sequence of Instruction
Taxonomies

APPENDIX G

Learning Theories

Additional learning theories; TIP <http://tip.psychology.org/concepts.html>

THEORY	PROPONENT
ACT	J. Anderson
Adult Learning Theory	P. Cross
Algo-Heuristic Theory	L. Landa
Andragogy	M. Knowles
Anchored Instruction	J. Bransford & the CTGV
Aptitude-Treatment Interaction	L. Cronbach & R. Snow
Attribution Theory	B. Weiner
Cognitive Dissonance Theory	L. Festinger
Cognitive Flexibility Theory	R. Spiro
Cognitive Load Theory	J. Sweller
Component Display Theory	M. D. Merrill
Conditions of Learning	R. Gagne

THEORY	PROPONENT
Connectionism	E. Thorndike
Constructivist Theory	J. Bruner
Contiguity Theory	E. Guthrie
Conversation Theory	G. Pask
Criterion Referenced Instruction	R. Mager
Double Loop Learning	C. Argyris
Drive Reduction Theory	C. Hull
Dual Coding Theory	A. Paivio
Elaboration Theory	C. Reigeluth
Experiential Learning	C. Rogers
Functional Context Theory	T. Sticht
Genetic Epistemology	J. Piaget
Gestalt Theory	M. Wertheimer
GOMS	Card, Moran, & Newell
GPS	A. Newell & H. Simon

THEORY	PROPONENT
Information Pickup Theory	J. J. Gibson
Information Processing Theory	G. A. Miller
Lateral Thinking	E. DeBono
Levels of Processing	Craik & Lockhart
Mathematical Learning Theory	R.C. Atkinson
Mathematical Problem Solving	A. Schoenfeld
Minimalism	J. M. Carroll
Model Centered Instruction and Design Layering	A. Gibbons
Modes of Learning	D. Rumelhart & D. Norman
Multiple Intelligences	H. Gardner
Operant Conditioning	B.F. Skinner
Originality	I. Maltzman
Phenomenonography	F. Marton & N. Entwistle
Repair Theory	K. VanLehn
Script Theory	R. Schank

THEORY	PROPONENT
Sign Theory	E. Tolman
Situated Learning	J. Lave
Soar	A. Newell et al.
Social Development	L. Vygotsky
Social Learning Theory	A. Bandura
Stimulus Sampling Theory	W. Estes
Structural Learning Theory	J. Scandura
Structure of Intellect	J. Guilford
Subsumption Theory	D. Ausubel
Symbol Systems	G. Salomon
Triarchic Theory	R. Sternberg

APPENDIX H

MIDAS Profile

Students each received their own personalized MIDAS profile.

Figure 8.1: Sample MIDAS Profile Page 1

MULTIPLE INTELLIGENCES DEVELOPMENTAL ASSESSMENT SCALES
MIDAS Version 3.2 Processed 03-23-2009
for

Sex: M Grade: 16 Birth Date:
ID number: 0000000000 Code: 00.09

The following Profile represents areas of strength and limitation as reported by you at this time. This is preliminary information to be confirmed by way of further discussion and exploration.

Scales

Musical *****
Kinesthetic *****
Logical-Mathematical *****
Spatial *****
Linguistic *****
Interpersonal *****
Intrapersonal *****
Naturalist *****

The following Profile represents your intellectual style. These scales indicate if you tend to be more inventive, accurate or social in your problem solving abilities.

Scales

Leadership *****
General Logic *****
Innovative *****

Completed items: 97%

Figure 8.2: MIDAS Profile Page 2

MIDAS Profile for ID: 0000000000 Page 2

The MIDAS subscales are listed below hierarchically from the highest at the top to the lowest at the bottom of the list. These scales are qualitative indicators of specific areas of strength and preference.

Specific Skill	Category
School Math	Logical-Mathematical
Logic Games	Logical-Mathematical
Everyday Math	Logical-Mathematical
Calculations	Intrapersonal
Spatial Problem-Solving	Intrapersonal
Expressive	Linguistic
Art Design	Spatial
Science	Naturalist
Spatial Awareness	Spatial
Effectiveness	Intrapersonal
Personal Knowledge	Intrapersonal
Everyday Problem-Solving	Logical-Mathematical
Working with Objects	Spatial
Communication	Leadership
Composer	Musical
Management	Leadership
Rhetorical	Linguistic
Written/Reading	Linguistic
Plant Care	Naturalist
Persuasion	Interpersonal
Dexterity	Kinesthetic
Working with People	Interpersonal
Social	Leadership
Appreciation	Musical
Animal Care	Naturalist
Sensitivity	Interpersonal
Athletic	Kinesthetic
Vocal	Musical
Instrument	Musical

Figure 8.3: MIDAS Profile Page 3

MIDAS Profile for ID: 0000000000 Page 3

The following are percentage scores based on the total number of completed items for the main scales and subscales. Approximate category ranks are included to aid interpretation. Please refer to the current manual for interpretative information.

Clusters	Score	Score
Musical	19 Very Low	
Appreciation		21 Low
Instrument		0 Very Low
Vocal		0 Very Low
Composer		50 Moderate
Kinesthetic	19 Very Low	
Athletic		8 Very Low
Dexterity		29 Low
Logical-Mathematical	76 High	
School Math		92 Very High
Logic Games		81 Very High
Everyday Math		80 Very High
Everyday Problem-Solving		58 Moderate
Spatial	67 High	
Spatial Awareness		70 High
Art Design		70 High
Working with Objects		56 Moderate
Linguistic	55 Moderate	
Expressive		71 High
Rhetorical		47 Moderate
Written/Reading		44 Moderate
Interpersonal	29 Low	
Persuasion		42 Moderate
Sensitivity		17 Very Low
Working with People		25 Low
Intrapersonal	67 High	
Personal Knowledge		61 High
Calculations		80 Very High
Spatial Problem-Solving		80 Very High
Effectiveness		65 High
Naturalist	41 Moderate	
Science		70 High
Animal Care		21 Low
Plant Care		44 Moderate
Leadership	46 Moderate	
Communication		55 Moderate
Management		50 Moderate
Social		25 Low

APPENDIX I

TAM Survey

This survey represents a compilation of TAM related questions modified to fit this research.

Figure 9.1: TAM Survey Page 1

STUDENT NAME:	STUDENT ID NUMBER:
TEACHER:	CLASS:
SCHOOL:	PERIOD:

Complete all of the above

TECHNOLOGY ACCEPTANCE SURVEY

Cleveland State University Department of Information Systems

Introduction

Thank you for agreeing to take part in this study. Your participation in this survey will give valuable insight into how teenagers view taking classes over the Internet. Please read each question carefully and thoughtfully before responding. Be sure to complete all portions of the survey. Mark your answers by filling in the appropriate bubble. If you must erase, then be sure to erase your previous answer completely. When you have finished please turn the survey over and wait for further instructions from your teacher.

NOTE: You may only take this survey if you have submitted a permission slip to your teacher. All responses made to this survey are confidential. If you have any questions about this survey or research project, consult your release forms or contact Mr. DeGennaro by phone at (216)371-7101 or via email at a_degennaro@chuh.org.

Perceived Ease of Use

	Strongly Disagree	Disagree	Moderately Disagree	Neither Agree nor Disagree	Moderately Agree	Agree	Strongly Agree
1. Moodle is easy to use.	<input type="radio"/>	<input type="radio"/>	<input type="radio"/>	<input type="radio"/>	<input type="radio"/>	<input type="radio"/>	<input type="radio"/>
2. Moodle is easy to learn.	<input type="radio"/>	<input type="radio"/>	<input type="radio"/>	<input type="radio"/>	<input type="radio"/>	<input type="radio"/>	<input type="radio"/>
3. Moodle is user friendly.	<input type="radio"/>	<input type="radio"/>	<input type="radio"/>	<input type="radio"/>	<input type="radio"/>	<input type="radio"/>	<input type="radio"/>
4. Moodle is easy to master.	<input type="radio"/>	<input type="radio"/>	<input type="radio"/>	<input type="radio"/>	<input type="radio"/>	<input type="radio"/>	<input type="radio"/>
5. Learning to use Moodle is easy for me.	<input type="radio"/>	<input type="radio"/>	<input type="radio"/>	<input type="radio"/>	<input type="radio"/>	<input type="radio"/>	<input type="radio"/>
6. I believe interacting with Moodle is a clear and understandable process.	<input type="radio"/>	<input type="radio"/>	<input type="radio"/>	<input type="radio"/>	<input type="radio"/>	<input type="radio"/>	<input type="radio"/>
7. I find Moodle flexible to interact with.	<input type="radio"/>	<input type="radio"/>	<input type="radio"/>	<input type="radio"/>	<input type="radio"/>	<input type="radio"/>	<input type="radio"/>
8. It is easy for me to become skillful at using Moodle.	<input type="radio"/>	<input type="radio"/>	<input type="radio"/>	<input type="radio"/>	<input type="radio"/>	<input type="radio"/>	<input type="radio"/>
9. It is easy to navigate the Moodle website.	<input type="radio"/>	<input type="radio"/>	<input type="radio"/>	<input type="radio"/>	<input type="radio"/>	<input type="radio"/>	<input type="radio"/>
10. I could quickly find the information I need.	<input type="radio"/>	<input type="radio"/>	<input type="radio"/>	<input type="radio"/>	<input type="radio"/>	<input type="radio"/>	<input type="radio"/>
11. I would find it easy to get Moodle to do what I want it to do.	<input type="radio"/>	<input type="radio"/>	<input type="radio"/>	<input type="radio"/>	<input type="radio"/>	<input type="radio"/>	<input type="radio"/>

Behavioral Intention to Use

	Strongly Disagree	Disagree	Moderately Disagree	Neither Agree nor Disagree	Moderately Agree	Agree	Strongly Agree
12. I would use Moodle for communicating with others.	<input type="radio"/>	<input type="radio"/>	<input type="radio"/>	<input type="radio"/>	<input type="radio"/>	<input type="radio"/>	<input type="radio"/>
13. I intend to encourage my teacher to teach class with Moodle.	<input type="radio"/>	<input type="radio"/>	<input type="radio"/>	<input type="radio"/>	<input type="radio"/>	<input type="radio"/>	<input type="radio"/>
14. I intend to take classes that use Moodle.	<input type="radio"/>	<input type="radio"/>	<input type="radio"/>	<input type="radio"/>	<input type="radio"/>	<input type="radio"/>	<input type="radio"/>
15. I intend to use Moodle for learning my lessons.	<input type="radio"/>	<input type="radio"/>	<input type="radio"/>	<input type="radio"/>	<input type="radio"/>	<input type="radio"/>	<input type="radio"/>

Figure 9.2: TAM Survey Page 2

Perceived Usefulness

	Strongly Disagree	Disagree	Moderately Disagree	Neither Agree nor Disagree	Moderately Agree	Agree	Strongly Agree
16. I find Moodle an overall useful tool.	<input type="radio"/>	<input type="radio"/>	<input type="radio"/>	<input type="radio"/>	<input type="radio"/>	<input type="radio"/>	<input type="radio"/>
17. The information on the Moodle site interests me.	<input type="radio"/>	<input type="radio"/>	<input type="radio"/>	<input type="radio"/>	<input type="radio"/>	<input type="radio"/>	<input type="radio"/>
18. I find that Moodle adds value to a class.	<input type="radio"/>	<input type="radio"/>	<input type="radio"/>	<input type="radio"/>	<input type="radio"/>	<input type="radio"/>	<input type="radio"/>
19. Using Moodle improves my learning.	<input type="radio"/>	<input type="radio"/>	<input type="radio"/>	<input type="radio"/>	<input type="radio"/>	<input type="radio"/>	<input type="radio"/>
20. Moodle would be useful in my classes.	<input type="radio"/>	<input type="radio"/>	<input type="radio"/>	<input type="radio"/>	<input type="radio"/>	<input type="radio"/>	<input type="radio"/>
21. Using Moodle for teaching increases student learning.	<input type="radio"/>	<input type="radio"/>	<input type="radio"/>	<input type="radio"/>	<input type="radio"/>	<input type="radio"/>	<input type="radio"/>
22. Using Moodle enhances my learning effectiveness.	<input type="radio"/>	<input type="radio"/>	<input type="radio"/>	<input type="radio"/>	<input type="radio"/>	<input type="radio"/>	<input type="radio"/>
23. Using Moodle makes it easier to learn.	<input type="radio"/>	<input type="radio"/>	<input type="radio"/>	<input type="radio"/>	<input type="radio"/>	<input type="radio"/>	<input type="radio"/>
24. Using Moodle enables one to earn better grades.	<input type="radio"/>	<input type="radio"/>	<input type="radio"/>	<input type="radio"/>	<input type="radio"/>	<input type="radio"/>	<input type="radio"/>
25. Using Moodle in a course enhances student performance.	<input type="radio"/>	<input type="radio"/>	<input type="radio"/>	<input type="radio"/>	<input type="radio"/>	<input type="radio"/>	<input type="radio"/>
26. Using Moodle in a course makes it easier for students to do assignments.	<input type="radio"/>	<input type="radio"/>	<input type="radio"/>	<input type="radio"/>	<input type="radio"/>	<input type="radio"/>	<input type="radio"/>
27. Using Moodle improves participation.	<input type="radio"/>	<input type="radio"/>	<input type="radio"/>	<input type="radio"/>	<input type="radio"/>	<input type="radio"/>	<input type="radio"/>
28. Using Moodle enables me to accomplish tasks more quickly.	<input type="radio"/>	<input type="radio"/>	<input type="radio"/>	<input type="radio"/>	<input type="radio"/>	<input type="radio"/>	<input type="radio"/>
29. Using Moodle keeps me organized.	<input type="radio"/>	<input type="radio"/>	<input type="radio"/>	<input type="radio"/>	<input type="radio"/>	<input type="radio"/>	<input type="radio"/>
30. Moodle is useful for my school work.	<input type="radio"/>	<input type="radio"/>	<input type="radio"/>	<input type="radio"/>	<input type="radio"/>	<input type="radio"/>	<input type="radio"/>
31. I would use Moodle in a class that offered it.	<input type="radio"/>	<input type="radio"/>	<input type="radio"/>	<input type="radio"/>	<input type="radio"/>	<input type="radio"/>	<input type="radio"/>
32. I would use Moodle over the web.	<input type="radio"/>	<input type="radio"/>	<input type="radio"/>	<input type="radio"/>	<input type="radio"/>	<input type="radio"/>	<input type="radio"/>
33. Interacting with Moodle is something that I would do.	<input type="radio"/>	<input type="radio"/>	<input type="radio"/>	<input type="radio"/>	<input type="radio"/>	<input type="radio"/>	<input type="radio"/>
34. Using Moodle makes a course more interesting.	<input type="radio"/>	<input type="radio"/>	<input type="radio"/>	<input type="radio"/>	<input type="radio"/>	<input type="radio"/>	<input type="radio"/>

Attitude Toward Using

	Strongly Disagree	Disagree	Moderately Disagree	Neither Agree nor Disagree	Moderately Agree	Agree	Strongly Agree
35. I would have fun interacting with Moodle.	<input type="radio"/>	<input type="radio"/>	<input type="radio"/>	<input type="radio"/>	<input type="radio"/>	<input type="radio"/>	<input type="radio"/>
36. Using Moodle would interest me.	<input type="radio"/>	<input type="radio"/>	<input type="radio"/>	<input type="radio"/>	<input type="radio"/>	<input type="radio"/>	<input type="radio"/>
37. All things considered, my using Moodle in my education is a <u>WISE</u> idea.	<input type="radio"/>	<input type="radio"/>	<input type="radio"/>	<input type="radio"/>	<input type="radio"/>	<input type="radio"/>	<input type="radio"/>
38. All things considered, my using Moodle in my education is a <u>POSITIVE</u> idea.	<input type="radio"/>	<input type="radio"/>	<input type="radio"/>	<input type="radio"/>	<input type="radio"/>	<input type="radio"/>	<input type="radio"/>
39. All things considered, my using Moodle in my education is a <u>BENEFICIAL</u> idea.	<input type="radio"/>	<input type="radio"/>	<input type="radio"/>	<input type="radio"/>	<input type="radio"/>	<input type="radio"/>	<input type="radio"/>
40. All things considered, my using Moodle in my education is a <u>GOOD</u> idea.	<input type="radio"/>	<input type="radio"/>	<input type="radio"/>	<input type="radio"/>	<input type="radio"/>	<input type="radio"/>	<input type="radio"/>

Figure 9.3: TAM Survey Page 3

Uses of Computer Technology

	Strongly Disagree	Disagree	Moderately Disagree	Neither Agree nor Disagree	Moderately Agree	Agree	Strongly Agree
41. I use a computer daily.	<input type="radio"/>	<input type="radio"/>	<input type="radio"/>	<input type="radio"/>	<input type="radio"/>	<input type="radio"/>	<input type="radio"/>
42. I can find things I am looking for on the Internet easily.	<input type="radio"/>	<input type="radio"/>	<input type="radio"/>	<input type="radio"/>	<input type="radio"/>	<input type="radio"/>	<input type="radio"/>
43. I am an expert in the use of the Internet.	<input type="radio"/>	<input type="radio"/>	<input type="radio"/>	<input type="radio"/>	<input type="radio"/>	<input type="radio"/>	<input type="radio"/>
44. I am an expert in the use of a computer.	<input type="radio"/>	<input type="radio"/>	<input type="radio"/>	<input type="radio"/>	<input type="radio"/>	<input type="radio"/>	<input type="radio"/>

	Never	Rarely	Sometimes	Frequently	Daily
45. I use a computer to do my homework.	<input type="radio"/>	<input type="radio"/>	<input type="radio"/>	<input type="radio"/>	<input type="radio"/>

	0	1-2	3-4	5-6	7 or More
46. Number of email accounts that you use.	<input type="radio"/>	<input type="radio"/>	<input type="radio"/>	<input type="radio"/>	<input type="radio"/>
47. Number of online classes you have taken.	<input type="radio"/>	<input type="radio"/>	<input type="radio"/>	<input type="radio"/>	<input type="radio"/>
48. Number of classes you have taken that required the use of the Internet to complete assignments.	<input type="radio"/>	<input type="radio"/>	<input type="radio"/>	<input type="radio"/>	<input type="radio"/>

49. I have accounts on
(CHECK ALL THAT APPLY)

- a. MySpace
- b. FaceBook
- c. SecondLife
- d. Flickr
- e. MyYearbook
- f. Student.com
- g. Twitter
- h. YouTube
- i. MUDs or MUSHes
- j. Other

50. Every day, I read or visit
(CHECK ALL THAT APPLY)

- a. blogs
- b. wikis
- c. RSS feeds
- d. email
- e. online news reports
- f. online comics
- g. IMs
- h. chat rooms
- i. movie or TV websites
- j. music or music video websites
- k. online game websites

APPENDIX J

Gender and Ethnicity

The coplots below partition the data by gender and ethnicity. The x-axis is the sum of the MIDAS intelligences and ranges from 0 to 800. The scatterplots do not show any linearity for any of the subsets. Coplots of individual intelligences and their subscales all have similar distributions to those depicted here and are omitted.

Figure 10.1: Coplots: MIDAS PEUmean/PUmean by Gender by Ethnicity

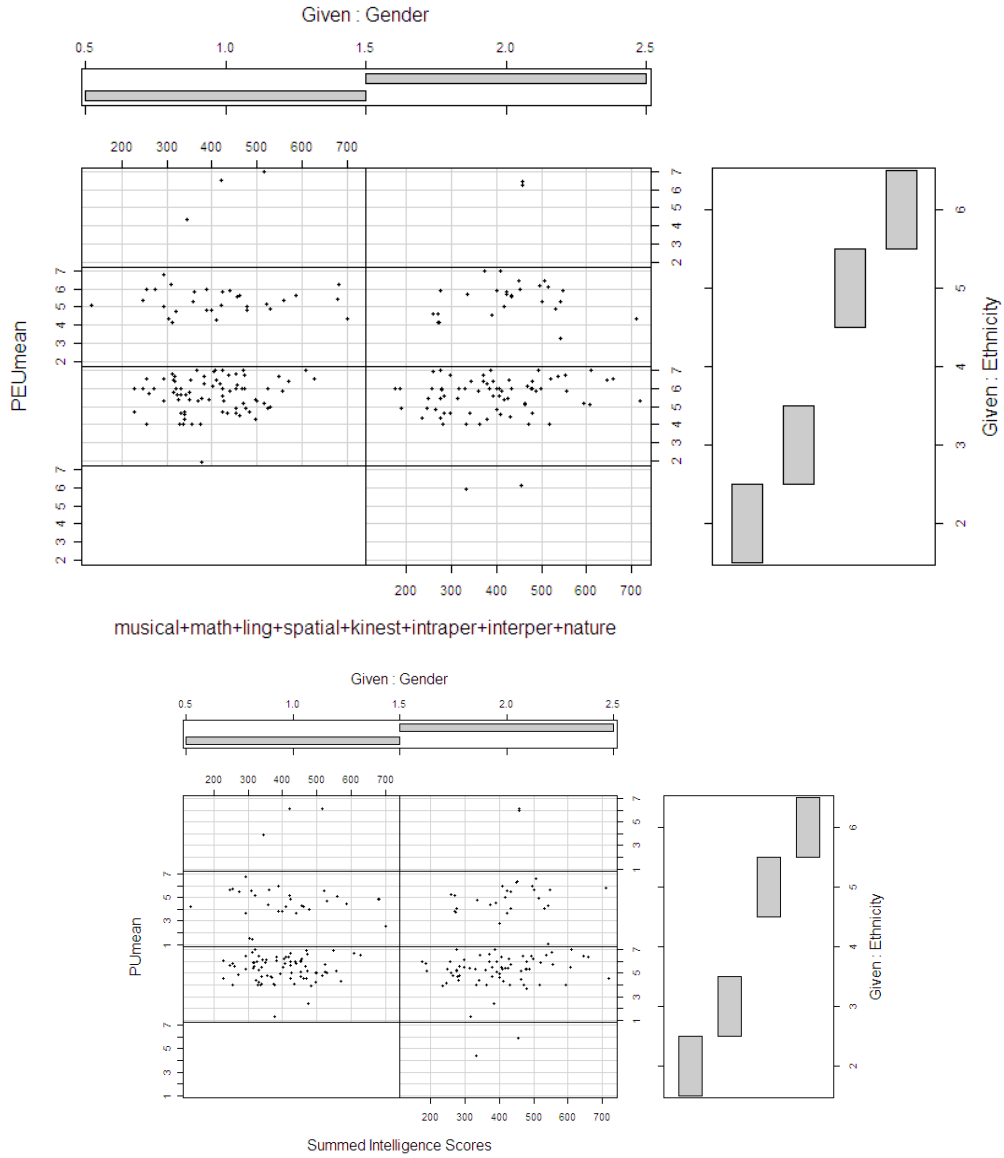

Gender 1=male, 2=female. Ethnicity a numerical value 1 through 6. The composite of multiple intelligences forms the x-axis. The results are not different for individual multiple intelligences.

APPENDIX K

TAMFACTORS & MIDAS Subscales

These plots have 3 distinct features. The diagonal provides a histogram and density plot of the specific intelligence subscale. Below the diagonal is a scatterplot between and LOESS line fitted to the data. Above the diagonal is the correlation between factors.

Figure 11.1: TAM Correlated to MIDAS Musical Subscales

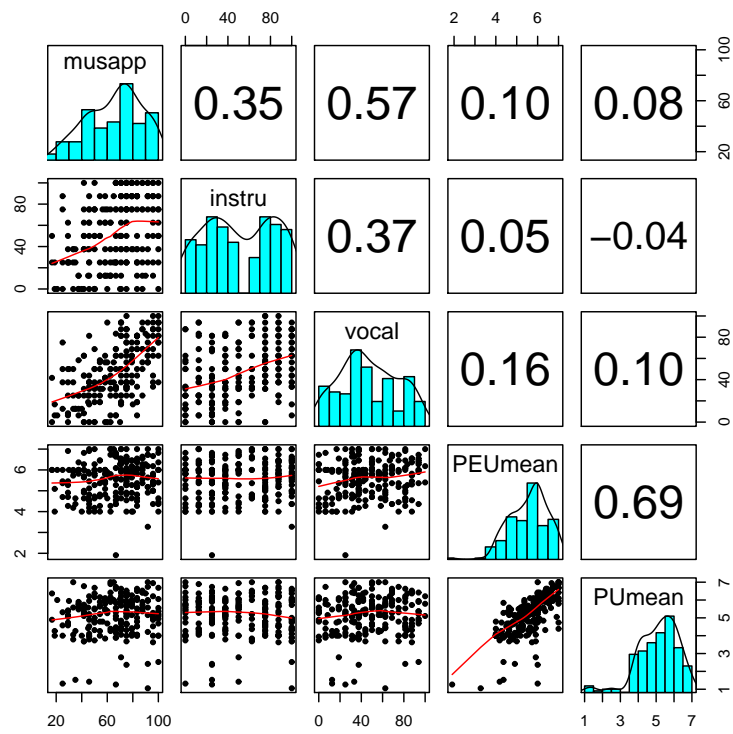

Figure 11.2: TAM Correlated to MIDAS Logic/Mathematical Subscales

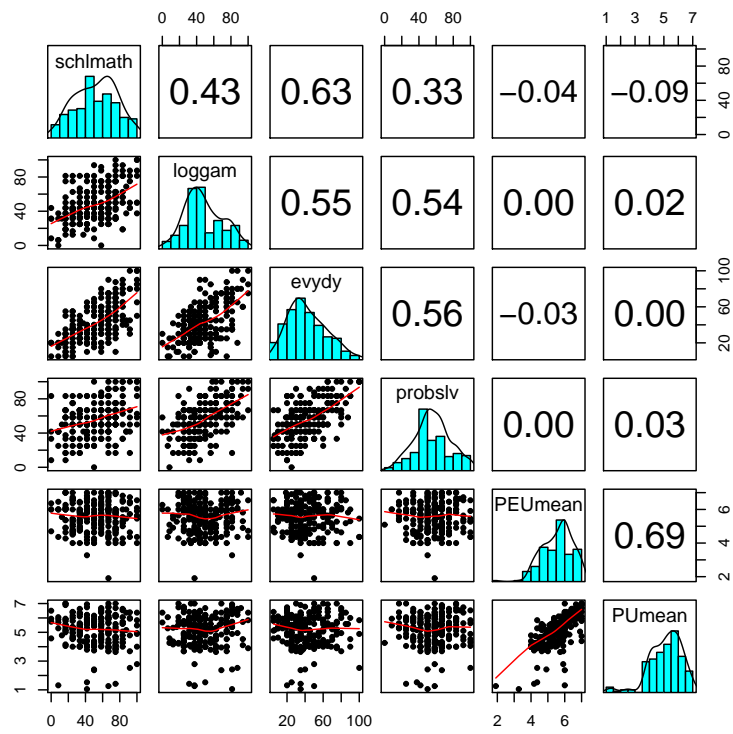

Figure 11.3: TAM Correlated to MIDAS Kinesthetic Subscales

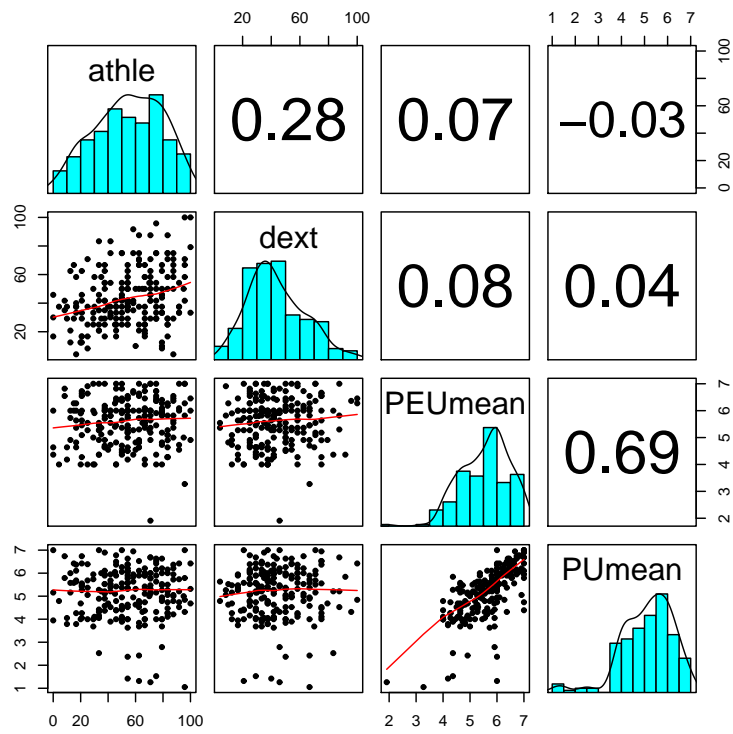

Figure 11.4: TAM Correlated to MIDAS Linguistic Subscales

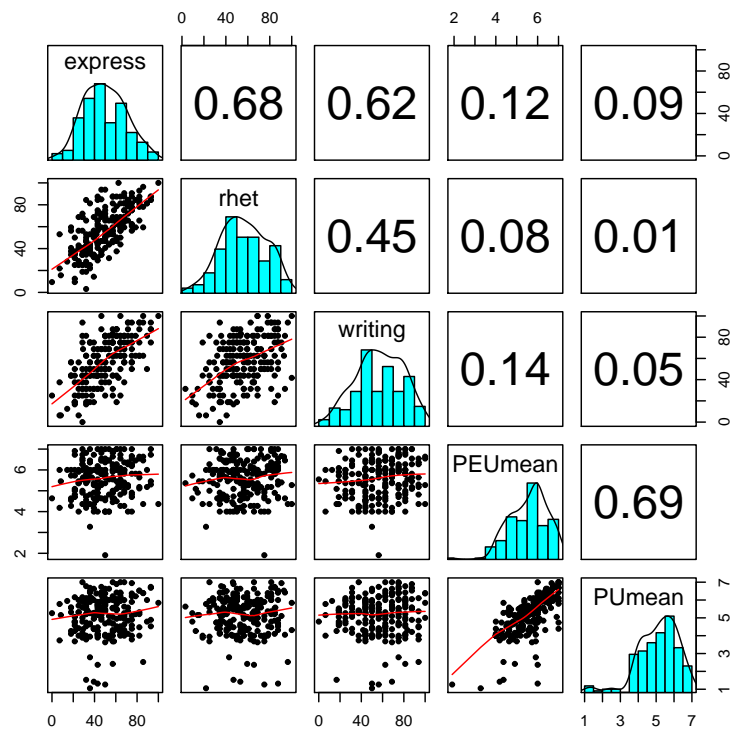

Figure 11.5: TAM Correlated to MIDAS Spatial Subscales

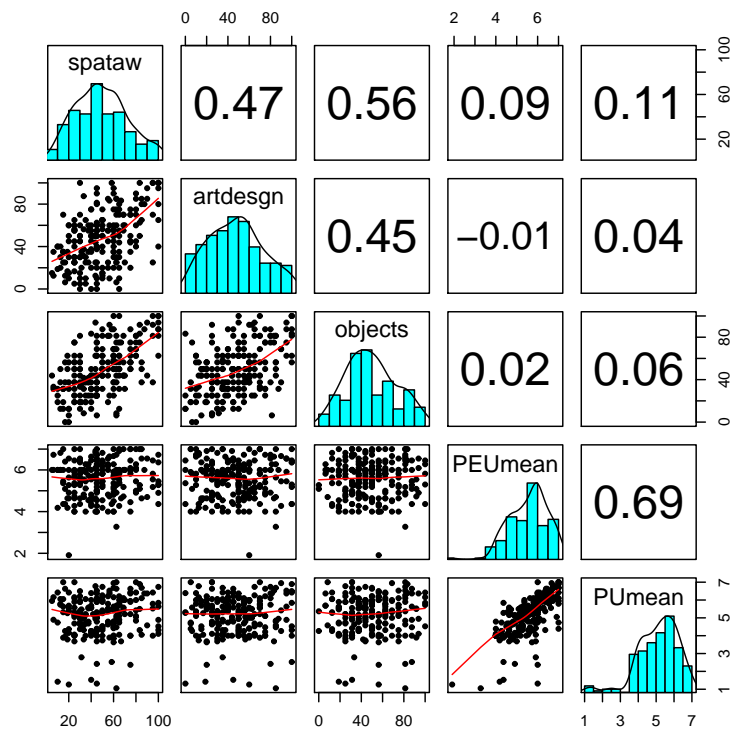

Figure 11.6: TAM Correlated to MIDAS Interpersonal Subscales

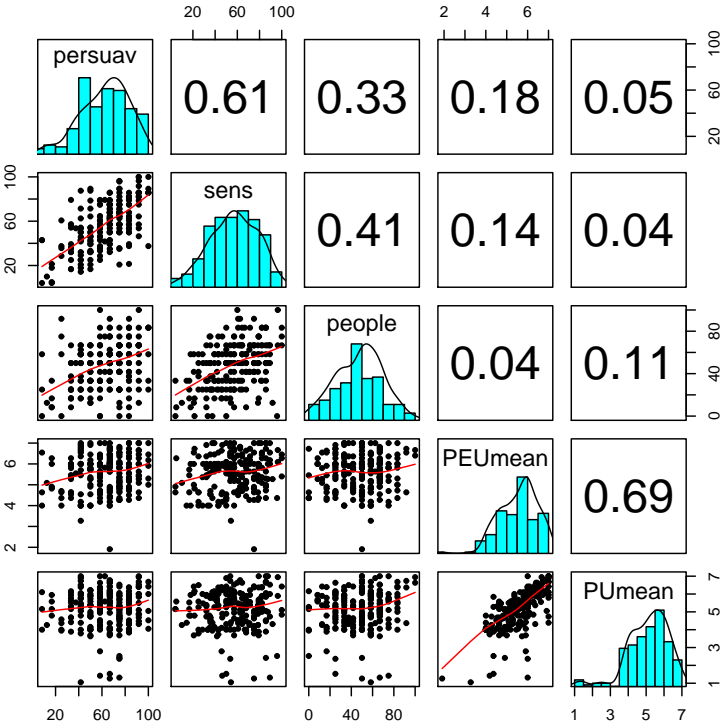

Figure 11.7: TAM Correlated to MIDAS Intrapersonal Subscales

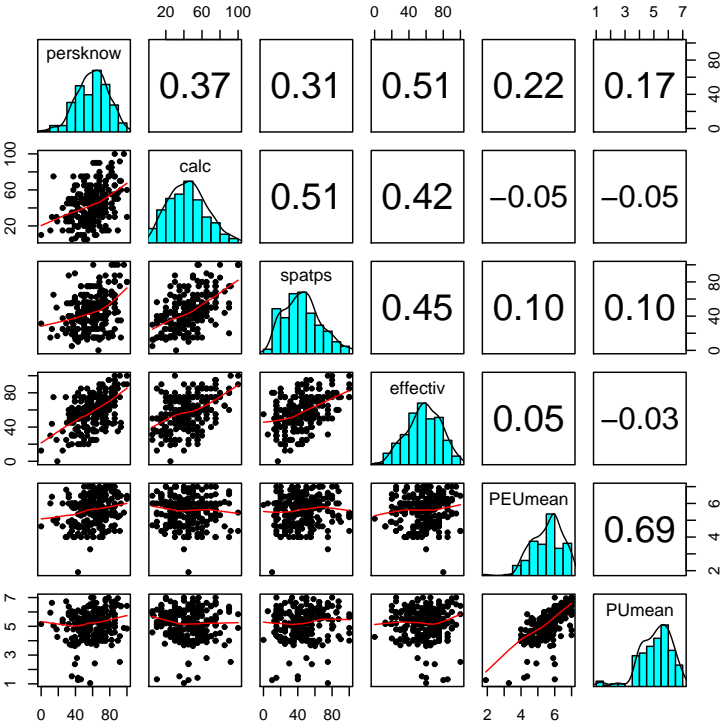

Figure 11.8: TAM Correlated to MIDAS Nature Subscales

