

ETD Archive

2014

Developing Improved Bridge Parapet Designs

Lauren A. Hedges
Cleveland State University

Follow this and additional works at: <https://engagedscholarship.csuohio.edu/etdarchive>



Part of the [Civil and Environmental Engineering Commons](#)

How does access to this work benefit you? Let us know!

Recommended Citation

Hedges, Lauren A., "Developing Improved Bridge Parapet Designs" (2014). *ETD Archive*. 821.
<https://engagedscholarship.csuohio.edu/etdarchive/821>

This Thesis is brought to you for free and open access by EngagedScholarship@CSU. It has been accepted for inclusion in ETD Archive by an authorized administrator of EngagedScholarship@CSU. For more information, please contact library.es@csuohio.edu.

DEVELOPING IMPROVED BRIDGE PARAPET DESIGNS

LAUREN A. HEDGES

Bachelor of Science in Civil Engineering
Cleveland State University
May 2013

submitted in partial fulfillment of requirements for the degree
MASTER OF SCIENCE IN CIVIL ENGINEERING
at the
CLEVELAND STATE UNIVERSITY
May 2014

We hereby approve this thesis for

Lauren Hedges

Candidate for the Master of Science in Civil Engineering degree for the

Department of Civil and Environmental Engineering

and the CLEVELAND STATE UNIVERSITY

College of Graduate Studies

Thesis Chairperson, Dr. Norbert Delatte

Department & Date

Thesis Committee Member, Dr. Lutful Khan

Department & Date

Thesis Committee Member Dr. Mehdi Jalalpour

Department & Date

Student's Date of Defense: April 30th, 2014

ACKNOWLEDGEMENTS

This study was sponsored by the Ohio Department of Transportation, and received support by Civil and Environmental Engineering Department, the Washkewicz College of Engineering, and the College of Graduate Studies at Cleveland State University.

Many individuals from ODOT assisted in the success of this study. The research team would like to acknowledge and thank the following individuals: Dale Crawl, Richard Walters, and Michael Kubek for providing technical information, and Jim Farrel, Marc Sakien, and Tom Beutler for coordinating and assisting with field work. I would also like to thank Fawaz K. Saraf, P.E., Rod Maas, Steve Reichenbach, Brandon Collett, P.E., Matthew Chynoweth, P.E., Michael Lee, Walter Peters, P.E., Dennis Heckman, Mike Ebright, and Kent Barnes for providing photographs and correspondence.

DEVELOPING IMPROVED BRIDGE PARAPET DESIGNS

LAUREN A. HEDGES

ABSTRACT

The Ohio Department of Transportation has identified that premature parapet cracking is a significant problem in Northeast Ohio. Background research related to concrete cracking and parapet cracking was conducted to determine possible causes of the premature cracking that ODOT has discovered. To further look at possible causes of this cracking, current ODOT bridge parapet practices were reviewed.

In addition to ODOT practices, ten other state DOTs were surveyed to identify the bridge parapet practices used. These practices include the parapet design characteristics, construction joint spacing and depth, and the class of concrete used for construction. Various differences among all of these characteristics were identified and discussed to determine an improved bridge parapet design.

Many of the districts located within ODOT were also surveyed and asked to identify premature bridge parapet cracking repair or replacement projects. Four of the districts were able to present twelve separate bridge parapet cracking projects. From these projects, it was determined that ODOT spends on average \$188,175 per bridge parapet replacement project, or \$283 per linear foot (\$86 per meter) of parapet.

Based on the state DOTs that confirmed parapet cracking was not a problem for their state, parapet improvements were determined. These improvements include decreasing the maximum construction joint spacing, and increasing the joint cut depth.

TABLE OF CONTENTS

ABSTRACT..... iv

LIST OF TABLES..... viii

LIST OF FIGURES ix

CHAPTERS

 I. INTRODUCTION.....1

 1.1 ODOT PROBLEM STATEMENT1

 1.2 STUDY OBJECTIVES2

 1.3 BENEFITS AND POTENTIAL APPLICATION OF RESEARCH RESULTS
.....2

 1.4 ORGANIZATION OF THIS REPORT3

 II. LITERATURE REVIEW.....4

 2.1 CAUSES OF PARAPET CRACKING4

 2.1.1 SHRINKAGE CRACKING4

 2.1.2 FLEXURAL STRESSES5

 2.1.3 CORROSION6

 2.1.4 CONSTRUCTION PRACTICES.....7

 2.2 IMPORTANCE OF PARAPET CRACKING8

 2.2.1 OBSERVATIONS FROM ODOT DISTRICTS9

 2.3 PUBLISHED RESEARCH STUDIES FROM OTHER STATE DOTs11

 2.3.1 PERFORMANCE OF MICHIGAN’S CONCRETE BARRIERS.....11

 2.3.2 CAUSES AND CURES FOR CRACKING OF CONCRETE BARRIERS 13

 2.3.3 WISCONSIN DEPARTMENT OF TRANSPORTATION14

 2.4 CORRELATION TO OTHER STUDIES.....16

 III. CURRENT OHIO DEPARTMENT OF TRANSPORTATION PRACTICES18

 3.1 DESIGN SPECIFICATIONS.....18

 3.2 CONSTRUCTION JOINTS.....19

 3.3 CONCRETE MIX.....20

 3.4 CONSTRUCTION PROCEDURES21

 IV. OTHER DEPARTMENT OF TRANSPORTATION PRACTICES.....23

 4.1 VIRGINIA DEPARTMENT OF TRANSPORTATION.....23

 4.1.1 CONSTRUCTION JOINTS24

 4.1.2 CONCRETE MIX25

4.2 MARYLAND DEPARTMENT OF TRANSPORTATION.....	25
4.2.1 CONSTRUCTION JOINTS	26
4.2.2 CONCRETE MIX	28
4.3 MICHIGAN DEPARTMENT OF TRANSPORTATION	28
4.3.1 CONSTRUCTION JOINTS	29
4.4 MISSOURI DEPARTMENT OF TRANSPORTATION.....	29
4.4.1 CONSTRUCTION JOINTS	30
4.4.2 CONCRETE MIX	31
4.5 MONTANA DEPARTMENT OF TRANSPORTATION	31
4.5.1 CONSTRUCTION JOINTS	32
4.5.2 CONCRETE MIX	33
4.6 OKLAHOMA DEPARTMENT OF TRANSPORTATION	33
4.6.1 CONSTRUCTION JOINTS	34
4.6.2 CONCRETE MIX	35
4.7 IDAHO DEPARTMENT OF TRANSPORTATION.....	35
4.7.1 CONSTRUCTION JOINTS	36
4.7.2 CONCRETE MIX	37
4.8 ALABAMA DEPARTMENT OF TRANSPORTATION.....	37
4.8.1 CONSTRUCTION JOINTS	38
4.9 CALIFORNIA DEPARTMENT OF TRANSPORTATION	39
4.10 MINNESOTA DEPARTMENT OF TRANSPORTATION	40
4.10.1 CONSTRUCTION JOINTS	41
4.10.2 CONCRETE MIX.....	42
V. REPAIR PROJECTS	43
5.1 ODOT DISTRICT 1	44
5.1.1 BRIDGE NUMBER VAN-30-2041	44
5.1.2 BRIDGE NUMBER ALL-75-1836	44
5.1.3 BRIDGE NUMBER ALL-696-0086.....	45
5.1.4 BRIDGE NUMBER ALL-65-1322	46
5.2 ODOT DISTRICT 3	47
5.2.1 PID 81374.....	47
5.3 ODOT DISTRICT 8	48
5.3.1 BRIDGE NUMBER GRE-675-0895.....	48
5.3.2 BRIDGE NUMBER HAM-74-1116L.....	49
5.3.3 BRIDGE NUMBER GRE-675-1034.....	50

5.3.4 BRIDGE NUMBER GRE-42-0789	51
5.3.5 BRIDGE NUMBER GRE-380-0671	52
5.4 ODOT DISTRICT 12	53
5.4.1 BRIDGE NUMBER CUY-71-0000	53
5.4.2 BRIDGE NUMBER CUY-17-0449	54
5.5 CALIFORNIA DOT	54
5.5.1 RANCHERIA CREEK BRIDGE	54
5.5.2 BIG CREEK BRIDGE	55
5.5.3 TAMARACK CREEK BRIDGE	55
VI. ANALYSIS	56
6.1 COMPARISON OF DOT PRACTICES	56
6.1.1 CONCRETE COVER	56
6.1.2 HORIZONTAL REBAR	57
6.1.3 VERTICAL SPACING	58
6.2 CONSTRUCTION JOINT COMPARISON	60
6.2.1 JOINT DEPTH	60
6.3 CONCRETE MIX COMPARISON	61
6.4 STATE DOT PARAPET PERFORMANCE	63
6.4.1 STATES WITH POOR PARAPET PERFORMANCE	64
6.4.2 STATES WITH ADEQUATE PARAPET PERFORMANCE	65
6.5 ODOT COST ANALYSIS	66
6.6 CALTRANS COST ANALYSIS	68
VII. CONCLUSIONS	70
7.1 DESIGN PRACTICE CONCLUSION	70
7.1.1 CONSTRUCTION JOINT SPACING	71
7.1.2 CONSTRUCTION JOINT CUT DEPTH	71
7.1.3 CEMENT CONTENT	72
VIII. BRIDGE PARAPET DESIGN RECOMMENDATIONS	73
8.1 MAXIMUM CONSTRUCTION JOINT SPACING	73
8.2 CONSTRUCTION JOINT DEPTH	73
8.3 OTHER RECOMMENDATIONS	74
8.4 FINAL IMPROVED BRIDGE PARAPET DESIGN RECOMMENDATIONS	75
8.5 EXPECTED BENEFITS OF RECOMMENDED IMPLEMENTATION	75
REFERENCES	77

LIST OF TABLES

Table	
Page	
I.	Current State DOT Parapet Practices.....59
II.	State DOT Joint Spacing.....61
III.	State DOT Concrete Mixes.....63
IV.	ODOT Bridge Parapet Repair Project Costs.....68
V.	Caltrans Bridge Parapet Repair Project Costs.....69

LIST OF FIGURES

Figure	Page
1. Finished Bridge Parapet.....	8
2. Vertical Parapet Cracking.....	10
3. I-95 Parapet Concrete Void.....	17
4. Ohio Department of Transportation Parapet Profile.....	19
5. GRFP Saw Cut Perimeter Profile.....	20
6. Virginia Department of Transportation Parapet Profile.....	24
7. Maryland Department of Transportation Parapet Profile.....	26
8. Maryland DOT Joint Cut Depth.....	27
9. Maryland DOT Saw Cut Length.....	27
10. Michigan Department of Transportation Parapet Profile.....	29
11. Missouri Department of Transportation Parapet Profile.....	30
12. MODOT Construction Joint.....	31
13. Montana Department of Transportation Parapet Profile.....	32
14. Oklahoma Department of Transportation Parapet Profile.....	34
15. Oklahoma Department of Transportation Control Joints.....	35
16. Idaho Department of Transportation Parapet Profile.....	36
17. IDT Dummy Joints.....	37
18. Alabama Department of Transportation Parapet Profile.....	38
19. ALDOT Construction Joints.....	39

20.	California Department of Transportation Parapet Profile.....	40
21.	Minnesota Department of Transportation Parapet Profile.....	41
22.	ODOT District Map.....	43
23.	Bridge Number ALL-75-1836 Cracking.....	45
24.	Bridge Number ALL-696-0086 Cracking.....	46
25.	Bridge Number ALL-65-1322 Cracking.....	47
26.	Bridge Number GRE-675-0895 Cracking.....	49
27.	Bridge Number HAM-74-1116L Cracking.....	50
28.	Bridge Number GRE-675-1034 Cracking.....	51
29.	Bridge Number GRE-42-0789.....	52
30.	Bridge Number GRE-380-0671 Cracking.....	53

CHAPTER 1

INTRODUCTION

The Ohio Department of Transportation (ODOT) has identified that premature bridge parapet cracking is a prominent problem in northeast Ohio. Parapets are concrete barriers that are placed on the external edges of a bridge. Various districts within ODOT have expressed concerns about bridge parapet cracking.

1.1 ODOT Problem Statement

Cracking can range from small hairline cracks to large cracks that expose rebar. Therefore, parapet cracking is not only an aesthetic concern, but it can also be a safety concern. Many of the districts in Ohio have had repair projects that were triggered by excessive parapet cracking. The bridge parapets involved in repair projects have varied in length, number of spans, and locations throughout Ohio. One thing that has had little to no variation is the design of the parapets.

Repairing parapets before the bridge deck needs to be repaired is very costly. It is economically better for ODOT to develop repair projects that include replacement of both the parapet and bridge deck all at once, rather than two separate projects.

1.2 Study Objectives

The main objective of this study is to develop an improved bridge parapet design that will reduce the amount of premature cracking, therefore saving ODOT money. To accomplish this, various characteristics of the parapet design, composition, and construction were examined.

The main characteristics that were evaluated include:

- How closely construction joints should be spaced.
- Depth the construction joints should be cut.
- The amount of rebar used in the parapet.
- Spacing of the horizontal rebar.
- The amount of concrete cover over horizontal rebar.
- The type of concrete used.

1.3 Benefits and Potential Application of Research Results

Through research and analysis of current ODOT bridge parapet standards and other DOT bridge parapet standards, potential improved designs can be developed. If implemented, the designs could address the problem of premature cracking of bridge

parapets seen throughout northeast Ohio. This will reduce the number of bridge parapet repair and replacement projects required, ultimately reducing costs to ODOT.

1.4 Organization of this Report

This report consists of eight chapters. The first chapter is the introduction, followed by a literature review in the second chapter. The third chapter, Current Ohio Department of Transportation Practices, discusses the ODOT's current practices for bridge parapet design and construction.

In the fourth and fifth chapters, ten other state DOTs were surveyed to identify their current bridge parapet design and construction practices. The fourth chapter consists of those state DOTs that have similar practices to those of ODOT. The fifth chapter consist of those state DOTs that have practices different than those of ODOT.

The sixth chapter, Repair Projects, provides information on bridge parapet repair and replacement projects that have occurred in four of the twelve ODOT districts, and some that have occurred in California.

In the seventh chapter, Analysis, differences between ODOT and other state DOTs' parapet designs and construction practices are discussed. The eighth and final chapter, Conclusions and Recommendations, discusses all of the previous analysis and suggests recommendations for ODOT to implement regarding bridge parapet design.

CHAPTER II

LITERATURE REVIEW

Information from published literature regarding bridge parapet cracking was gathered from various sources and reviewed. The gathered studies and reports provide information that parapet cracking is not only a problem in Ohio, but in many other areas as well.

2.1 Causes of Parapet Cracking

Cracking in concrete can occur for various reasons such as shrinkage cracking, flexural stresses, reinforcement corrosion, and construction practices.

2.1.1 Shrinkage Cracking

There are three different types of shrinkage cracking that can result, which are plastic, drying, and thermal. Plastic shrinkage will occur when the concrete is starting to harden. This concrete will lose moisture faster than normal, causing cracks to form. These plastic shrinkage cracks may occur as only small cracks, but have the potential to become deeper with time (Mindess, et. al, 2003).

Drying shrinkage will occur later in the hardening process, perhaps weeks, months or even years after placement. This concrete slowly loses its moisture. According to ACI Committee 224, 2007, “the amount of drying shrinkage is influenced mainly by the amount and type of aggregate and the cement paste content of the mixture (p.3).” If concrete contains a larger amount of cement per cubic yard of concrete, then it has a higher potential for drying shrinkage cracking (ACI 224.1R, 2007). Additionally, according to ACI Committee 224R, if the surface area to volume ratio is larger, there is also a greater chance that the concrete will crack (ACI 224R-01, 2001).

Thermal shrinkage occurs due to a significant temperature changes. When two separate sections of the structure lose heat at different rates, then thermal shrinkage is more likely to occur. These different rates of temperature change can cause the volume of the concrete to expand at different rates, and ultimately crack where the two sections of the structure meet (ACI 224.1R, 2007).

2.1.2 Flexural Stresses

Cracking can also be caused by flexural stresses. If a significant load is applied to the bridge, the parapets may form cracks due to high tensile stress. The weakening of a material by repeated loading is known as fatigue. After the structure has endured the loading and unloading cycle many times, the parapet concrete may form microcracks. Reinforced concrete is less susceptible to fatigue due to the extra resistance added by steel reinforcement, but after some time it too can begin to crack (Wight & MacGregor, 2012). There are long term effects of the loading and unloading of a structure with microcracks. According to ACI Committee 224R, “the increase in crack width due to

long term or repetitive loading can vary between 100 and 200 percent over several years,” (ACI 224R-01, 2001).

Vibrations of parapet concrete early following its placement can also lead to cracking. If the parapet is under vibration, pockets can form under the rebar and allow cracks to form. These pockets also provide ideal space for water to pool, which can cause corrosion to the rebar (Wight & MacGregor, 2012). If the parapet is properly restrained by the formwork, this can sometimes help to reduce the damage from the vibrations (ACI 224R-01, 2001).

2.1.3 Corrosion

The corrosion of steel reinforcement within concrete can also cause it to crack. If the reinforcement is exposed to moisture, oxygen and chlorides, then the steel begins to oxidize. “Corrosion of the steel produces iron oxides and hydroxides that have a volume much greater than the volume of the original metallic iron,” (p.4, ACI 224.1R-07, 2007). The best way to reduce the chance of corrosion, is to make sure the concrete cover over the reinforcement is thick enough, and to use concretes that have a low permeability.

Corrosion of the concrete can also affect the bond between the reinforcement and concrete. According to ACI Committee 224R, “over a period of time the adhesion bond between the steel and the concrete undergoes breakdown (p.5).” This breakdown can cause an increase in crack width and depth.

2.1.4 Construction Practices

Concrete cracking can also be attributed to improper construction practices. The main construction practices that effect concrete cracking are adding water to the concrete and not curing the concrete long enough. According to ACI Committee 224, “an increase in water content will also mean an increase in the temperature differential between the interior and exterior portions of the structure, resulting in increased thermal stresses and possible cracking,” (p.4, ACI 224.1R-07, 2007).

Before starting the curing process, the concrete structure should be properly finished once the formwork is removed. This is an important step in the construction process that can affect the risk of cracking. Plastic shrinkage should be taken into consideration at this time, however, ensuring that the concrete does not dry out. Additionally, extra water or cement paste should not be added to help finish the concrete, (ACI 224R-01, 2001). An example of a properly finished concrete parapet can be seen in Figure 1 below.



Figure 1: Finished Bridge Parapet (Photo Provided by Lauren Hedges)

Curing the concrete for an adequate amount of time is also important to reduce the possibility of cracking. “The early termination of curing will allow for increased shrinkage at a time when the concrete has low strength,” (p.6, ACI 224.1R, 2007). The drying of the concrete can also affect the strength of the concrete. A decrease in strength allows for an increase in cracking risk (ACI 224.1R, 2007). According to ACI Committee 224, “the best curing environment is to keep the concrete continuously wet during the curing period (p.6).” It is standard for most curing processes to last around seven days.

2.2 Importance of Parapet Cracking

When cracking in concrete occurs, it allows water and other contaminants to enter. Once inside, water has the ability to expand as it freezes in colder temperatures which can increase the size of the crack or even break concrete off the structure. Also, salts that

enter the concrete can cause reinforcement within the concrete to corrode. This corrosion can compromise the integrity of the structure (Mindess, et. al, 2003).

Since cracks can allow unwanted substances to enter the concrete, and create ideal conditions for corrosion, it is important to reduce parapet cracks. This is especially important in Northeast Ohio where parapet cracking is a significant problem.

2.2.1 Observations from ODOT Districts

District 12 in ODOT is not the only district to have experienced problems with parapet cracking. Additional information was collected from ODOT District 8, which is located in the Southwest portion of Ohio. According to Brandon Collett, P.E. and structures planning engineer for District 8, many bridge parapets located in their district also suffer from prominent vertical cracking (Brandon Collett, P.E., personal communication, October 21, 2013). An example of the vertical cracking seen in these districts can be seen in Figure 2.



Figure 2: Vertical Parapet Cracking (Photo Provided by Lauren Hedges)

Many of the older bridges with these cracks were seen upon were constructed through the use of slip forming. Slip forming is the construction of a parapet with the use of pulling or lifting a form while concrete is placed. The machine moves at a slow but

steady pace, placing concrete with a low slump into the shape of the parapet, over the set rebar. This practice is currently not allowed for use on parapets constructed in District 12 and a few other districts within ODOT, but new construction specifications will allow the use of slip forming in the coming year.

District 8 has also shown concern for their older bridges that received a joint cut that passes entirely through the parapet. A through joint allows for an air gap between segments of the parapet. The parapets that received this type of joint cut have also been subjected to severe cracking near the joints. The final observation from District 8 is that bridges with large spans see the most and worst type of cracking.

Although there is a lot of parapet cracking to be found within ODOT District 8, Brandon Collett, P.E. argues that vertical cracks are “just an eye sore” and not a maintenance issue. Adding that horizontal cracking, and cracking due to vandal protection fences (VPFs) are the causes of real problems for their district (Brandon Collett, P.E., personal communication, October 21, 2013).

2.3 Published Research Studies from Other State DOTs

A search of information regarding bridge parapet performance and cracking was conducted for other state DOTs. The search resulted in three separate studies, in which two were carried out by the Michigan DOT and one from the Wisconsin DOT.

2.3.1 Performance of Michigan’s Concrete Barriers

In 2007, the Michigan Department of Transportation conducted a study on bridge barrier design. In this study, they wanted to review three main areas:

- Types of bridge barrier design configurations.
- Field performance of bridge barrier design.
- Potential factors that may contribute to premature deterioration.

Michigan DOT conducted this study due to frequent premature cracking of parapets, and the need to replace them multiple times throughout the lifespan of a bridge (Staton & Knauff, 2007).

This report begins with the discussion of how bridge barriers have changed, starting as concrete posts with metal lattice between them in the 1960's, up until today with the use of Jersey type concrete barrier. This Jersey type barrier was adopted in 1977, but has seen changes throughout the years, such as the approved use of slip forming in 1982 (Staton & Knauff, 2007).

To assess the performance of the bridge barriers, inspections of bridges began in 1997. Core samples were collected from twenty-six different bridge sites. These bridge construction dates ranged from 1973 to 1990 (Staton & Knauff).

Additionally, parapets made using cast-in-place methods and slip forming were both inspected and analyzed, and aggregate type such as natural gravel, slag and crushed limestone was investigated. Then, the cores were tested in a laboratory and rated either poor, fair, or good. Of the twenty-six cores taken, ten were rated poor, ten were rated fair, and six were rated good (Staton & Knauff, 2007).

The cores and other loose concrete collected at the sites was then investigated through petrography. This showed that alkali-silica gel had formed on many of the pieces. Petrography also concluded that near the surface on many of the slip formed parapets, the

concrete was very porous, which easily allows for penetration of concrete by harmful materials (Staton & Knauff, 2007).

It was concluded that more parapets throughout Michigan should be examined and evaluated for replacement. Among the recommendations, some included (Staton & Knauff, 2007):

- No longer allow the use of low durability coarse aggregates for parapets.
- Slip forming should no longer be accepted for the construction of parapets.
- A minimum of seven day water cure.
- Epoxy coated reinforcement should be used.
- Overall concrete quality improvement should be investigated.

2.3.2 Causes and Cures for Cracking of Concrete Barriers

In 2004, the Michigan Department of Transportation conducted a study to identify the causes and cures for prematurely deteriorating parapets in Michigan. Possible causes that were examined included freezing and thawing, alkali-silica reactions, ettringite, and carbonation effects. Then experimental equipment was used to conduct more research on sixteen cores from eight different locations (Van Dam, et. al, 2004).

The parapets in Michigan were subjected to different types of cracking, such as “map cracking, vertical transverse cracking, horizontal cracking, delamination, pop-outs, scaling, and disintegration” (p.1, Van Dam, et. al, 2004). The cores were collected from parapets constructed from 1983 until 2001. Cores were taken from parapets constructed using both cast-in-place and slip forming construction methods.

Sixteen cores were taken from various sites along the highway. The cores were then polished, examined, and prepared for petrographic study. Some of the methods of examination included the stereo optical microscopy, x-ray analytical microscopy, petrographic optical microscopy, and scanning electron microscopy. Finally, the cores were tested for carbonation through the use of phenolphthalein spray. The cores would turn pink with a pH higher than 8.3; if the concrete didn't change color it was carbonated (Van Dam, et. al, 2004).

This study resulted in a few conclusions and recommendations (Van Dam, et. al, 2004):

- Consolidation problems were seen in the cores, which included many air voids.
- Air void system protecting against freezing and thawing was negatively affected by the use of the slip form method.
- Ettringite was found in many of the cores' air voids.
- A study should be initiated of the alkali-silica reactivity that was present.
- Siltstones that were observed in some of the concrete cores were susceptible to frost.
- One of the sites had significant corrosion, which resulted in high carbonation.

2.3.3 Wisconsin Department of Transportation

In 2008, the Wisconsin Department of Transportation conducted a study to determine the effects of a shrinkage reducing admixture called Eclipse. The goal of the admixture was to reduce the amount of shrinkage cracks that occur in the parapets during the curing process (Battaglia, et. al, 2008).

Originally, the study began with the use of the admixture in the concrete for bridge decks in 2000. The project later investigated the admixture for the use in bridge parapets in 2003. The admixture was to be used in two separate sets of bridge parapets, but due to complications was only used in one (Battaglia, et. al, 2008).

The concrete used for both the test parapet and control parapet was evaluated in a laboratory setting, where cylinders were tested for compressive strength and shrinkage. At three days, the compressive strength of the experimental cylinder, control cylinder one, and control cylinder two was 3,150 psi (21.7 MPa), 2,790 psi (19.2 MPa), and 2,720 psi (18.8 MPa), respectively (Battaglia, Whited, & Swank, 2008).

More cylinders were later tested at 7 days, 28 days, and 90 days. At the 90 day mark, the compressive strengths for the experimental cylinder, control cylinder number one, and control cylinder number two were 6,880 psi (47.4 MPa), 6,230 psi (43 MPa), and 6,290 psi (43.4 MPa), respectively (Battaglia, et. al, 2008).

To determine the amount of shrinkage, the change in length was measured for the three cylinders at 3, 7, 28, 56, and 90 days. At three days, the percentages of shrinkage for the experimental cylinder, control cylinder one and control cylinder two were 0.005 percent, 0.006 percent, and 0.007 percent, respectively (Battaglia, et. al, 2008). At the end of ninety days, the percentages of shrinkage were 0.021 percent, 0.024 percent and 0.024 percent for the experimental cylinder, control cylinder one, and control cylinder two, respectively (Battaglia, et. al, 2008).

The sites were visited twice to determine how the parapets in service were performing. The first site visit took place two months after construction. At that time, the experimental parapets showed three cracks in each parapet, while the control parapets

revealed up to nine in each parapet. When the second site visit took place, four years later, the experimental parapet had no new cracking, while the control parapets had up to seven new cracks per parapet (Battaglia, et. al, 2008).

The Wisconsin Department of Transportation concluded that the Eclipse admixture helped to reduce shrinkage cracking for both short and long term periods. Ultimately, however, the Wisconsin DOT decided that it should not be used, because of how the air content in the concrete was affected (Bittaglia, et. al, 2008).

2.4 Correlation to Other Studies

The Virginia Department of Transportation (VDOT) conducted a study that looked at various bridges on I-95 Express Lanes in Virginia. VDOT examined cracking that occurred on both the bridge decks and parapets. On the bridge decks, both map cracking and transverse cracks were seen. Most of the cracks observed on the bridge deck were thought to be mainly due to plastic, thermal and drying shrinkage (Saraf, 2013).

The parapets were also subject to vertical cracks as wide as 0.05 inches (1 mm). Two core samples were taken at the location of where the cracks can be seen. For both cores, concrete voids were present around the vertical rebar, as seen in Figure 3 below. Because the parapets were constructed using the slip forming method, it is thought that the voids may have occurred due to the low slump and poor vibration methods not allowing the concrete to flow around to the underside of the vertical rebar (Saraf, 2013).



Figure 3: I-95 Parapet Concrete Void (Photo Provided by Fawaz K. Saraf, P.E.)

CHAPTER III

CURRENT OHIO DEPARTMENT OF TRANSPORTATION PRACTICES

To improve ODOT's bridge parapet design, the current parapet specifications and characteristics should be examined. The specifications and characteristics will be evaluated for their effectiveness.

3.1 Design Specifications

The most current specification drawings can be found on ODOT's website, located within the Standard Bridge Drawings. As of July, 2013, ODOT specifies that bridge parapets must be 3' tall. Parapets must have a bottom width of 1'-6" (457 mm), and a top width of 8 ½" (216 mm).

There are a total of seven horizontal pieces of rebar. The horizontal piece of rebar located at the top of the parapet must be size #6 (19 mm), and the remaining six pieces should be #5 (16 mm) rebar, which is a total cross-sectional area of 1.99 in² (1,284 mm²) (ODOT, 2013).

Vertical rebar will run along the backside of the parapet and bend over the top piece of rebar. The vertical rebar should be placed every twelve inches along the length of the parapet. Two additional pieces of rebar will extend into the bridge deck for a minimum of 7 ½” (191 mm) of embedment. All vertical rebar should be #5 (16 mm) in size.

There should be at least 2 ½” (64 mm) of concrete cover on all edges of the parapet. The profile view of ODOT’s bridge parapet can be seen in Figure 4 (ODOT, 2013).

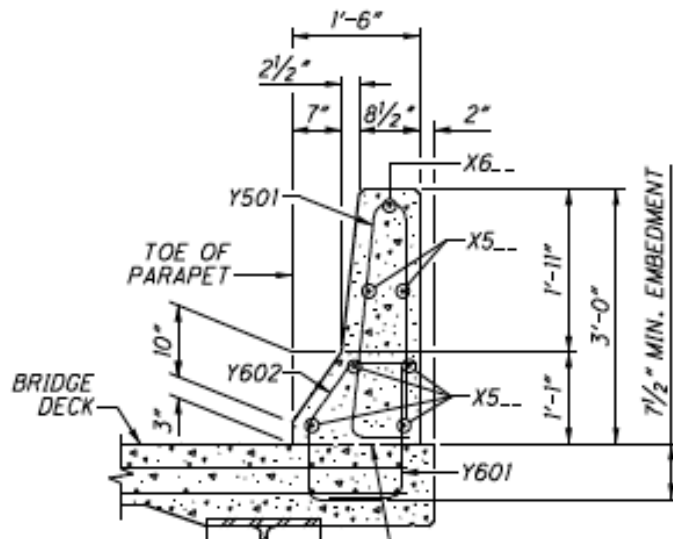

Figure 4: Ohio Department of Transportation Parapet Profile (ODOT, 2013)

3.2 Construction Joints

Construction joints will be placed above each pier. Additional joints will be spaced evenly throughout the remaining length of the parapet. The joint spacing cannot exceed 15’ (4.6 m) on center. Within the negative moment zones, the joints cannot be spaced less than 5’ (1.5 m) apart and no more than 7’-6” (2.3 m).

Joints should be 1 ¼” (32 mm) deep on all edges of the parapet, stopping 1’-1” (330 mm) above the bridge deck. Saw cuts should be performed while the concrete is still green, as long as the concrete will not be damaged.

If GFRP is being used, then once the parapet has cured a saw cut of 4” (102 mm) must be performed. Contractors may also choose to do a full depth saw cut, but must stop 1’-1” (330 mm) above the bridge deck. A profile view of the GFRP saw cut perimeter can be seen in Figure 5.

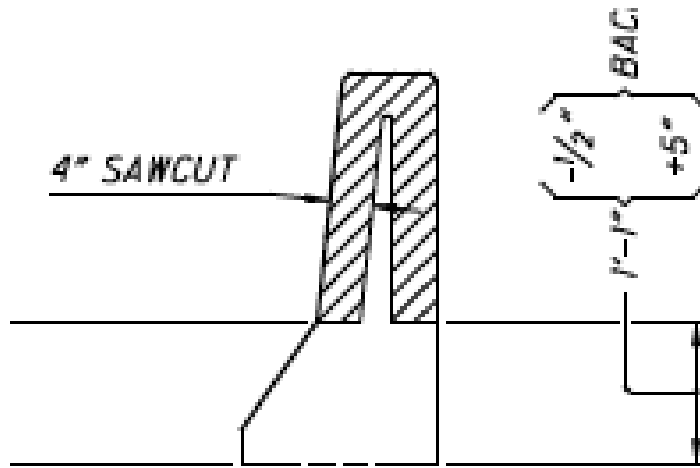

Figure 5: GFRP Saw Cut Perimeter Profile (ODOT, 2013)

3.3 Concrete Mix

It is specified by ODOT that concrete provided by contractors for bridge parapets should meet requirements of Class QC2 concrete. This class of concrete must have a compressive strength of 4,500 psi (31 MPa), must contain 520 lbs/yd³ (310 kg/m³) of cement, have a slump of 1-4” (406 mm), and an air content of 6 ± 2 percent.

As of the 2013 ODOT Specification book, slip forming will now be an approved method of construction. If a contractor decides to use slip forming as their preferred construction method, all “honeycombing, cracking, tearing, and other defects” must be repaired immediately (ODOT, 2013). It is also specified that repairing all defects should be done with concrete and no use of water. After 21 days, if an engineer inspection identifies horizontal cracking, it must be repaired through the use of epoxy injection.

3.4 Construction Procedures

There are various construction procedures to be followed before, during and after the pouring the concrete for a bridge parapet. For parapets that are cast-in-place, it is important that the inside of the wood forms be sprayed with oil before the concrete is placed. Once the concrete is placed the top of the parapet must be smoothed and kept moist by the spraying a mist of water on the concrete.

Once the forms are removed it is especially important to keep the concrete moist. If there is a significant period of time between the removal of the forms and the placement of wet burlap, a water mist must be constantly applied to the parapet to keep the concrete from becoming drying. Also during this time, if there are any pockets or honeycombs in the face of the parapet they should be rubbed out, so that there is a flat surface.

Then, to ensure that the parapet is kept moist throughout the curing process, a soaker water hose with holes punctured throughout its length is placed on top of the parapet allowing water to freely wet the concrete. Wet burlap is then placed over the hose, covering the whole wall and a clear plastic tarp is placed over the burlap and firmly held in place. The curing process should last a total of seven days, unless otherwise specified.

For parapets that are constructed using slip forming, some of the construction procedures vary. As soon as the parapet comes out of the slip forming machine, any necessary repairs must be performed. Once repairs are performed, it is again important to keep the concrete moist. The same measures may be taken to ensure the concrete does not dry. Additionally, the same curing time frame should be followed.

CHAPTER IV

OTHER DEPARTMENT OF TRANSPORTATION PRACTICES

Fourteen state DOTs' bridge parapet specifications were reviewed in addition to ODOT. After review of these specifications, various differences from ODOT practices were identified. Of the fourteen other DOTs, four of them did not differ from ODOT's specifications significantly.

4.1 Virginia Department of Transportation

The Virginia Department of Transportation (VDOT) specifies that bridge parapets are to be 2'-8" (813 mm) tall. They will have a bottom width of 16 7/16" (418 mm) and a top width of 9 1/4" (235 mm). There will be a total of eight pieces of horizontal #4 (13 mm) rebar used, which is a total cross-sectional area of 1.6 in² (1032 mm²). The horizontal rebar will be continuous in 20' (6 m) spans of rebar (VDOT, 2008).

The parapet will also be constructed of vertical #5 (16 mm) rebar that will bend over the horizontal rebar. The vertical rebar will be spaced every 12" (305 mm). All

reinforcement should be reinforcing steel grade 60. There should be a minimum 2" (51 mm) of concrete cover on the flat face of the parapet, as seen in Figure 6 (VDOT, 2008).

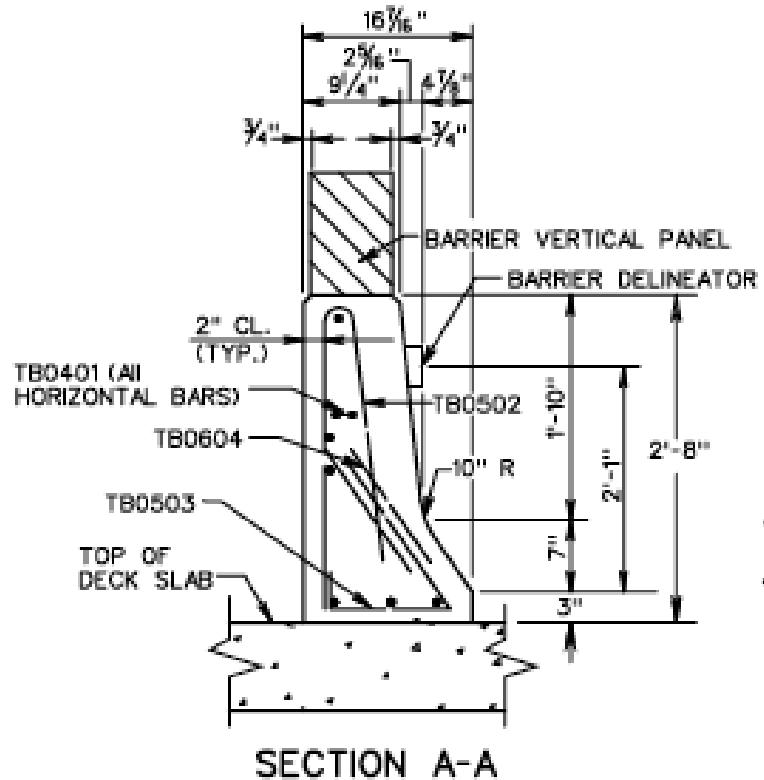

Figure 6: Virginia Department of Transportation Parapet Profile (VDOT, 2008)

4.1.1 Construction Joints

A construction joint should be located above each pier, and the others are equally spaced throughout the remaining length of the parapet. The remaining construction joints must be spaced no less than 6' (1.8 m) apart and no more than 12' (3.7 m) apart (VDOT, 2008).

4.1.2 Concrete Mixture

Virginia specifies that contractors must provide concrete that meets the requirements of Class A4 concrete. Class A4 concrete must have a 28-day compressive strength of 4000 psi (28 MPa). It must also contain a minimum of 635 lbs/yd³ (375 kg/m³) of concrete, 2-4" (51-102 mm) slump, and an air content of $6 \frac{1}{2} \pm 1 \frac{1}{2}$ percent (VDOT, 2008).

Slip forming is an allowed method of parapet construction in Virginia. If the contractor is going to slip form, the slump may then be less than 2" (51 mm), but the air content can be no less than 4 percent and aggregate cannot be less than number 7 (22 mm) (VDOT, 2013).

4.2 Maryland Department of Transportation

Maryland Department of Transportation equivalent bridge parapets are 3'-6" (1.1 m) tall, with a bottom and top width of 1'-6 1/4" (464 mm) and 10" (254 mm), respectively. See figure 7. Four horizontal pieces of #7 (22 mm) rebar are toward the top of the parapet, and four horizontal pieces of #8 (25 mm) rebar are used toward the bottom of the parapet, which is a total cross-sectional area of 5.56 in² (3,587 mm²). The horizontal rebar is to be continuous from expansion opening to expansion opening (Maryland DOT, 2012)

Vertical #5 (16 mm) rebar that bends over all the horizontal rebar is also required and placed at a maximum of 8" (200 mm). Additional vertical #5 (16 mm) rebar is required at the bottom of the parapet, bending over the bottom two pieces of horizontal rebar and extends into the deck slab. This rebar is also placed at a maximum of every 8" (200 mm) and is offset from the other set of vertical rebar by 4" (100 mm). There is two inches (50

mm) of cover on the vertical rebar. The profile view of Maryland's bridge parapet can be seen in Figure 7 (Maryland DOT, 2012).

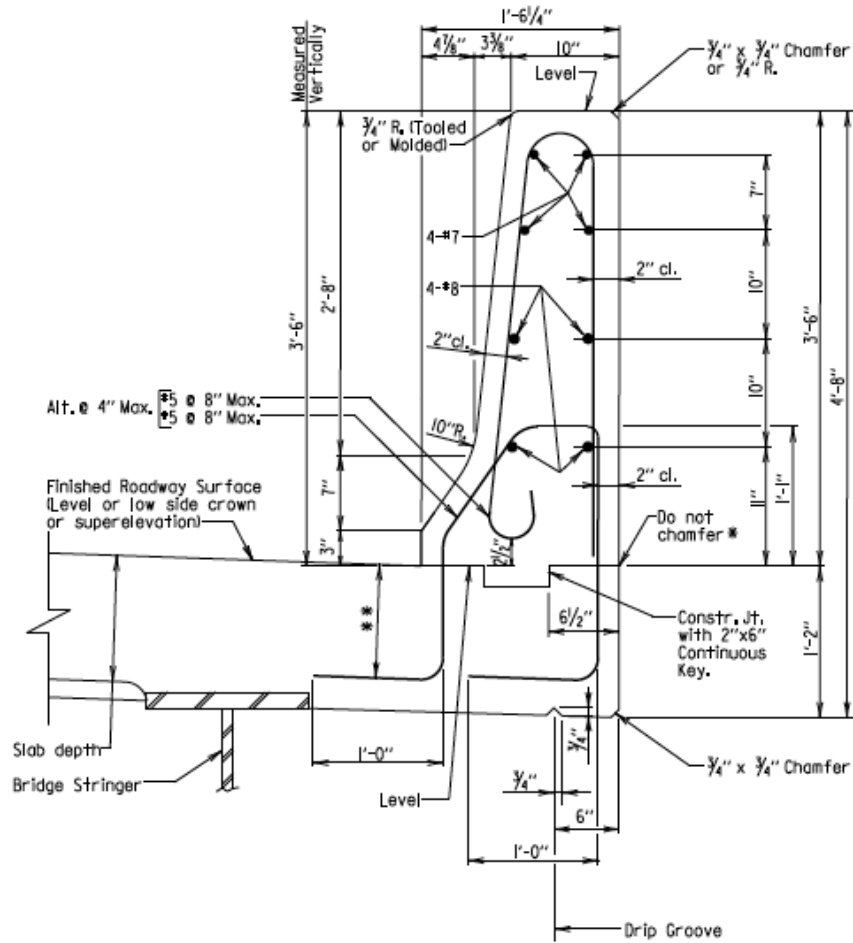

Figure 7: Maryland Department of Transportation Parapet Profile (Maryland DOT, 2012)

4.2.1 Construction Joints

Construction joints are to be spaced 20' (6.1 m) apart. Also, joints are to be placed at the center of each railing panel when railing is used. Joints are to be cut 1/2" (13 mm) deep and 1/8" (3 mm) thick, as seen in Figure 8.

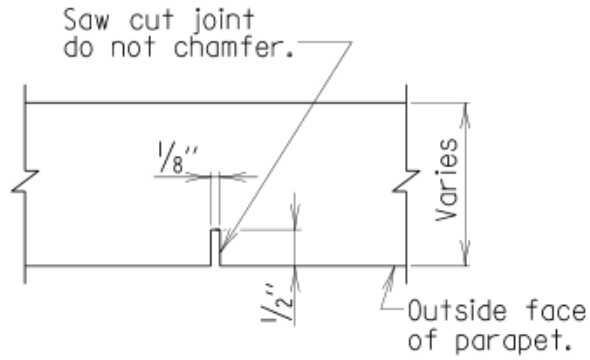

Figure 8: Maryland DOT Joint Cut Depth (Maryland DOT, 2012)

The saw cut control joint should be sawed the same day concrete is poured. The joint should be cut all the way around the parapet, including both front and back faces. An example of the saw cut joint length can be seen in Figure 9 (Maryland DOT, 2012).

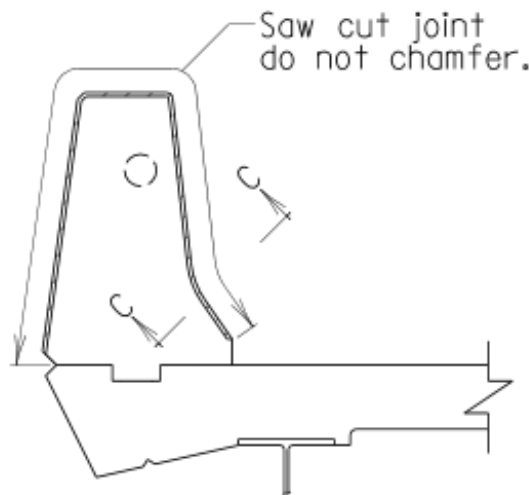

Figure 9: Maryland DOT Saw Cut Length (Maryland DOT, 2012)

4.2.2 Concrete Mixture

Maryland specifies that contractors must use their concrete mix number 6 when constructing bridge parapets. This mix specifies a 28-day compressive strength of 4,500 psi (31 MPa). The slip form construction method is allowed (Maryland DOT, 2012).

4.3 Michigan Department of Transportation

The Michigan Department of Transportation specifies that bridge parapets are to be 2'-10" (864 mm) tall. The bottom of the parapet is 1'-5" (432 mm) and tapers to a width of 8" (203 mm) at the top. Five horizontal pieces of #5 (16 mm) rebar are required, which is a total cross-sectional area of 1.55 in² (1,000 mm²). The horizontal pieces require 3" (76 mm) of cover from the edges, and a minimum lap length of 1'-4" (406 mm) to ensure the reinforcing steel is continuous (Michigan DOT, 2013).

The parapet design also specifies that #4 (13 mm) vertical rebar is required to bend around the horizontal rebar. This vertical rebar can be spaced at a maximum of 8" (200 mm). Another piece of vertical rebar is required at the bottom of the parapet, and must extend into the bridge deck a minimum of 6" (152 mm). The profile view of Michigan's bridge parapet can be seen in Figure 10 (Michigan DOT, 2013).

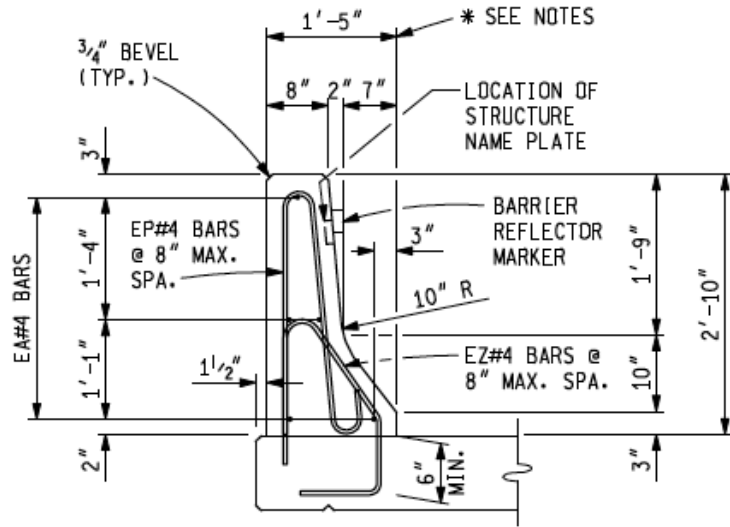

SECTION A-A

Figure 10: Michigan Department of Transportation Parapet Profile (Michigan DOT, 2013)

4.3.1 Construction Joints

The Michigan Department of Transportation specifies that construction joints are to be cut to a depth of $\frac{3}{4}$ " (19 mm) and they are also to be beveled. The joints are to be spaced at a minimum of 10' (3 m) and a maximum of 20' (6 m) intervals. (Michigan DOT, 2013).

4.4 Missouri Department of Transportation

The Missouri Department of Transportation (MODOT) specifies that the bridge parapet heights can vary, but must be taller than 2'-6" (762 mm). The bottom of the parapet is 1' -4" (400 mm) and tapers to a top width of 7" (178 mm). Inside the parapet, there are seven horizontal pieces of #5 (16 mm) rebar, which is a total cross-sectional

rebar area of 2.17 in^2 (1400 mm^2). This rebar must be lapped a minimum of $2' - 11''$ (889 mm), so that they run through the entire length of the parapet (MODOT, 2012).

Additionally, there is vertical rebar that bends over the horizontal rebar and extends into the bridge deck. The vertical rebar are also sized #5 (16 mm), and should be spaced at $12''$ (305 mm) and must have $1 \frac{1}{2}''$ (38 mm) of cover. The profile view of Missouri's bridge parapet can be seen in Figure 11 (MODOT, 2012).

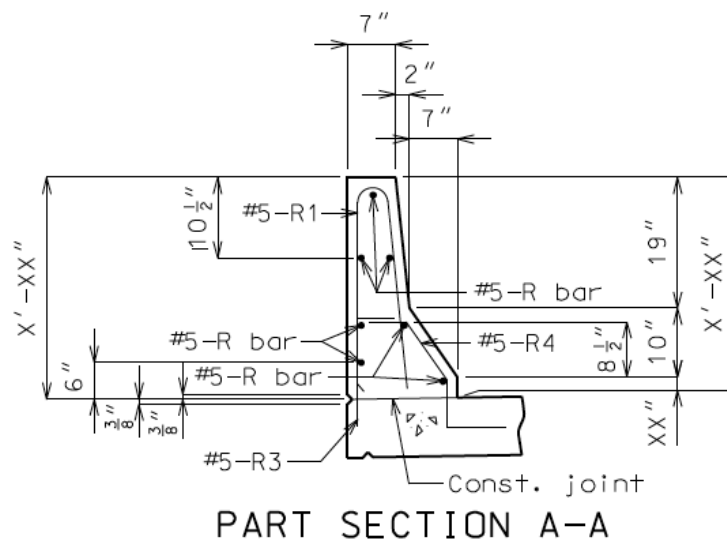

Figure 11: Missouri Department of Transportation Parapet Profile (MODOT, 2012)

4.4.1 Construction Joints

Construction joints are used for parapets throughout Missouri. A joint must be placed above each pier, and an additional joint will be placed on each side of the pier. These additional joints will be spaced $10'$ (3 m) from the pier. Construction joints are cut all the way through the parapet and stop $3''$ (76 mm) above the deck of the bridge. It is also noted that a $\frac{1}{4}''$ (6 mm) joint filler must also be used, as seen below (MODOT, 2012).

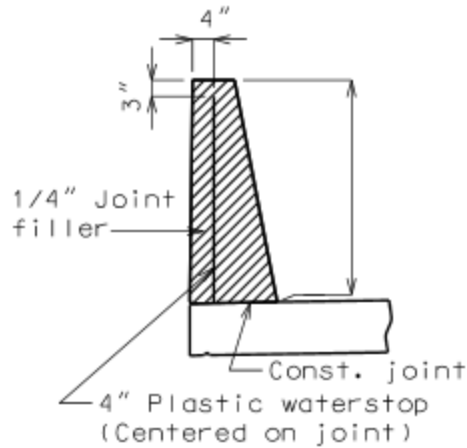

Figure 12: MODOT Construction Joint (MODOT, 2012)

4.4.2 Concrete Mixture

There is no standard concrete mixture provided by the Missouri Department of Transportation. Contractors can use any concrete mixture as long as it meets the requirements of Class B-1 concrete. This class of concrete must meet a 28-day compressive strength of 4000 psi (28 Mpa). Also, it can have a maximum slump of 4" (100 mm), and contain 640 lbs/ft³ (380 kg/m³) of cement (MODOT, 2012).

Slip forming is also allowed, and according to Dennis Hackman, a state bridge engineer for MODOT, slip forming is used 98 percent of the time for parapet construction (Dennis Heckman, personal communication, February 10, 2014).

4.5 Montana Department of Transportation

The Montana Department of Transportation (MDT) specifies that bridge parapets must be 2' -8" (813 mm) tall. The bottom of the parapet has a width of 1' -6" (457 mm) and tappers to a top width of 6" (152 mm). The parapet includes seven horizontal pieces of #4 (13 mm) rebar, with an additional two horizontal pieces of #5 (16 mm) rebar

toward the middle of the parapet This amounts to a total cross-sectional rebar area of 2.02 in² (1303 mm²) (MDT, 2012).

The parapet also requires vertical #4 (13 mm) rebar that bends over the horizontal rebar, and an additional piece of vertical #4 (13 mm) rebar that follows the sloped face of the parapet and extends into the bridge deck. A 1 1/2" (38 mm) amount of cover is required for the vertical rebar, and these pieces are spaced at 12" (305 mm). The profile view of Montana's bridge parapet can be seen in Figure 13 (MDT, 2012).

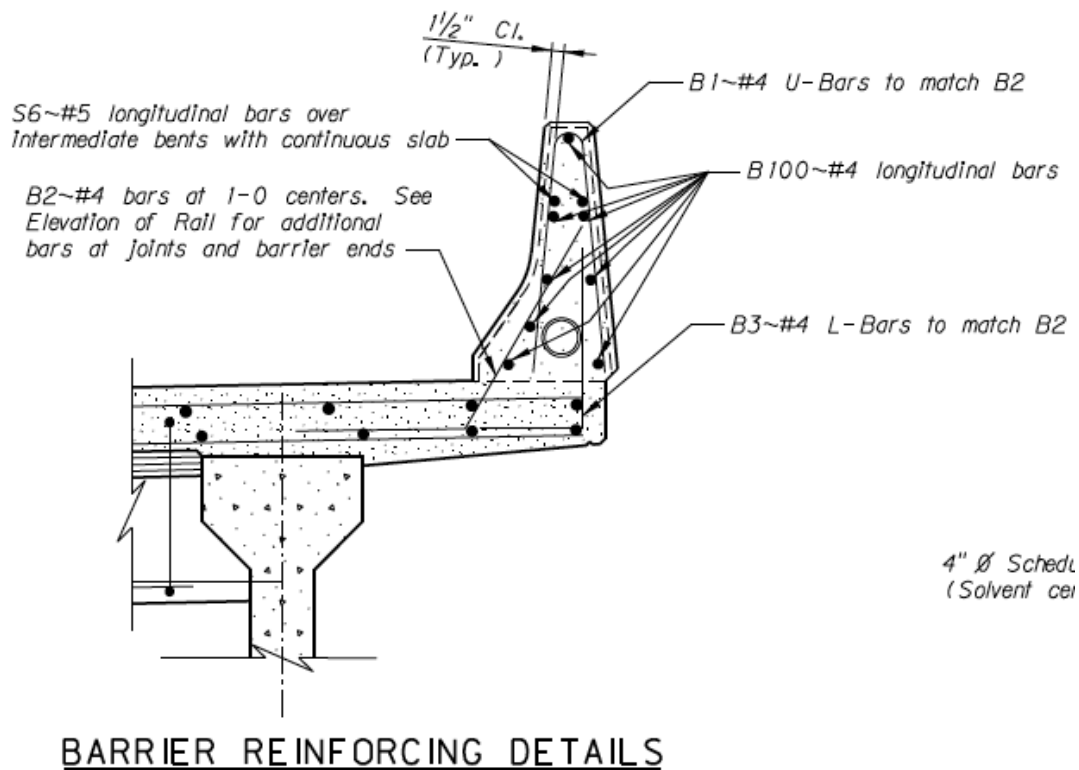

Figure 13: Montana Department of Transportation Parapet Profile (MDT, 2012)

4.5.1 Construction Joints

Construction joints are not cut into parapets in Montana (MDT, 2012).

4.5.2 Concrete Mixture

Montana requires that concrete must meet Class SD concrete specifications. Class SD concrete must have a minimum 28-day compressive strength of 4,000 psi (28 MPa). Also, it must contain 520-580 lbs/ft³ (310-345 kg/m³) of cement, have a 1 ½ - 2" (38-51 mm) of slump, and have 5-7 percent air content.

Slip forming is allowed for parapets in Montana (MDT, 2012).

4.6 Oklahoma Department of Transportation

Oklahoma Department of Transportation (OKDOT) bridge parapets should vary from 2' – 5" (237 mm) to 2' – 10" (864 mm) tall. They should have a bottom width of 1' – 4" (406 mm) that slopes to a top width of 7" (178 mm). The parapets are horizontally reinforced with either six or ten pieces of #4 (13 mm) rebar, which is a total cross-sectional rebar area of 1.2 in² (774 mm²) or 2 in² (1290 mm²), respectively (OKDOT, 2005).

They are reinforced with vertical #5 (16 mm) rebar the bends over the top of the horizontal rebar. Also, they have additional #5 vertical rebar the bends below the horizontal rebar and extends into the bridge deck. The vertical rebar has a 1.5" (38 mm) cover on both vertical and sloped faces of the parapet, and is spaced at 12" (305 mm) on center. The profile view of Oklahoma's bridge parapet can be seen in Figure 14 (OKDOT, 2005).

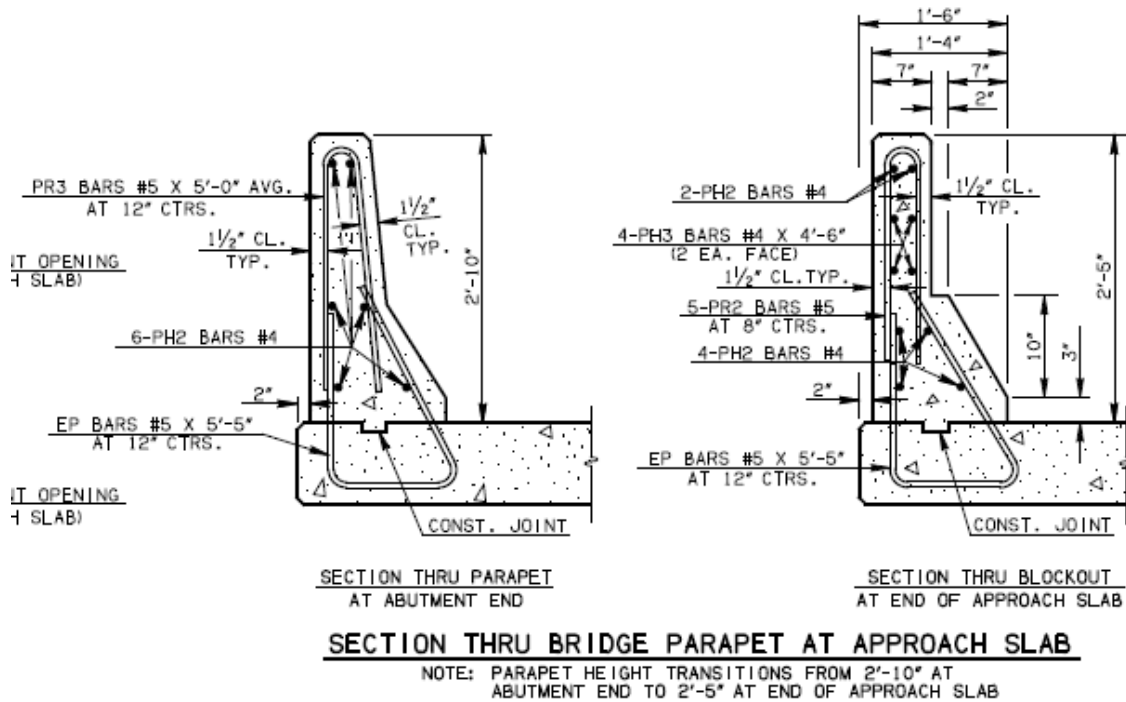

Figure 14: Oklahoma Department of Transportation Parapet Profile (OKDOT, 2005)

4.6.1 Construction Joints

Construction joints consist of a 1/4" (6 mm) thick preformed expansion material. Crack control joints should have 3/4" (19 mm) chamfers or be 3/4" (19 mm) deep saw cut. If the parapet has drain openings, then the crack control joint must be placed in the center of the 5' (1.5 m) solid parapet between drain openings. If there are no drain openings, then the crack control joint must be placed at 10' (3 m) spacing. The layout of crack control joints can be seen in Figure 15 (OKDOT, 2005).

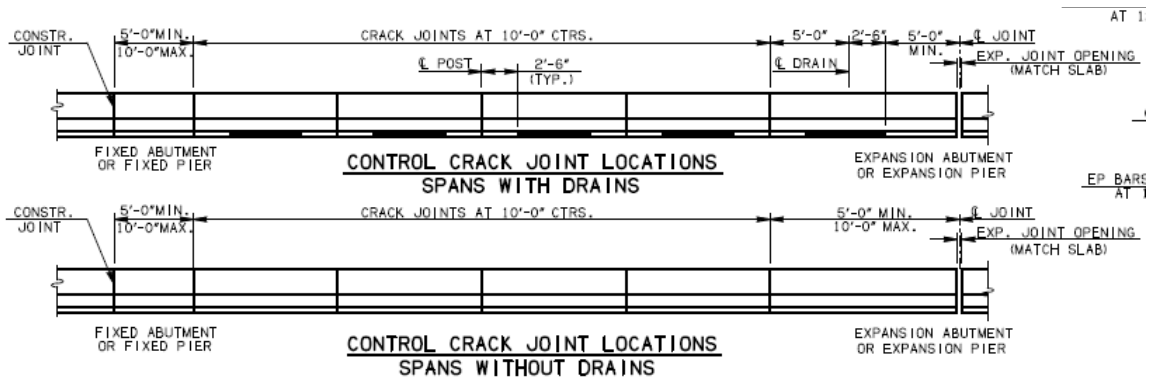

Figure 15: Oklahoma Department of Transportation Control Joints (OKDOT, 2005)

4.6.2 Concrete Mixture

There is no standard concrete mixture required by Oklahoma Department of Transportation. Instead, contractors must provide a concrete mixture that meets the requirements of Class AA concrete. Class AA concrete must have a minimum 28-day compressive strength of 4,000 psi (28 MPa). It must also contain a minimum of 564 lbs/ft³ (335 kg/m³) of concrete, contain 6.5±1.5 percent air content, and have a slump of 2±1" (25-76 mm) (OKDOT, 2005).

Contractors may use slip forming.

4.7 Idaho Department of Transportation

The Idaho Department of Transportation (IDT) specifies that bridge parapets must be 2' – 8" (813 mm) tall, and have a bottom width of 1' – 4" (406 mm) sloped to a top width of 8" (203 mm). The parapet is reinforced with seven horizontal pieces of #5 (16 mm) rebar, which is a total cross-sectional rebar area of 2.17 in² (1400 mm²) (ITD, 2010).

The parapets are reinforced with #5 (16 mm) vertical rebar that is bent over the top of the horizontal rebar. There is 1" (25 mm) of minimum cover on both the vertical and

sloped sides. The vertical rebar is spaced at 10 5/8" (270 mm). The profile view of Idaho's bridge parapet can be seen in Figure 16 (ITD, 2010).

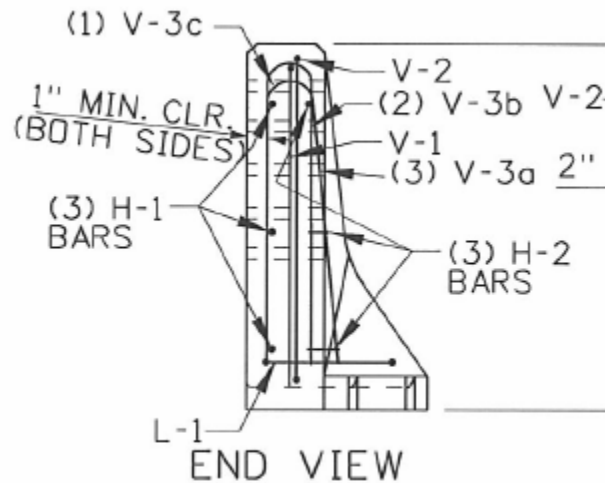

Figure 16: Idaho Department of Transportation Parapet Profile (ITD, 2010)

4.7.1 Construction Joints

Construction joints are placed above each pier, and then spaced evenly throughout the remaining length of the parapet. The construction joints can be spaced no less than 6' (1.8 m) and no more than 12' (3.7 m) apart. The joints will be 3/4" (19 mm) deep and chamfered. The construction joint, referred to as a dummy joint, can be seen in Figure 17 (ITD, 2010).

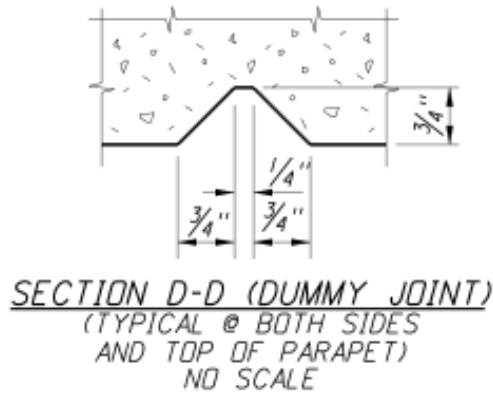

Figure 17: IDT Dummy Joint (IDT, 2010)

4.7.2 Concrete Mixture

Idaho Department of Transportation specified that contractors must provide concrete that meets the requirements of Class 40AF concrete. Class 40AF concrete must have a minimum 28-day compressive strength of 4,000 psi (28 MPa). Also, it must contain a minimum of 560 lbs/ft³ (330 kg/m³) of cement, and have 1-6 percent air content. Contractors are not allowed to use slip forming when constructing parapets (ITD, 2010).

4.8 Alabama Department of Transportation

The Alabama Department of Transportation (ALDOT) specifies that the parapet is 2' – 8" (813 mm) tall. The bottom and top widths of the parapet are 1' – 4.5" (419 mm) and 6" (152 mm), respectively. The parapet shall include seven pieces of #5 (16 mm) horizontal rebar, which is a total cross-sectional rebar area of 2.17 in² (1400 mm²) (ALDOT, 2008).

There is also vertical rebar along the vertical face with 2" (51 mm) of cover, and another piece of straight rebar along the sloped face that also has 2" (51 mm) of cover. Another piece of rebar is spliced with the vertical rebar that bends into the bridge deck.

All vertical rebar is spaced at 10" (254 mm) on center. All steel shall be specified on shop drawings. The profile view of Alabama's bridge parapet can be seen in Figure 18 (ALDOT, 2008).

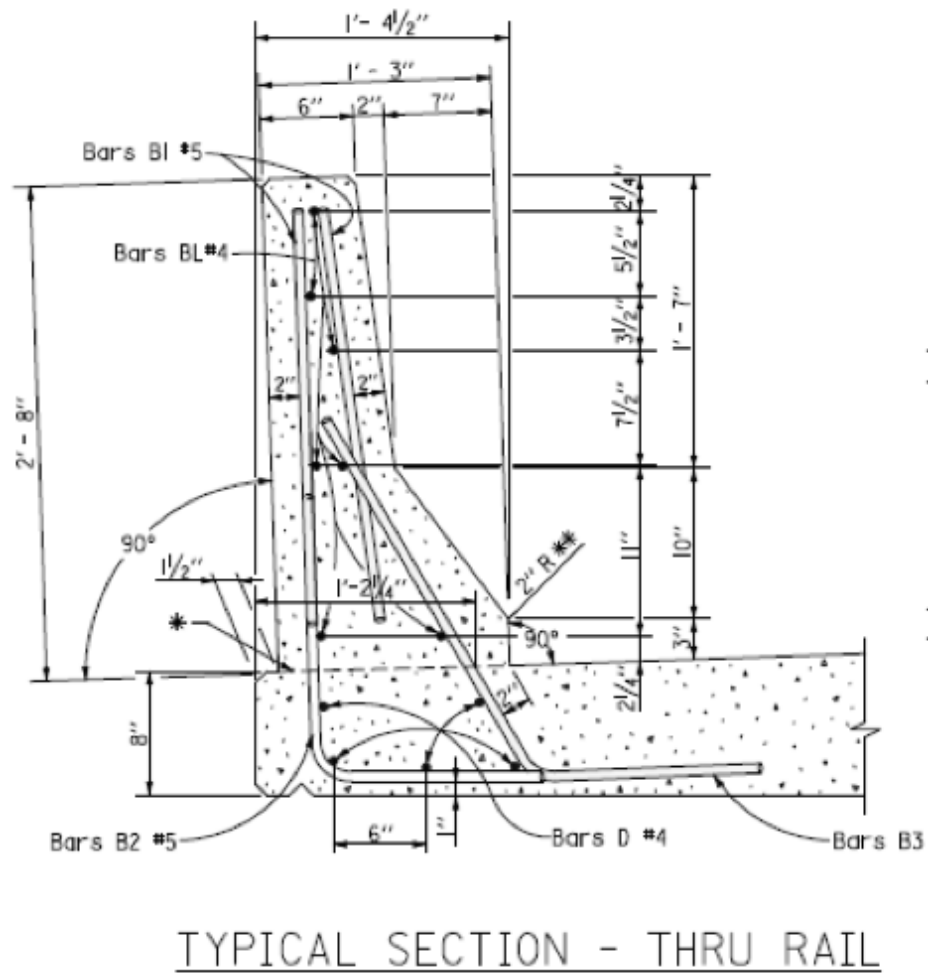

Figure 18: Alabama Department of Transportation Parapet Profile (ALDOT, 2008)

4.8.1 Construction Joints

The Alabama Department of Transportation specifies that construction joints are cut at a spacing of every 20' (6 m). The joints should also be cut to a depth of 1 1/2" (38 mm).

An example of the construction joint on a different type of ALDOT concrete barrier can be seen in Figure 19 (ALDOT, 2008).

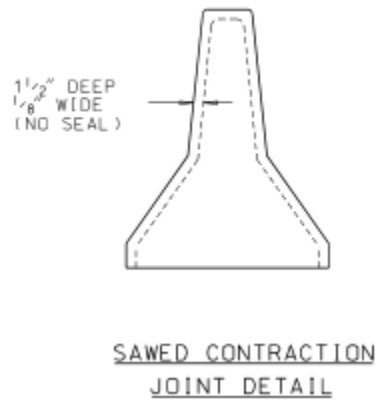

Figure 19: ALDOT Construction Joint (ALDOT, 2008)

4.9 California Department of Transportation

The California Department of Transportation (Caltrans) specifies that bridge parapets must be 2' – 8" (813 mm) tall. The bottom width will vary depending on the project drawings, but will slope to a top width of 1' (305 mm). The parapet will be reinforced with thirteen horizontal pieces of #5 rebar, which is a total cross-sectional rebar area of 4.03 in^2 ($2,600 \text{ mm}^2$) (Caltrans, 2010).

The parapet will also be reinforced with vertical #5 (16 mm) rebar on both faces, and another piece of #5 (16 mm) rebar that will be bent over the top of the horizontal rebar. There will be 1" (25 mm) cover except when noted otherwise. The vertical rebar will be spaced at 8" (203 mm) on center. The profile view of California's bridge parapet can be seen in Figure 20 (Caltrans, 2010).

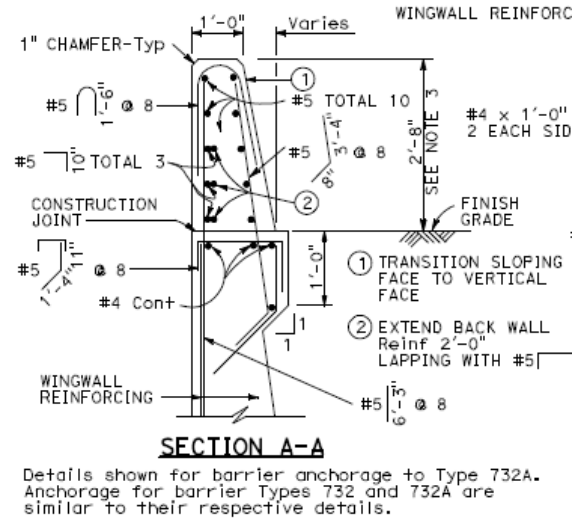

Figure 20: California Department of Transportation Parapet Profile (Caltrans, 2010)

4.10 Minnesota Department of Transportation

Minnesota Department of Transportation (MNDOT) bridge parapets are 2' – 10" (864 mm) tall with a base width of 1' – 6" (457 mm) and taper to a top width of 10.5" (267 mm). Eight pieces of #5 (16 mm) horizontal rebar will be used along with vertical rebar that bends around the horizontal rebar. The horizontal rebar adds to a total cross-sectional area of 2.48 in² (1600 mm²) (MNDOT, 2006).

The vertical rebar are spaced every 8" (203 mm). There are 2.25" (57 mm) of cover on the vertical face of the parapet and a minimum of 2" (51 mm) cover on the sloped face. The strength of concrete and rebar used are determined from project drawings. The profile view of Minnesota's bridge parapet can be seen in Figure 21 (MNDOT, 2006).

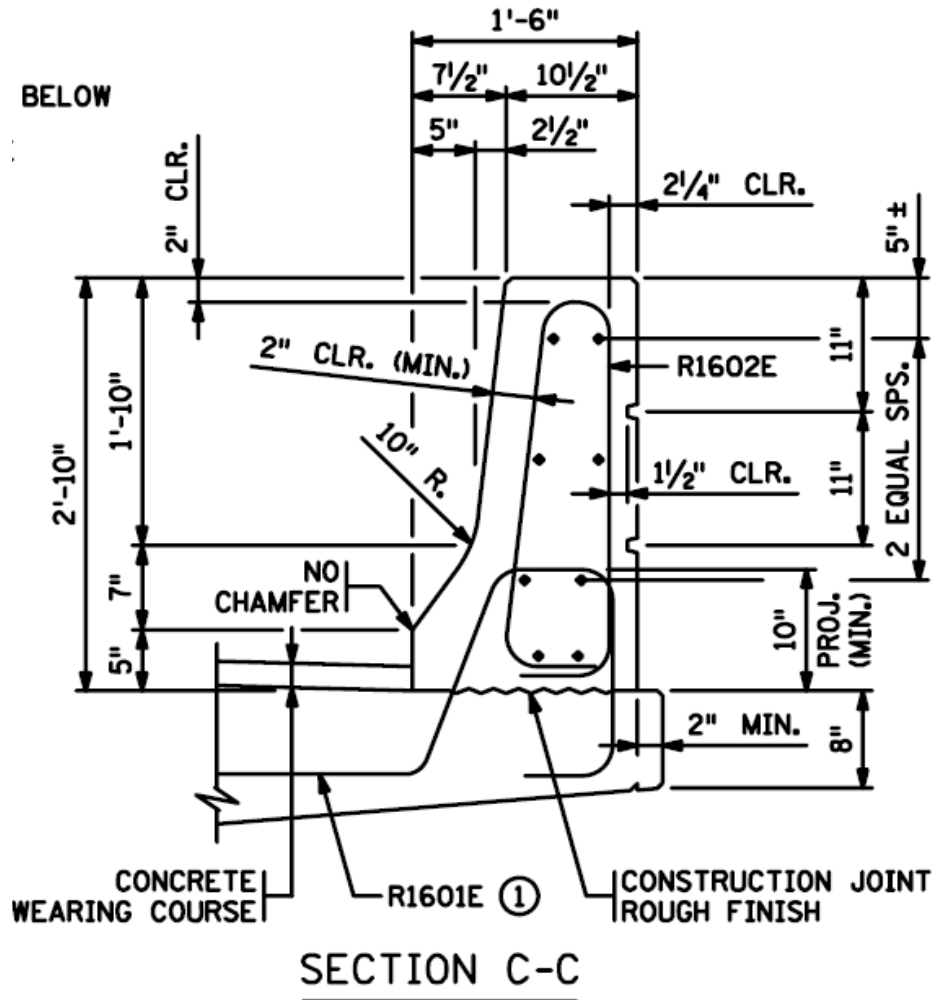

Figure 21: Minnesota Department of Transportation Parapet Profile (MNDOT, 2006)

4.10.1 Construction Joints

Construction joints are spaced evenly throughout the parapet, and can be spaced no more than 20' (6 m) apart. These joints are to be formed in the shape of a V and shall be placed at the time the parapet is poured. The joints should meet a minimum depth of 3" (76 mm) (MNDOT, 2006).

4.10.2 Concrete Mixture

Minnesota specifies that the concrete used for parapets must be Class 3Y46. This concrete must meet a 28-day compressive strength of 4,000 psi (28 MPa). It can also have a slump of 3-4" (76-102 mm), 640 lbs/ft³ (380 kg/m²), and has a maximum aggregate size of 1 1/2" (38 mm). Slip forming is an approved method of construction in Minnesota (MNDOT, 2006).

CHAPTER V
REPAIR PROJECTS

One of the largest problems that premature bridge parapet cracking causes is the cost to replace them before the deck of the bridge needs to be replaced and traffic disruption. If many early extensive parapet cracks occur, then the parapets must either be replaced or patched before the bridge deck has seen its lifespan worth of wear. Repair projects were identified in districts 1, 3, 8, and 12. A map of their locations can be seen in Figure 22.

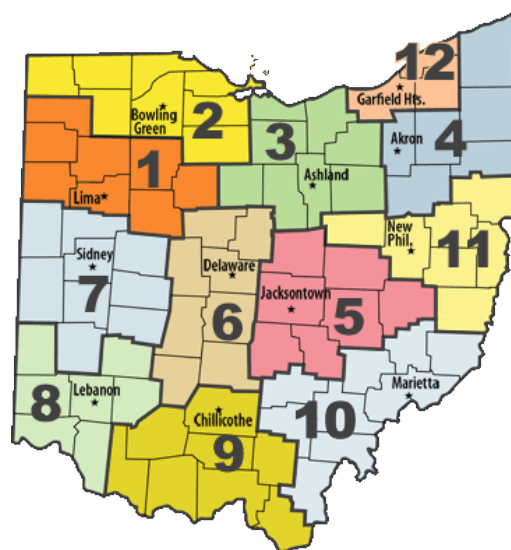

Figure 22: ODOT District Map (ODOT)

5.1 ODOT District 1

ODOT District 1, located in the northwest portion of the state, has identified four specific projects in which parapets have been replaced, or need to be replaced in the near future.

5.1.1 Bridge Number VAN-30-2041

This bridge is an overpass crossing US30, located in Van Wert County. The bridge was originally built in 1987 and had a total length of 462 feet (140 m). In 2009, the right side parapet of the bridge had extensive cracking that required the parapet to be replaced. The approximate total cost endured of replacing the parapet and deck edge was \$150,000, which is \$325 per linear foot of parapet (\$1,070/m).

5.1.2 Bridge Number ALL-75-1836

This bridge, located in Allen County, will need to have its parapets replaced. The bridge was originally built in 1965 and has a total length of 310 feet (94 m). It is estimated that this work will need to be done within the next five to ten years.

Although it is not considered premature, the replacement of the parapets will need to be done before the bridge deck needs to be repaired. An official estimate for this work has not yet been calculated, but Rod Maas, PE in District 1 has a rough estimate of \$225,000 (Rod Maas, personal communication, March 4, 2014). This is roughly \$363 per linear foot of parapet (\$1,190/m). A photograph of the cracking seen in this parapet can be seen in Figure 23.



Figure 23: Bridge Number ALL-75-1836 Cracking (Photo Provided by Rod Maas)

5.1.3 Bridge Number ALL-696-0086

This bridge is located in Allen County, and will need to have its parapets replaced. The bridge was originally built eight years ago in 2006, and has a total length of 175 feet (53 m). It is estimated that the parapets will need to be replaced within the next five to ten years.

An official estimate for the work needed has not yet been calculated, but Rod Maas, PE in District 1 has a rough estimate of \$150,000 (Rod Maas, personal communication, March 4, 2014). This is roughly \$428 per linear foot of parapet (\$1,400/m). A photograph of the cracking seen on this parapet can be seen in Figure 24.



Figure 24: Bridge Number ALL-696-0086 Cracking (Photo Provided by Rod Maas)

5.1.4 Bridge Number ALL-65-1322

This bridge is an overpass located in Allen County. It was originally built in 1969 and has a total length of 295 feet (90 m). Patches were done to the parapets and vandal protection fencing (VPF) was installed in 2009. The total cost of this work was \$599,417 for the whole structure. The approximate cost per linear foot of parapet is \$175 (\$574/m).

Since 2009, the parapets have begun to deteriorate again and will need more patching done. The patch work is planned for the spring construction season of 2014. A photograph of the parapet can be seen in Figure 25.



Figure 25: Bridge Number ALL-65-1322 Cracking (Photo Provided by Steve Reichenbach)

5.2 ODOT District 3

ODOT District 3, located in the central, northern part of Ohio, has identified one specific project in which a parapet has been repaired.

5.2.1 PID 81374

The bridge was originally built in 1995 and a total of approximately 1200 feet (366 m) of parapet was repaired. The total cost of the repairs to the parapet was \$176,228, which is \$147 per linear foot of parapet (\$480/m).

5.3 ODOT District 8

ODOT District 8, located in the southwest corner of Ohio, was able to identify five specific projects in which parapets have been either repaired or replaced.

5.3.1 Bridge Number GRE-675-0895

This bridge parapet repair occurred in Greene County in 2012. The bridge is an overpass on Grange Hall Road that passes over I-675 and has a total length of 260 feet (79 m). Due to large cracks and damage caused by vandal protection fencing (VPF), the upper foot and a half of the parapet on both sides of the bridges needed to be repaired. The parapet damages can be seen in Figure 26.

The total cost of repairs to the two parapets was \$218,852. This cost included the repair of the transition sections and purchase and installation of new VPF. The cost is approximately \$420 per linear foot of parapet (\$1,380/m).



Figure 26: Bridge Number GRE-675-0895 Cracking (Photo Provided by Brandon Collett, PE)

5.3.2 Bridge Number HAM-74-1116L

This bridge parapet repair occurred in Hamilton County in 2013. The bridge is on I-74 and passes over Harrison Ave with a total length of 282 feet (86 m). Selected sections along one of the parapets needed to be replaced due to concrete deterioration. A photograph of the deterioration can be seen in Figure 27.

The top foot and a half of the selected sections needed to be repaired. Other work that was performed at the same time included barrier replacement and zone painting. The total cost of these repairs was \$17,000, which is \$60 per linear foot of parapet (\$200/m).



Figure 27: Bridge Number HAM-74-1116L Cracking (Photo Provided by Brandon Collett, PE)

5.3.3 Bridge Number GRE-675-1034

This bridge repair occurred in Greene County. The bridge is an overpass on North Fairfield Road that crosses over I-675 and has a total length of 277 feet (84 m). Due to extensive concrete deterioration and cracking caused by VPF, multiple patches were needed along the length of the parapet. A photograph of the deterioration can be seen in Figure 28. The total cost of these patches was \$13,600, which is \$50 per linear foot of parapet (\$910/m).



Figure 28: Bridge Number GRE-675-1034 Cracking (Photo Provided by Brandon Collett, PE)

5.3.4 Bridge Number GRE-42-0789

This bridge parapet repair occurred in Greene County and has a total length of 244 feet (74 m). The cost of repairs included in this project included the removal of loose concrete from the parapets, various deep patches, and applying an epoxy sealer. A photograph of the cracking and repairs being done can be seen in Figure 29. The total cost of these patches was \$117,000, which is \$240 per linear foot of parapet (\$790/m).



Figure 29: Bridge Number GRE-42-0789 (Photo Provided by Brandon Collett, PE)

5.3.5 Bridge Number GRE-380-0671

This bridge parapet repair will occur in Greene County with a total length of 277 feet (84 m). The repairs needed for this bridge not only include the replacement of the parapet, but also an overlay of the bridge deck and possible replacement of the VPF. A photograph of the cracking can be seen in Figure 30. The estimated total cost of these repairs is \$200,000, which is \$361 per linear foot of parapet (\$1180/m).



Figure 30: Bridge Number GRE-380-0671 Cracking (Photo Provided by Brandon Collett, PE)

5.4 ODOT District 12

ODOT District 12, located in northeast Ohio, has identified two specific projects in which parapets have been replaced in 2013.

5.4.1 Bridge Number CUY-71-0000

This bridge parapet replacement occurred in 2013, in Cuyahoga County. Both sides of the 618 feet (188 m) long bridge parapet needed to be replaced. Costs for the replacement of the parapet include \$120,000 for the removal of existing parapet, \$30,000 for new reinforcing steel, \$35,000 for dowel bars, \$34,000 for concrete, \$10,000 to seal the

parapets, and \$40,000 for the purchase and installation of six foot tall VRP. The total cost of replacement for this bridge was \$269,000, which is \$435 per linear foot of parapet (\$1,425/m).

5.4.2 Bridge Number CUY-17-0449

The parapets for this bridge, also located in Cuyahoga County, were replaced in 2013. This bridge was a total length of 309 feet (94 m). There were also many costs endured for the replacement of this bridge, including \$65,000 for removal of the existing parapets, \$9,000 for new reinforcing steel, \$2,000 for dowel bars, \$17,000 for concrete, \$8,000 to seal the parapets, and \$21,000 for the purchase and installation of the six foot tall VPF. The total cost of replacement for the bridge was \$122,000, which is \$395 per linear foot of parapet (\$1,295/m).

5.5 California DOT

The California Department of Transportation, known as Caltrans, has identified three specific projects in which parapets have been replaced in 2010.

5.5.1 Rancheria Creek Bridge

The Rancheria Creek Bridge crosses over the Rancheria Creek, located in Fresno County. This bridge was originally built in 1977, and has a total length of 229 feet (70 m). The total cost to repair both sides of the bridge's parapets due to freeze thaw damage was \$149,900, which is \$327 per linear foot of parapet (\$1,070/m).

5.5.2 Big Creek Bridge

The Big Creek Bridge crosses over Big Creek, and is also located in Fresno County. This bridge was originally built in 1977, and has a total length of 151 feet (46 m). The total cost to replace both sides of the bridge's parapets due to freeze thaw damage was \$98,600, which is \$326 per linear foot of parapet (\$1,070/m).

5.5.3 Tamarack Creek Bridge

The Tamarack Creek Bridge crosses over the Tamarack Creek in Fresno County. This bridge was originally built less than ten years ago in 2006. This bridge has a total length of 166 feet (51 m). The total cost to replace both sides of the bridge's parapet due to freeze thaw damage was \$109,600. This amounts to \$330 per linear foot of parapet (\$1,080/m).

CHAPTER VI

ANALYSIS

Other state DOTs with bridge parapet designs and specifications different than those of ODOT were surveyed to analyze their effectiveness.

6.1 Comparison of DOT Practices

A total of fourteen additional state DOTs bridge parapet specifications were reviewed, in addition to ODOT. Of the fourteen other DOTs, four of them did not differ from ODOTs specifications significantly. The ten remaining state DOT bridge parapet specifications were then reviewed to identify differences from ODOT specification. The three main differences found between these other state DOTs and ODOT's specifications are the amount of cover required, the amount of horizontal rebar required, and the spacing of deflection joins.

6.1.1 Concrete Cover

First, the amount of cover for vertical and horizontal rebar, as stated by the ODOT specification is a minimum of 2" (51 mm). From the other DOTs reviewed, five of them

require a different amount of cover. Idaho and California only require 1" (25 mm) of cover, while Montana, Oklahoma, and Missouri 1 ½" (38 mm) of cover. Michigan, however, requires the greatest amount of cover, which is 3" (76 mm).

6.1.2 Horizontal Rebar

ODOT and many other state DOTs use #5 (16 mm) rebar for their horizontal bars. Maryland's DOT specifies that eight pieces of horizontal rebar are to be used, but the top four pieces are to be #7 (22 mm) rebar and the bottom four pieces are to be #8 (25 mm) rebar. This is a much larger amount of steel in the parapet than ODOT uses. Also, Virginia, Oklahoma, and Alabama use less steel than Ohio. They require that #4 (13 mm) bars are used.

The amount of horizontal rebar used also varies between many of the state DOTs. ODOT parapet designs specify that eight pieces of continuous #5 (16 mm) rebar is to be used, which is a total cross-sectional area of 1.99 in^2 ($1,285 \text{ mm}^2$). The DOTs for Idaho and Missouri specify in the parapet designs that seven continuous pieces of #5 (16 mm) rebar are to be used, which is a total cross-sectional area of 2.17 in^2 ($1,400 \text{ mm}^2$) for both DOTs. Alabama's DOT also specifies seven continuous pieces, but it is placed in a zig-zag type pattern within the parapet. Michigan and Virginia's state DOTs requires the least amount of rebar. Michigan only specifies five continuous pieces for total cross-sectional area of 1.55 in^2 ($1,000 \text{ mm}^2$), and Virginia specifies eight continuous pieces for a total cross-sectional area of 1.6 in^2 ($1,030 \text{ mm}^2$). Finally, Oklahoma's state DOT specifies that six or ten continuous pieces of rebar are to be used for a total cross-sectional area of $1.2 - 2 \text{ in}^2$ ($775 - 1290 \text{ mm}^2$).

There are also a few DOTs that require more rebar than specified by ODOT. The DOT for Montana specifies ten pieces. Although Montana specifies ten pieces, its total cross-sectional area is only slightly larger at 2.02 in² (1,300 mm²). Finally, Minnesota specifies that eight continuous pieces of rebar should be used for a total cross-sectional area of 2.48 in².

The state DOTs that require the most horizontal rebar are California and Maryland. Thirteen pieces of rebar are used in parapets in California. Five pieces are placed along the sloped side of the parapet and an additional five down the straight side, but the bottom three horizontal bars down the straight side are doubled. This creates a total cross-sectional area of 4.03 in² (2,600 mm²). Maryland specifies that four continuous pieces of #7 (22 mm) rebar and four continuous pieces of #8 (25 mm) rebar should be used for a total cross-sectional area of 5.56 in² (3,590 mm²).

6.1.3 Vertical Spacing

Finally, vertical rebar spacing is also varied among the state DOTs. ODOT, along with Virginia, Missouri, Montana, and Oklahoma, all use a vertical spacing of 12" (305 mm). Idaho and Alabama slightly decrease their vertical rebar spacing to 10" (254 mm), and Maryland, Michigan, California, and Minnesota all have the smallest vertical spacing of 8" (203 mm). A table comparing all of the different specifications can be seen below in Table I.

State DOT	Number of Horizontal Rebar	Horizontal Rebar Size (mm)	Horizontal Rebar Area (in ² / mm ²)	Vertical Rebar Size (mm)	Vertical Rebar Spacing (inches / mm)	Rebar Cover (inches / mm)
Ohio	7	#5-#6 (16- 19)	1.99 / 1285	#5 (16)	12 / 305	2 ½ / 64
Virginia	8	#4 (13)	1.6 / 1030	#5 (16)	12 / 305	2 / 51
Maryland	8	#7-#8 (22- 25)	5.56 / 3590	#5 (16)	8 / 203	2 / 51
Michigan	5	#5 (16)	1.55 / 1000	#4 (13)	8 / 203	3 / 76
Missouri	7	#5 (16)	2.17 / 1400	#5 (16)	12 / 305	1 ½ / 38
Montana	10	#4-#5 (13- 16)	2.02 / 1300	#4 (13)	12 / 305	1 ½ / 38
Oklahoma	6-10	#4 (13)	1.2-2 / 775-1290	#5 (16)	12 / 305	1 ½ / 38
Idaho	7	#5 (16)	2.17 / 1400	#5 (16)	10 / 254	1 / 25
Alabama	7	#4 (13)	2.17 / 1400	#5 (16)	10 / 254	2 / 51

California	13	#5 (16)	4.03 / 2600	#5 (16)	8 / 203	1 / 25
Minnesota	8	-	2.48 / 1600	-	8 / 203	2 / 51

Table I: Current State DOT Parapet Practices

6.2 Construction Joint Comparison

Only a few of the DOTs that were contacted were able to provide information about the construction joints. Of those whom provided information regarding joint spacing, only a few provided a minimum joint spacing length. ODOT had the smallest minimum joint spacing at five feet (1.5 m). Virginia, Michigan, and Idaho were the only three other states to provide a minimum joint spacing, which was six (1.8 m), ten (3 m), and six feet (1.8 m), respectively.

The maximum joint spacing varied greatly within the DOTs. Missouri and Oklahoma had the smallest, maximum joint spacing of ten feet (3 m). Next, Virginia and Idaho had a maximum joint spacing of twelve feet (3.7 m). Ohio was alone with a maximum joint spacing of fifteen feet (4.5 m). Finally, Maryland, Michigan, Alabama, and Minnesota had the largest maximum joint spacing of twenty feet (6 m).

6.2.1 Joint Depth

In addition to ODOT, only three other state DOTs provided information on how deep the cut is required to be. ODOT uses a 1 ¼” (32 mm) deep cut all the way around the parapet. Missouri cuts all the way through their parapets stopping about 3” (76 mm) above the deck of the bridge. Minnesota uses a 3” (76 mm) deep cut all the way around

their parapets, and Alabama uses a 1 ½” (38 mm) deep cut all the way around the parapet. Finally, Maryland, Michigan and Oklahoma use the smallest cut depths of ½” (13 mm), ¾” (19 mm), and ¾” (19 mm), respectively. All the information provided by state DOTs on construction joints can be seen below in Table II.

DOT	Minimum Spacing (feet / m)	Maximum Spacing (feet / m)	Depth (inches / mm)
Ohio	5 / 1.5	15 / 4.6	1 ¼ / 32
Virginia	6 / 1.8	12 / 3.7	-
Maryland	-	20 / 6.1	½ / 13
Michigan	10 / 3	20 / 6.1	¾ / 19
Missouri	-	10 / 3	Through
Oklahoma	-	10 / 3	¾ / 19
Idaho	6 / 1.8	12 / 3.7	-
Alabama	-	20 / 6.1	1 ½ / 38
Minnesota	-	20 / 6.1	3 / 76

Table II: State DOT Joint Spacing

6.3 Concrete Mixture Comparison

All of the state DOTs have different designations for the class of concrete used in the construction of bridge parapets. Many of the concrete classes share similar characteristics. All of the classes of concrete, except for Ohio’s and Maryland’s, require a

28-day compressive strength of 4000 psi (28 MPa). The Ohio and Maryland state DOTs require a slightly higher 28-day compressive strength of 4500 psi (31 MPa).

The allowable concrete slumps are also all very similar. The slump had a range of 1 - 4 inches (25-102 mm) for most state DOTs, except for Montana and Oklahoma who all a maximum slump for 2 - 3 inches (51-76 mm), respectively.

One characteristic of the concrete used for each state that can vary greatly is the minimum cement content. The amount of cement required per cubic yard of concrete ranges from 520 to 640 pounds (310-380 kg/m³). Ohio and Montana state DOTs require the least amount of cement at 520 pounds per cubic yard (310 kg/m³), while Missouri and Minnesota require the most amount of cement at 640 pound per cubic yard (380 kg/m³).

Another characteristic of the concrete classes that is similar among them all is the allowable air content. For the states that provided the air content, the range was typically between four and eight percent. The exception to this is Idaho, who allows air content to range between zero and six percent.

Finally, all of the state DOTs surveyed allow slip forming to be used for the construction of their bridge parapets. If slip forming is the chosen construction method, then some of the characteristics can change slightly. For example, the allowable slump may be more often closer to one inch. A table depicting all of the concrete class characteristics for each state can be seen below in Table III.

DOT	Concrete Class	Compressive Strength (psi / MPa)	Cement Content (lb/yd ³ / kg/m ³)	Slump (inches / mm)	Air Content (percent)	Slip Forming
Ohio	QC2	4,500 / 31	520 / 310	1-4 / 25-100	6 ± 2	Yes
Virginia	A4	4,000 / 28	635 / 375	2-4 / 50-100	6.5 ± 1.5	Yes
Maryland	Mix #6	4,500 / 31	-	-	-	Yes
Missouri	B-1	4,000 / 28	640 / 380	1-4 / 25-100	-	Yes
Montana	SD	4,000 / 28	520-580 / 310-345	1 ½ -2 / 38-50	5-7	Yes
Oklahoma	AA	4,000 / 28	564 / 335	2 ± 1 / 25-75	6.5 ± 1.5	Yes
Idaho	40AF	4,000 / 28	560 / 330	-	0-6	Yes
Minnesota	3Y46	4,000 / 28	640 / 380	3-4 / 75-100	-	Yes

Table III: State DOT Concrete Mixes

6.4 State DOT Parapet Performance

After analyzing the differences in the state DOT's specifications, it was then important to ask the state DOTs about their parapet's performance. Most of the state DOTs

surveyed replied, reporting whether or not bridge parapet cracking was a problem for their state. Of the ten other state DOTs that were surveyed only three did not reply, including Maryland, Alabama, and Minnesota Departments of Transportation.

6.4.1 States with Poor Parapet Performance

Of the seven state DOTs that did reply, four of them confirmed that bridge parapet cracking was a problem for their state. First, from the Virginia Department of Transportation, Fawaz Saraf, P.E. replied that there are problems with bridge parapet cracking in Virginia and was also able to provide supportive information on a project that was conducted (Fawaz Saraf, P.E., personal communication, February 2, 2014). More of the parapet information on the I-95 Express Lanes research project can be found in the literature review.

From the Michigan Department of Transportation, Matthew Chynoweth, P.E. was able to reply that parapet cracking is also a problem there (Matthew Chynoweth, personal communication, February 7, 2014). Additionally, Mr. Chynoweth provided two separate research reports in which Michigan has conducted their own research on parapet performance and the causes of cracking. More information on the two research reports can be found in the literature review.

Next, from the California Department of Transportation, Michael Lee replied that parapet cracking can be a problem in his state, and mainly attributes this problem to freeze thaw complications (Michael Lee, personal communication, March 6, 2014). Mr. Lee was also able to provide information on three recent parapet replacement projects that took place.

The last state DOT that was able to confirm that bridge parapet cracking is a problem in their state was Oklahoma. Although no other information could be provided, Mr. Walter Peters P.E. did agree parapet cracking was a problem (Walter Peters, personal communication, February 11, 2014).

6.4.2 States with Adequate Parapet Performance

The three remaining state DOTs, Missouri, Montana, and Idaho, all state that parapet cracking is not a problem for their states. According to Dennis Heckman, an engineer for the Missouri Department of Transportation, there are a few isolated incidences of shrinkage cracking, but nothing that is widespread throughout Missouri (Dennis Heckman, personal communication, February 10, 2014).

From the Montana Department of Transportation, Mr. Kent Barnes confirms that there is some parapet cracking seen in Montana, but nothing that warrants any concern (Kent Barnes, personal communication, February 11, 2014).

Finally, Mr. Mike Ebright from the Idaho Department of Transportation reports that cracking is not a big concern there either. Mr. Ebright also stated that any cracking seen in Idaho is more of a cosmetic concern than a structural issue (Mike Ebright, personal communication, February 7, 2014).

A few of the bridge parapet characteristics for these three states are different from ODOT's. To start, Missouri only allows a maximum joint spacing of ten feet (3 m), whereas ODOT allows up to fifteen feet (4.5 m). Also, Missouri requires that joint cuts are made through the whole parapet, and ODOT only specifies a 1 ¼" (32 mm) deep cut.

Montana DOT requires that more horizontal rebar be used for their parapets. ODOT only requires seven pieces of horizontal rebar, but Montana requires three more pieces, making a total of ten pieces. This adds an additional 0.93 in² (600 mm²) of horizontal steel to the parapet.

Idaho DOT spaces their vertical rebar every 10” (254 mm), while ODOT spaces their rebar every 12” (305 mm). Idaho also only allows a maximum joint spacing of twelve feet (3.7 m), whereas ODOT allows up to fifteen feet (4.5 m).

Finally, the three of the state DOTs that do not have a parapet cracking problem have concrete characteristics that differ greatly. The three states only require a 28-day compressive strength of 4,000 psi (28 MPa). ODOT requires a higher 28-day compressive strength of 4,500 psi (31 MPa). Also, all three require a larger amount of cement per cubic foot of concrete. While ODOT only requires 520 pounds per cubic yard of cement (310 kg/m³), Missouri, Montana, and Idaho require 640 (380 kg/m³), 520-580 (310-345 kg/m³), and 560 (330 kg/m³) per cubic yard of cement.

6.5 ODOT Cost Analysis

Of the twelve districts within ODOT, four of them provided information on bridge parapet repair or replacement projects. District 1 provided information on four separate bridge parapet projects. The total costs of these projects ranged from \$150,000 to \$599,417, and the cost per linear foot of parapet ranged from \$175 to \$428 (\$53-\$130 per meter). Based on the four example projects provided, District 1 spends on average a total of \$281,104 per parapet replacement project, or \$323 per linear foot of parapet (\$98 per meter).

District 3 was only able to provide information about one bridge parapet repair project. The total cost for this project was \$176,228, for a cost of \$147 per linear foot (\$482 per meter). Based on the one example project provided, District 3 spends on average \$176,288 per parapet replacement project, or \$147 per linear foot of parapet (\$482 per meter).

District 8 was also able to provide a total of five bridge parapet repair or replacement projects. The total costs for these projects ranged from \$13,600 to \$218,852. The cost per linear foot of parapet for these projects ranged from \$50 to \$420 (\$165-\$1380 per meter). Based on the five example projects provided, District 8 spends on average \$113,290 per parapet replacement project, or \$226 per linear foot of parapet (\$740 per meter).

District 12 was able to provide information on two bridge parapet repair or replacement projects. The total costs for these projects were \$122,000 and \$269,000. The cost per linear foot of parapet for these projects was \$395 and \$435 (\$1295-\$1435 per meter). Based on the two example projects provided, District 12 spends on average \$195,500 per parapet replacement project, or \$415 per linear foot of parapet (\$1360 per meter). Seen below, Table IV provides information on the cost for each bridge parapet project.

Based on the twelve bridge parapet repair or replacement projects provided by the four different districts, it can be seen that ODOT as a whole spends on average \$188,175 per parapet replacement project, or \$283 per linear foot of parapet (\$925 per meter). This average cost, however, can vary greatly depending on the location, length, severity of the parapet damage, and extent of the repairs.

District	Bridge	Total Cost	Average Total Cost	Cost per Linear Foot of Parapet / Per Meter	Average Cost Per Linear Foot / Per Meter
District 1	VAN-30-2041	\$150,000	\$281,104	\$325 / \$1065	\$323 / \$1060
	ALL-75-1836	\$225,000		\$363 / \$1190	
	ALL-696-0086	\$150,000		\$428 / \$1400	
	ALL-65-1322	\$599,417		\$175 / \$575	
District 3	PID 81374	\$176,228	\$176,228	\$147 / \$480	\$147 / \$480
District 8	HAM-74-1116L	\$17,000	\$113,290	\$60 / \$200	\$226 / \$740
	GRE-675-1034	\$13,600		\$50 / \$165	
	GRE-675-0895	\$218,852		\$420 / \$1375	
	GRE-42-0789	\$117,000		\$240 / \$785	
	GRE-380-0671	\$200,000		\$361 / \$1185	
District 12	CUY-71-0000	\$269,000	\$195,500	\$435 / \$1425	\$415 / \$1360
	CUY-17-0449	\$122,000		\$395 / \$1295	

Table IV: ODOT Bridge Parapet Repair Project Costs

6.6 Caltrans Cost Analysis

Of all the other state DOTs that were surveyed, only the California Department of Transportation was able to provide information on bridge parapet replacement projects.

Caltrans provided information on three different bridge parapet projects. The total cost for these projects ranged from \$98,600 to \$149,900. The cost per linear foot of parapet ranged from \$326 to \$330 (\$1080 per meter). Based on the three example projects provided, Caltrans spends on average \$119,367 per parapet repair project, or \$328 per linear foot of parapet (\$1075 per meter).

This average cost per linear foot is significantly more than ODOT’s average cost of \$283 per linear foot (\$920 per meter). This is most likely because of the added steel California uses in their parapet design. Table V provides the cost information for the three bridge parapet projects.

Bridge Name	Total Cost	Average Total Cost	Cost Per Linear Foot / Per Meter	Average Cost Per Linear Foot / Per Meter
Rancheria Creek	\$149,900	\$119,367	\$327 / \$1070	\$328 / \$1075
Big Creek	\$98,600		\$326 / \$1070	
Tamarack Creek	\$109,600		\$330 / \$1080	

Table V: Caltrans Bridge Parapet Repair Project Costs

CHAPTER VII

CONCLUSIONS

Based on the analysis of ODOT's and other state DOT's bridge parapet designs and specifications, a few main conclusions can be developed.

7.1 Design Practice Conclusion

Based on the information received from ODOT, the currently performed practices are not reducing the amount of cracks seen in bridge parapets. Other state DOTs have similar bridge parapet design characteristics and are also seeing widespread parapet cracking. A few of the state DOTs, however, do not have the widespread cracking problem.

The three state DOTs that are not subject to widespread parapet cracking include Missouri, Montana and Idaho. These three state DOTs each have bridge parapet practices that are different from ODOT's. The most important different practices that are seen, are the construction joint spacing, and the saw cut depth.

7.1.1 Construction Joint Spacing

Currently ODOT specifies that in areas where there is no negative moment the construction joint spacing can be spaced a maximum of 15' (4.5 m) apart. To save time, especially on longer bridges, most contractors will space their joints at the maximum of 15' (4.5 m). This requires fewer saw cuts, therefore saving the contractor a small amount of time.

Missouri and Idaho state DOTs specify that construction joint spacing can only be spaced a maximum of 10' (3 m) and 12' (3.7 m) apart, respectively. Although this small difference may not seem significant, on a 200' (60 m) long parapet it could potentially increase the number of construction joints by three to seven joints. As the length of the bridge increases, the number of additional construction joints may also increase. This increase in joints allows the parapet to crack in designated areas rather than in between joints. Additionally, this small increase in the number of joints cut will not cost the contractor much more time than is already needed.

7.1.2 Construction Joint Cut Depth

Currently ODOT specifies that construction joint cuts are to be 1 ¼" (32 mm) deep all the way around the parapet. The depth of this cut, however, may not be deep enough to encourage the concrete to crack in these areas. The cross-sectional area of the parapet is only slightly reduced.

The Missouri DOT specifies that construction joints are to be cut all the way through the parapet and epoxy coated rebar, only stopping about 3" (76 mm) above the bridge deck. By cutting the parapet all the way through, it is no longer considered continuous, but

is a series of shorter segments. Creating shorter segments will reduce the fatigue seen by a continuous parapet, but on the other hand the parapet loses its structural redundancy.

The parapet will no longer act like an additional beam for the bridge.

7.1.3 Cement Content

Currently ODOT specifies that the cement content be 520 lbs/ft³ (8330 kg/m³) of concrete. Among the other state DOTs surveyed this cement content was among the lowest. All three states, Missouri, Montana, and Idaho specify larger amounts of cement. This could make for stronger parapets that resist cracking better, as long as the water to cement ratio isn't too high. As the water to cement ratio increases, the concrete becomes easier to place, but reduce strength (ACI 224R-07, 2007).

CHAPTER VIII

RECOMMENDATIONS

There are a couple bridge parapet design recommendations that ODOT could consider implementing.

8.1 Maximum Construction Joint Spacing

The first recommendation is to reduce the maximum allowable construction joint spacing. The current 15' (4.6 m) maximum spacing should be reduced to 10' (3 m). By increasing the number of construction joints, the possibility of cracking between joints is reduced. According to ACI Committee 224R, "if not provided with adequate joints to accommodate shrinkage, the concrete will make its own joints by cracking" (p.4).

8.2 Construction Joint Depth

The second recommendation is to increase the construction joint cut depth. The parapet should still maintain its continuous structural redundancy, but the total cross-sectional area should be reduced. The current 1 ¼" (32 mm) joint cut depth should be

increased so that it is always 4” (102 mm). This could potentially allow enough of a decrease in cross-sectional area to encourage the concrete to crack in these designated areas.

Due to the increase in construction joint cut depth, ODOT could also consider specifying the use of GFRP bar in place of reinforcing steel. The amount of concrete cover required on the face of the parapet is only 2 ½” (64 mm). This means that a 4” (102 mm) deep saw cut would cut through the reinforcing steel, potentially exposing its ends to become corrosive. The use of GFRP bar could help to eliminate the possibility of corrosion seen within the parapet. If GFRP bar cannot be used, then a joint sealant should be applied to reduce the corrosion in the steel reinforcement.

8.3 Other Recommendations

It is also recommended that the parapet be cured for a long enough period of time. By curing the parapet for at least seven days, it reduced the changes of shrinkage cracking. “Procedures should ensure the presence of adequate moisture to sustain hydration in the surface concrete during the early ages of strength development,” (p.6, ACI 224R-01, 2001). Likewise, during the curing process the parapet should see constant moisture.

Finally, it is recommended that once the formwork is removed, the parapet surface should be finished immediately. Properly rubbing the parapet wall can reduce cracks, and pits seen, which also reduces the possibility of unwanted moisture and chlorides entering the concrete, (ACI 224R-07, 2007).

8.4 Final Improved Bridge Parapet Design Recommendation

Parapets must be 3' (1 m) tall with a bottom width of 1'-6" (455 mm) and a top width of 8 ½" (215 mm). A total of seven horizontal pieces of rebar should be used, with the very top bar a #6 (19 mm), and the remaining six pieced be #5 (16 mm) rebar.

The vertical rebar should also be #5 (16 mm) in size and be spaced evenly twelve inches apart throughout the length of the parapet. Concrete cover on all faces of the parapet should be at least 2 ½" (64 mm) deep.

The construction joint spacing in negative moment zones should remain no less than 5' (1.5 m) apart and no more than 7'-6" (2.3 m) apart. In areas where the moment is positive, however, the maximum joint spacing should be 10' (3 m). Construction joint depth should also always be 4" (102 mm) deep. GFRP bar or a joint sealant should be used to stop corrosion of the reinforcement.

Finally, the ODOT concrete class QC2 should still have a 28-day compressive strength of 4,500 psi (31 MPa), an allowable slump of 1-4" (25-102 mm), and an air content of 6 ± 2 percent. The cement content should now be 580 lbs/yd³ (340 kg/m³).

8.5 Expected Benefits of Recommendation Implementation

The benefits that are expected to be seen by implementing these recommendations are that the amount and severity of premature bridge parapet cracking will reduce not only in Northeast Ohio, but throughout all of the ODOT districts. The amount of premature cracking will reduce so that it is only seen in isolated incidences, like those of Missouri, Montana, and Idaho.

This will also reduce the amount of premature bridge parapet repair and replacement projects that ODOT must conduct. The average cost endured by ODOT is \$188,175 per parapet replacement project, or \$283 per linear foot (\$920 per meter) of parapet. If the amount of premature bridge parapet repair and replacement projects is reduced, then ODOT is able to potentially save hundreds of thousands of dollar per year.

REFERENCES

- ACI Committee 224. (2007). "ACI 224.1R-07 Causes, Evaluation, and Repair of Cracks in Concrete Structures". *Farmington Hills: American Concrete Institute.*
- ACI Committee 224. (2001). "ACI 224R-01 Control of Cracking of Concrete Structures". *Farmington Hills: American Concrete Institute.*
- ACI Committee 224. (1995). "ACI 224.3R-95 Joints in Concrete Construction". *Farmington Hills: American Concrete Institute.*
- ACI Committee 224. (2013). "ACI 224.4R-13 Guide to Design Detailing to Mitigate Cracking". *Farmington Hills: American Concrete Institution.*
- ACI Committee 231. (2010). "ACI 231R-10 Report on Early Age Cracking: Causes, Measurement, and Mitigation. *Farmington Hills: American Concrete Institution.*
- ALDOT. (2008). Bridge Standards. Alabama Department of Transportation. [http://www.dot.state.al.us/brweb/doc/Standards/I-131%20\(Sheet%203%20of%208\).pdf](http://www.dot.state.al.us/brweb/doc/Standards/I-131%20(Sheet%203%20of%208).pdf)
- Battaglia, I., Whited, G., & Swank, R. (2008). "Eclipse Shrinkage Reducing Admixture Product Evaluation". *Wisconsin Department of Transportation.*
- Caltrans. (2010). Project Plans. California Department of Transportation. http://www.dot.ca.gov/hq/esc/oe/project_plans/highway_plans/stdplans_US-customary-units_10/viewable_pdf/2010-Std-Plns-for-Web.pdf
- ITD. (2010). Standard Drawings. Boise: Idaho Transportation Department. http://www.itd.idaho.gov/design/StandardDrawings/English/G2C_1010.pdf
- Maryland DOT. (2012). Bridge Standards. Maryland Department of Transportation. http://apps.roads.maryland.gov/BusinessWithSHA/bizStdsSpecs/obd/BridgeStandards/Bridge_Stds_sheets.asp?PlotID=2852&PlotDirectory=09_Super-Concrete-Work2852.
- Michigan DOT (2013). Standard Plan Book. Lansing: Michigan Department of Transportation. http://www.michigan.gov/documents/mdot/MDOT_2012_May_Monthly_Update_386619_7.pdf.
- Mindess, S., Young, J. F., & Darwin, D. (2003). "Concrete". *Prentice Hall*. Upper Saddle River, NJ, 505-513.

MNDOT (2006). Bridge Manual. St. Paul: Minnesota Department of Transportation. <http://www.dot.state.mn.us/bridge/manuals/LRFD/pdf/section13.pdf>

MDT. (2012). Bridge Standard Drawings. Helena: Montana Department of Transportation. https://www.mdt.mt.gov/business/contracting/bridge/cad_files.shtml.

ODOT. (2013). Bridge Standard Drawings. Columbus: Ohio Department of Transportation. <http://www.dot.state.oh.us/Divisions/Engineering/Structures/standard/Bridges/Pages/StandardBridgeDrawings.aspx>.

OKDOT. (2005). Bridge Standards. Oklahoma Department of Transportation. http://www.okladot.state.ok.us/bridge/1999-sb-lrfd/brd_std_1999-sb-lrfd-002.pdf

PCA. (2011). "Design and Control of Concrete Mixtures: The Guide to Applications, Methods, and Materials". *Portland Cement Association*.

Saraf, F. K. P.E. (2013). "I-95 Express Lanes Project". *Virginia Department of Transportation*.

Staton, John F. & Knauff, Jason. (2007). "Performance of Michigan's Concrete Barriers". *Michigan Transportation Commission*.

Van Dam, T., Delem, L., Peterson, K. R., & Sutter, L. L. (2004). "Causes and Cures for Cracking of Concrete Barriers". *Transportation Materials Research Center*.

VDOT. (2008). Road and Bridge Standards. Virginia Department of Transportation. http://www.virginiadot.org/business/locdes/2008_standards_complete_sections.asp

Wight, J. K. & MacGregor, J. G. (2012). "Reinforced Concrete Mechanics and Design". *Prentice Hall*. Upper Saddle River, NJ, 96-97.